

Erosion Prevention and Sediment Control Manual



February 2024

City of Albany
Public Works Department
333 Broadalbin Street
PO Box 490
Albany, OR 97321-0144
Phone: (541) 917-7676
Fax: (541) 917-7573
www.cityofalbany.net

Chapter 1 INTRODUCTION AND BACKGROUND

1.1	Introduction.....	1
1.1.1	The Manual.....	1
1.1.2	Goal Statement.....	1
1.1.3	Disclaimer.....	1
1.1.4	Common Acronyms.....	2
1.2	Background and Policies.....	2
1.2.1	Total Maximum Daily Loads.....	2
1.2.2	NPDES Program for Municipal Separate Storm Sewer Systems (MS4).....	3
1.2.2	City Municipal Code Title 12.....	3
1.2.4	1200-C Series Permits.....	3
1.3	The Erosion and Sedimentation Processes.....	4
	• Soil Erodibility.....	4
	• Vegetative Cover.....	4
	• Topography.....	4
	• Climate.....	4
1.4	Impacts of Erosion and Sedimentation.....	6
1.4.1	Environmental Impacts.....	6
1.4.2	Economic Impacts.....	7

Chapter 2 PERMITTING PROCESS

2.1	Albany Municipal Code, Title 12.....	8
2.2	Permit Required.....	8
2.2.1	Permit Exemptions.....	8
2.3	EPSC Permit Process.....	9
2.3.1	Initial Site Review.....	9
2.3.2	Work Progress Inspections.....	9
2.3.3	Permit Close.....	9
2.4	EPSC Permit Requirements.....	10
2.4.1	EPSC Plan Required.....	10
2.4.2	Submittal Requirements for Minor Land Disturbing Activities.....	10
2.4.3	Submittal Requirements for Major Land Disturbing Activities.....	11
2.5	Wet Weather Conditions.....	13
2.6	Owner is Permit Holder.....	13
2.7	Permit Duration.....	13
2.8	Enforcement.....	13

Chapter 3 EPSC PLANNING AND DESIGN

3.1	Erosion Prevention vs. Sediment Control	15
3.2	Five Basic rules	15
3.3	Designer Responsibilities	16
3.3.1	Soil Survey Information	16
3.3.2	Climate and Precipitation Data	16
3.3.3	Topography	17
3.3.4	Revised Universal Soil Loss Equation (RUSLE)	17
3.3.5	Sensitive Areas; Waters of the State	17
3.4	Project Scheduling	18
3.5	Developing an Erosion Prevention and Sediment Control Plan	19
3.6	Internet Access Sites	22

Chapter 4 EPSC MEASURES AND BEST MANAGEMENT PRACTICES

Best Management Practices

4.1	Erosion Prevention	28
4.1.1	BMP 1: Preserve Natural Vegetation	28
4.1.2	BMP 2: Buffer Zone	29
4.1.3	BMP 3: Seeding (Temporary/Permanent)	30
4.1.4	BMP 4: Ground Cover	33
4.1.5	BMP 5: Hydraulic Application	35
4.1.6	BMP 6: Sod	36
4.1.7	BMP 7: Matting	37
4.1.8	BMP 8: Plastic Sheeting	43
4.1.9	BMP 9: Dust Control	46
4.1.10	BMP 10: Pipe Slope Drain	46
4.1.11	BMP 11: Outlet Protection	50
4.1.12	BMP 12: Surface Roughening	53
4.1.13	BMP 13: Check Dam	57
4.1.14	BMP 14: Diversion Dike/Swale	61
4.1.15	BMP 15: Grass-lined Swale	64
4.2	Sediment Control Practices	65
4.2.1	BMP 16: Sediment Fence	65
4.2.2	BMP 17: Biofilter Bags	68
4.2.3	BMP 18: Sand Bags	70
4.2.4	BMP 19: Filter Berm	71
4.2.5	BMP 20: Wattles	73
4.2.6	BMP 21: Compost Filter Stock	75
4.2.7	BMP 22: Sidewalk Subgrade Gravel Barrier	77
4.2.8	BMP 23: Inlet Protection	79
4.2.9	BMP 24: Dewatering	86
4.2.10	BMP 25: Sediment Trap	87
4.2.11	BMP 26: Sediment Basin	91
4.2.12	BMP 27: Flocculants and Coagulants	94
4.2.13	BMP 28: Construction Entrance	94
4.2.14	BMP 29: Tire Wash Facility	97

Chapter 5 POLLUTION CONTROL MEASURES AND BMPs

5.1	Management of Other Construction Site Pollutants	100
5.2	Pollution Control BMPs	106
5.2.1	BMP 30: Dewatering Operations	107
5.2.2	BMP 31: Paving Operations	107
5.2.3	BMP 32: Painting	108
5.2.4	BMP 33: Material Delivery and Storage	108
5.2.5	BMP 34: Material Use	110
5.2.6	BMP 35: Spill Prevention and Control	110
5.2.7	BMP 36: Solid Waste Management	112
5.2.8	BMP 37: Hazardous Waste Management	113
5.2.9	BMP 38: Contaminated Soil Management	114
5.2.10	BMP 39: Concrete Waste Management	115
5.2.11	BMP 40: Vehicle and Equipment Cleaning	115
5.2.12	BMP 41: Vehicle and Equipment Fueling	116
5.2.13	BMP 42: Vehicle and Equipment Maintenance	116
5.2.14	BMP 43: Employee and Subcontractor Training	117
5.2.15	BMP 44: Portable Toilet	118

Chapter 6 MAINTENANCE AND INSPECTION

6.1	Erosion and Pollution Control Manager	120
6.1.1	Ineffective Controls	120
6.2	Pre-Construction Meeting	121
6.2.1	Modified EPSC Plan	121
6.2.2	Construction Schedule Review	122
6.2.3	Monitoring Form	122
6.3	Materials	122
6.4	Installation	122
6.5	Inspection Requirements	122
6.5.1	Inspection of Work Restriction Areas	123
6.6	Stabilization Requirements	123
6.7	Erosion Control Contingency Items	123
6.8	Maintenance	124
6.8.1	Sediment Removal	124
6.8.2	Sediment Disposal	124
6.9	Inspector Checklist	124
6.9.1	Winterization	125
6.9.2	Designer/Inspector Toolbox	125

Appendix

Appendix A Sample EPSC Plans Submittal Requirements

Appendix B Contractor/Inspector Resources

Appendix C Glossary

CHAPTER 1: INTRODUCTION AND BACKGROUND

1.1 Introduction

This Erosion Prevention and Sediment Control (EPSC) Manual provides technical guidance for the design, installation, maintenance, and inspection of temporary and permanent erosion prevention and sediment control measures using Best Management Practices. The manual is intended for use by site designers, developers, contractors, and inspectors during all disturbed earth activities. These include clearing and grubbing, excavation, fill, construction, and any other activities that contribute to erosion and the movement of sediments. This manual is also intended to provide an educational resource to the public.

1.1.1 The Manual

The Erosion Prevention and Sediment Control Manual is divided into five chapters:

Chapter 1 Introduction and Background

This chapter provides an introduction to the manual with information regarding the background and basis for the City's development of erosion prevention and sediment control (EPSC) guidelines. This chapter also contains an overview of erosion processes and the environmental impacts created by erosion from disturbed earth activities.

Chapter 2 Permitting and Process

This chapter describes the requirements of the City of Albany's Erosion Prevention and Sediment Control Program. It defines the City's permitting requirements as set forth in Title 12 of the Albany Municipal Code and describes the related administrative processes.

Chapter 3 Erosion Control Planning and Design

This chapter discusses the issues important to the planning and design processes for an effective erosion prevention and sediment control plan.

Chapter 4 Erosion Prevention and Sediment Control Best Management Practices

This chapter presents best management practices (BMPs) for erosion prevention and sediment control on construction sites and is intended to help the designer choose the most appropriate measure or control.

Chapter 5 Pollution Prevention Housekeeping Best Management Practices

This chapter gives an overview of the environmental impacts created by pollution generated by construction site activities. The chapter describes planning and implementation activity controls that can be used on a construction site.

Chapter 6 Maintenance and Inspection

This chapter provides guidelines for the proper implementation, maintenance, and inspection of erosion prevention and sediment BMP control measures.

1.1.2 Goal Statement

It is the intent of this manual to describe proactive practices designed to prevent erosion and the release of sediments and other pollutants generated at a site of ground disturbance. Site planning and good site control are the best practices that can be used to prevent discharges. This manual is organized to emphasize measures preventing erosion and controlling stormwater runoff, as opposed to practices designed to strictly control sediment.

1.1.3 Disclaimer

This EPSC Manual was developed for the sole purpose of providing up-to-date erosion prevention and sediment control Best Management Practices (BMPs). The contents of this manual should not be interpreted as necessarily representing the policies or recommendations of other referenced agencies or organizations. The mention of trade names, products, or companies does not constitute an

endorsement.

It is intended this manual and alternative methods acceptable for use in other jurisdictions, will be reviewed on a regular basis, with the Manual updated as needed.

1.1.4 Common Acronyms

AOS	Apparent Opening Size
BMP	Best Management Practice
DEQ	Department of Environmental Quality
DSL	Division of State Lands
ECRM	Erosion Control and Revegetation Mats
EPA	Environmental Protection Agency
EPCM	Erosion and Pollution Control Manager
EPSC	Erosion Prevention and Sediment Control
HDPE	High Density Polyethylene Pipe
MS4	Municipal Separate Storm Sewer Systems
NPDES	National Pollutant Discharge Elimination System
OAR	Oregon Administrative Rules
ODOT	Oregon Department of Transportation
ORS	Oregon Revised Statutes
PCP	Pollution Control Plan
USLE	Universal Soil Loss Equation
RUSLE	Revised Universal Soil Loss Equation
TMDL	Total Maximum Daily Load
TRM	Turf Reinforcement Mats
TSS	Total Suspended Solids
USACE	U.S. Army Corps of Engineers

1.2 Background and Policies

It is the City of Albany's goal to comply with all conditions of Federal, State, County, and City regulations and requirements. This manual is intended to comply with current Willamette Basin Total Maximum Daily Load (TMDL) requirements and the anticipated requirements of a future National Pollutant Discharge Elimination System (NPDES) Phase II General Permit issued to the City of Albany for a Municipal Separate Storm Sewer System (MS4). Additionally, this manual is intended to comply with Title 12 of the Albany Municipal Code.

1.2.1 Total Maximum Daily Loads

In September 2006, the Department of Environmental Quality (DEQ) issued the Willamette River Basin Total Maximum Daily Load (TMDL) Order. The TMDL is a regulatory mechanism required under the Federal Clean Water Act, and TMDLs must be issued for streams that do not meet water quality standards. For the Willamette River, current levels of bacteria, temperature, and mercury exceed state water quality limits. The TMDL issued in 2006 is the beginning of a long-term plan to reduce the pollutant load in the river. It places requirements on cities, counties, state agencies, and federal agencies

and will be updated every five years as necessary. Every agency required to respond to the TMDL is labeled a Designated Management Agency (DMA).

The City of Albany is a DMA and is required to take steps to reduce the pollutant loads within our jurisdiction that contribute to the Willamette Basin. Because the TMDL is basin-wide, it applies not just to pollutants entering the Willamette River directly, but also to those entering tributaries to the Willamette, such as the Calapooia River and the creeks within Albany. The City's EPSC Program is one component of the City's efforts to meet TMDL requirements.

1.2.2 NPDES Program for Municipal Separate Storm Sewer Systems (MS4)

In 1990 the U.S. Environmental Protection Agency (EPA) began requiring large municipalities, those with a population of 100,000 or more, to obtain National Pollutant Discharge Elimination System (NPDES) permits for their Municipal Separate Storm Sewer Systems (MS4). In Oregon, the Department of Environmental Quality (DEQ) has been charged with administering the MS4 NPDES permit program. An MS4 is any stormwater conveyance system such as roads, ditches, gutters, catch basins, and storm drains owned or operated by a public body. These permits are known as "Phase I" permits and require communities to implement programs and practices that reduce the amount of stormwater pollutants discharged into local rivers and streams.

In December 1999, EPA adopted rules to implement "Phase II" of the stormwater program. Phase II expanded the stormwater permitting program to include smaller communities located in U.S. census-defined urban areas. Phase II rules require communities to develop, implement, and enforce stormwater management programs that address six minimum control measures. "Construction site runoff control" is one of six minimum control measures the City is required to include in its stormwater management program to meet the conditions of its NPDES MS4 Phase II Permit.

The City of Albany obtained a MS4 Phase II permit June 11th, 2021. The city has developed the EPSC program and this manual to protect water quality consistent with the Willamette Basin TMDL requirements discussed above and the NPES MS4 permit requirements.

1.2.3 City Municipal Code Title 12

In October 2009 the Albany City Council adopted Erosion Prevention and Sediment Control requirements as part of an update to Title 12 of the Albany Municipal Code (AMC). Specifically, Chapter 12.40 has been dedicated to Erosion Prevention and Sediment Control. Details of the City's EPSC program requirements, including permitting and inspection, are included in Chapter 2 of this manual.

1.2.4 1200-C Series Permits

The City of Albany's Erosion Prevention and Sediment Control Permit Program has met permit requirements to be a 1200-CN Jurisdiction. Under DEQ's 1200-CN Permit the City of Albany is authorized to permit construction activities under 5 acres. Activities affecting an area greater than five acres must obtain a DEQ 1200-C permit in addition to obtaining a city of Albany EPSC permit, [https://www.albanyoregon.gov/images/stories/cd/devcenter/forms/erosion_prevention_and sedi ment_control.pdf](https://www.albanyoregon.gov/images/stories/cd/devcenter/forms/erosion_prevention_and_sedi ment_control.pdf).

1.3 The Erosion and Sedimentation Processes

Figure 1-1

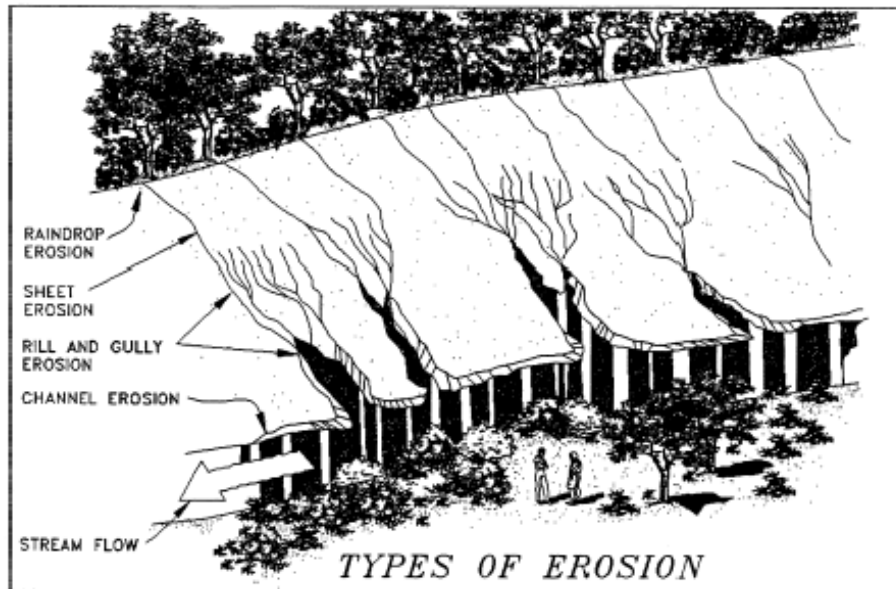

When land is disturbed at construction sites the soil erosion rate accelerates dramatically. The major problem associated with erosion at a construction site is the movement of soil from the site and the impact of the transported soil on water quality in streams, rivers, and wildlife habitat.

Erosion occurs when rain or wind loosens soils from the surface. Rain generated runoff cuts rills and larger gullies into exposed soils to convey sediment laden flows. Wind erosion creates a more consistent, area-wide stripping of soils from the soil surface. Both types of erosive forces are capable of depositing large amounts of sediment, sometimes at great distances, away from the site of ground disturbance.

There are four main factors that influence erosion:

❖ SOIL ERODIBILITY

Soil characteristics which influence the potential for erosion by rainfall and runoff are those properties which affect the infiltration capacity of a soil and those which affect the resistance of the soil to detachment and being carried away by falling or flowing water. The following four factors are important in determining soil erodibility:

- Soil texture (particle size and gradation)
- Percentage of organic content
- Soil structure
- Soil permeability

Soils containing high percentages of fine sands and silt are normally the most erodible. As the clay and organic matter content of these soils increases, the erodibility decreases. Clays act as a binder to soil particles, thus reducing erodibility. However, while clays have a tendency to resist erosion, once eroded, they are easily transported by water. Soils high in organic matter have a more stable structure which improves their permeability. Such soils resist raindrop detachment and infiltrate more rainwater. Clear, well-drained, well-graded gravel, and gravel-sand mixtures are usually the least erodible soils. Soils with high infiltration rates and permeability either prevent or delay and reduce the amount of runoff.

❖ **VEGETATIVE COVER**

Vegetative cover plays an extremely important role in controlling erosion as it provides the following five benefits:

- Shields soils surface from raindrop and wind erosion
- Provides root systems which hold soil particles in place
- Aides soil in absorbing water
- Slows velocity of runoff
- Evapotranspirates sub-surface water between rainstorms

By limiting and staging the removal of existing vegetation and by decreasing the area and duration of exposure, soil erosion and sedimentation can be significantly reduced. Special consideration shall be given to the maintenance of existing vegetative cover in areas of high erosion potential such as moderately to highly erodible soils, steep slopes, drainageways, and the banks of streams.

❖ **TOPOGRAPHY**

Topography (the size, shape, and slope) of a watershed can influence the amount and rate of stormwater runoff. High slope lengths and steep gradients increase the rate of runoff (creating a higher probability for erosion) and can limit abilities to establish and maintain vegetative cover.

❖ **CLIMATE**

The frequency, intensity, and duration of rainfall are fundamental factors in determining the amounts of runoff produced in a given area. As both the volume and velocity of runoff increases, the capacity of runoff to detach and transport soil particles also increases. Where storms are frequent, intense, or of long duration, erosion risks are high. Seasonal changes in temperature, as well as variations in rainfall, help to define the high erosion risk period of the year. When precipitation falls as snow, no erosion will take place. However, when the temperature rises, melting snow adds to runoff, and erosion hazards are high. Because the ground is still partially frozen, its absorptive capacity is reduced. Frozen soils are relatively erosion resistant. However, soils with high moisture content are subject to uplift by freezing action and are usually very easily eroded upon thawing. Although both water and wind erosion should be anticipated throughout the year, the likelihood of water erosion increases during the wet weather months (October 1st – April 30th) and wind erosion is more prevalent during the dry weather months.

Every year, tons of sediment are washed and blown from sites of ground disturbance into streams, rivers, and lakes. The U.S. Environmental Protection Agency estimates approximately 600 million tons of soil erodes from U.S. construction sites alone each year (1993). As the community continues to grow, our local waterways are being affected by ground disturbance with the greatest sediment impacts occurring during the land grubbing, clearing, grading and other excavation phases of development.

Responsible development requires that steps be taken to control erosion and sedimentation from construction sites. Figure 1-2 demonstrates the ability of good erosion and sediment control measures, versus no controls, in minimizing the detrimental effects of sedimentation.

This chart also demonstrates the fact that once a naturally vegetated area has been developed, sediment levels can be twice the pre-development rate. It is well known that the erosion and sediment threat is greatest during construction. Once development is complete (stabilization techniques implemented), there is a dramatic decrease in the pollutant level yield.

Figure 1-2

STORM MEDIAN SEDIMENT CONCENTRATION (mg/l)

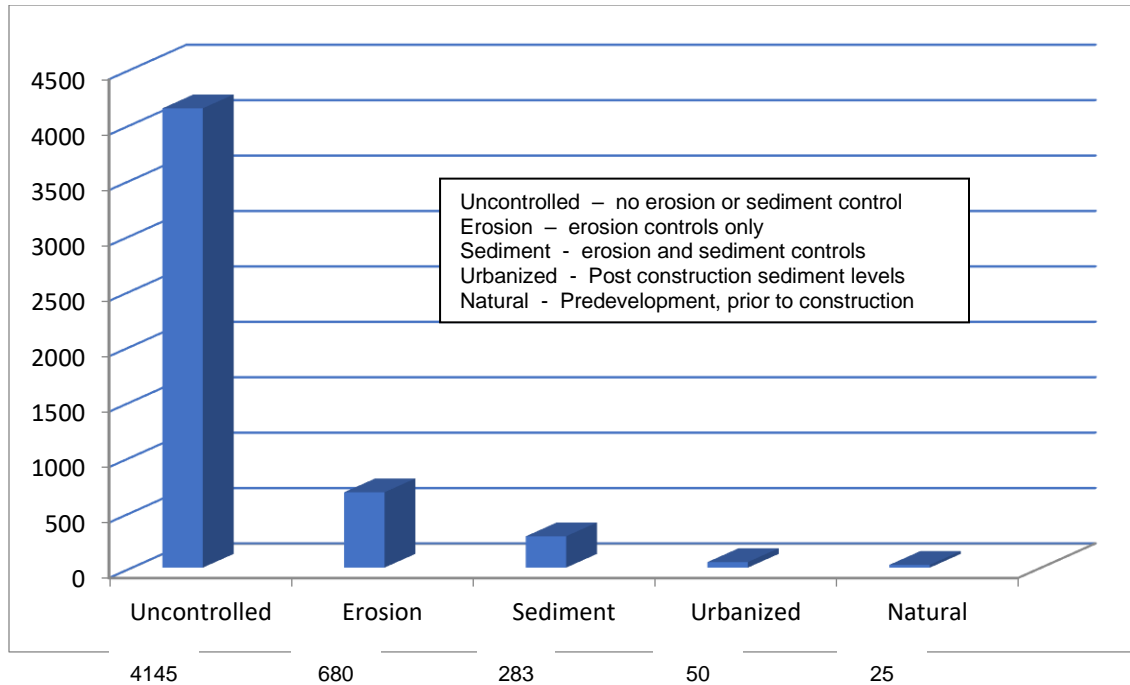

Source: Performance of Current Sediment Control Measures at Maryland Construction Sites, Metropolitan Washington Council of Governments

Sediment, resulting from disturbed soil, can move onto neighboring properties and streets or into drainage systems and other bodies of water. Excessive sediment has significant negative impacts on how the natural watershed runoff and soil conveyance system works. Under natural conditions, runoff moves through a watershed as groundwater through infiltration or as surface water by spreading across floodplains and migrating downstream through stable stream and waterway channels. In a natural watershed system, sediment, cobbles, and gravel travel throughout the stream network creating deposition, scour and gravel areas that are important for fish habitat. The natural system survives by its ability to contain flows and balance sediment loads within the stream network.

1.4 Impacts of Erosion and Sedimentation

Erosion and sedimentation cause both environmental and economic impacts. Both are important but it is often only an economic impact that spurs a jurisdiction to take action. Environmental impacts are harder to see and quantify as they tend to build slowly and do not produce dramatic results for many years when it may be too late to correct the problem. Erosion and sedimentation can cause expensive site damage and construction delays. Lack of maintenance often results in failure of control practices and costly cleanup and repairs.

1.4.1 Environmental Impacts

Many environmental impacts from sediment pollution are cumulative and the ultimate results and costs may not be evident until years later. Some environmental impacts include:

- Eroded soil contains nitrogen, phosphorus, and other nutrients. When carried into water bodies, these nutrients trigger algal blooms that reduce water clarity, deplete oxygen, lead to fish kills, and create odors.

- Erosion of streambanks and adjacent areas destroys streamside vegetation that provides aquatic and wildlife habitats.
- Excessive deposition of sediments in streams smothers the bottom fauna, seals stream beds, and destroys fish spawning habitat.
- Turbidity from sediment reduces in-stream photosynthesis, which leads to reduced food supply and habitat.
- Turbidity increases the amount of sunlight absorbed in water, raising stream temperatures.
- Suspended sediment abrades and coats aquatic organisms.
- Erosion removes the smaller and less dense constituents of topsoil - those clays, fine silt particles and organic materials that hold nutrients that plants require for healthy establishment. The remaining subsoil is often hard, rocky, infertile, and fails to hold moisture; thus, making re-establishment of vegetation difficult.

1.4.2 **Economic Impacts**

Many economic impacts are hard to quantify. How can a dollar value be assigned to loss of aquatic habitat or diminished water clarity? Other impacts may be readily quantified, for example the cost of dredging and disposing of the accumulated sediment in a silted-up reservoir. Some potential economic impacts include:

- Excessive sediment accumulation reduces reservoir storage capacity and more frequent sediment removal is required.
- Sediment deposited into streams reduces flow capacity, interferes with navigation, and increases the risks of flooding.
- Local governments and their taxpayers must pay for removing sediment from streets, sewers, ditches, sumps, and culverts, and for dredging sediment from harbors and navigation channels
- Excess sediment creates cloudy or turbid water conditions, interfering with recreational uses.
- Erosion severely diminishes the ability of the soil to support plant growth. To restore this ability is costly.
- Loss of wildlife habitat due to erosion and sedimentation could lead to additional species being classified as endangered. Additional endangered species listings increase time and fees for permitting, design, and construction in the affected watersheds. Some costs are directly assessed to specific projects while many other costs are distributed statewide by spending additional monies for habitat restoration.
- Litigation is an expensive alternative.

Many of these costs could be largely avoided through implementation of adequate erosion control practice.

CHAPTER 2: PERMITTING PROCESS

2.1 Albany Municipal Code, Title 12

Title 12, “Surface Water,” of the Albany Municipal Code (AMC) has been adopted to “provide for the health, safety, and general welfare of the citizens of the City of Albany and to protect and enhance the water quality and natural functions of watercourses and water bodies through the regulation of stormwater discharges; to set forth uniform requirements for direct and indirect contributors to the Municipal Separate Storm Sewer System; and to enable the City of Albany to comply with applicable state and federal laws.”

Chapter 12.40 of Title 12 sets forth the requirements of the City’s Erosion Prevention and Sediment Control Program. Included in that Chapter is a provision for the development, implementation, and maintenance of this manual. In the event that any provision of this manual is in conflict with any section of the AMC, the provisions of the AMC shall govern.

2.2 Permit Required

The City of Albany requires an EPSC permit before commencing land disturbing activities affecting an area of 2,000 square feet or greater, cumulatively. The City of Albany is a 1200 CN jurisdiction, authorized to permit projects up to 5 acres of disturbance. Construction activities affecting an area greater than five acres must obtain a DEQ 1200-C permit in addition to obtaining a City of Albany EPSC permit.

Waterway Adjacent Disturbance means the disturbance takes place within 50 feet of any waterway. Waterway adjacent disturbances will require an EPSC permit, regardless of disturbed land area, on a case-by-case basis, depending on the scope of work performed. BMP determination and sizing will be based off the USDA (RUSLE2) software.

Permits must be obtained by the owner of the property on which the activity is proposed. As part of the application, the owner must sign a statement of financial responsibility for damages resulting from noncompliance with EPSC requirements.

Except as otherwise exempted within the definitions of Title 12 of the Albany Municipal Code (AMC), all land disturbing activities, whether or not qualifying for permit requirements, shall be undertaken in a manner to prevent or minimize, to the greatest extent practical, soil erosion and the deposition of sediments onto rights-of-way; or introduction of sediments into wetlands, drainage ways, the municipal stormwater system, receiving waters, and/or areas that contain or contribute directly to the Waters of the State.

Approval of an erosion prevention and sediment control plan and permit issuance by the City does not relieve the applicant of his or her responsibility to ensure erosion prevention and sediment control BMPs are implemented and maintained effectively.

COMMON PLAN OF DEVELOPMENT

A “Common Plan of Development or Sale” as defined by the DEQ is a plan to subdivide a parcel of land into separate parts for separate sale. This can be for residential, commercial, or industrial development. A construction activity is part of a larger common plan of development if it is completed in one or more of the following ways: in separate stages, in separate phases, and/or in combination with other construction activities.

2.2.1 Permit Exemptions

Some land disturbing activities that affect an area greater than 2,000 square feet do not require a permit. These include:

- Replacement or re-establishment of an existing lawn on a single lot, not exceeding 7,000 square feet (about a quarter of an acre)
- Agricultural activities. This is defined as “private or commercial activities directly engaged in the production of nursery stock, sod, fruits, vegetables, forages, cover crops, field crops (grain,

corn, oats, beans, etc.) timber, and livestock, or other related activities determined by the Director [of the Public Works Department] to conform to this definition; but shall not include construction or other activities for structures associated with agricultural activities.” This definition includes home gardening.

Regardless of whether or not a permit is required, all land disturbing activities must be performed in a manner to prevent or minimize, to the greatest extent practical, soil erosion and the deposition or introduction of sediments upon or into rights-of-way; wetlands, drainage ways, the MS4, receiving waters, and/or areas that include or contribute directly to the Waters of the State.

2.3 EPSC Permit Process

Upon receipt of an application for an EPSC permit, the Director, or his or her designee, will review the submitted application and attached EPSC Plan. Upon preliminary approval of the EPSC plan the Director will schedule an appointment to meet the applicant on site to review the installed BMPs and verify that they match the EPSC plan. The EPSC permit will not be issued until after the initial site review has been conducted and the EPSC plan has been accepted. No land disturbing activities may commence until an EPSC permit has been issued.

2.3.1 Initial Site Review

EPSC BMPs shall be installed at the time of the initial site review. The site review provides the inspector and the applicant the opportunity to review the components of the EPSC Plan, and the accuracy of the plan as it reflects actual site conditions. The inspector may require changes to the EPSC Plan, installed BMPs, or other provisions deemed necessary.

Subsequent to the City’s approval of the EPSC Plan and acceptance of the installed BMPs, the EPSC permit will be issued. Land disturbing activities may only commence after an EPSC permit has been issued.

2.3.2 Work Progress Inspections

During all periods of land-disturbing activities an EPSC inspector will visit the work site to monitor the effectiveness of the EPSC plan. The EPSC BMP measures shown on the approved plan are minimum requirements for anticipated site conditions. During construction, it may be necessary for the EPSC plan to be changed or augmented for changing conditions, and to ensure that sediment and sediment-laden water does not leave the site. The inspector will assess the effectiveness of BMPs, ensure they are being properly maintained, and make recommendations for changes or additions as necessary. The inspector will leave a written notice on-site or otherwise contact the responsible person with any required corrections and a re-inspection date. Site inspections may occur on any frequency as determined by the inspector.

2.3.3 Permit Close

After the completion of all land disturbing activities, the owner will make a request to the city to perform a final inspection. Upon verification by the inspector that permanent site stabilization measures have been installed and are functioning effectively, the EPSC permit will be closed. No “in lieu of” work may be substituted for permanent stabilization within any public right-of-way.

Final Stabilization shall be the following:

- No exposed soils and temporary stabilization measures have been replaced with permanent stabilization measures.
- Uniform vegetative cover with a density of 90 percent on all vegetative areas. Grass shall be mature to survive (approx. 2-inch in height).
- Two-inch layer of mulch, bark, or wood chips.

- Construction of all impervious surfaces and permanent structures.
- Post-construction permanent stabilization measures have been employed (riprap, gabions, etc.).

2.4 **EPSC Permit Requirements**

Submittal requirements for EPSC permits for various types of construction projects are presented below. This information will provide the necessary tools to facilitate City approval and reduce overall environmental risks. The City of Albany issues two types of EPSC permits: one for minor land disturbing activities and one for major land disturbing activities. Each activity is described in the following sections.

2.4.1 **EPSC Plan Required**

Applicants for an EPSC permit shall submit an EPSC Plan as a part of their permit application. For minor land disturbances defined in Section 2.4.2 there are no special qualifications to prepare the plan. For major land disturbing activities defined in Section 2.4.3 a professional design must be submitted by a person licensed in Oregon as a civil engineer, environmental engineer, landscape architect, geologist, or a certified professional in erosion and sediment control (CPESC). EPSC Plan procedures for planning and design are described in Chapter 3 of this manual. Sample EPSC plans and details can be found in Appendix A.

Approval of an EPSC plan by the City of Albany does not relieve the applicant of his or her responsibility to ensure the approved EPSC best management practices are constructed and maintained to prevent erosion and contain sediment and pollutants on the construction site. Additional EPSC best management practices (BMPs) beyond those depicted on an approved EPSC plan may be required based on specific site conditions.

Erosion prevention and sediment control BMPs are required during all land disturbing activity until permanent site ground covers are in place. Certain base measures are required for construction sites at all times of the year.

2.4.2 **Submittal Requirements for Minor Land Disturbing Activities**

An EPSC permit is required for all land-disturbing activities affecting an area of two thousand square feet or greater, cumulatively.

This section provides the submittal requirements to obtain an EPSC permit for minor land disturbances. Sites meeting the following conditions can be characterized as *minor land disturbances*:

1. Individual single-family home or duplex construction on existing lots of record, or manufactured home placement on individual lots or in manufactured home parks, and meet the following conditions:
2. Land disturbing activities that cumulatively affect less than one acre throughout the duration of the project and meet the following conditions:
 - a. Average slopes throughout the disturbed area do not exceed 10 percent, and
 - b. Slopes within the disturbed area do not exceed six feet in height at slopes greater than 3:1 (horizontal: vertical), and
 - c. Concentrated runoff conveyed through the site does not originate from more than one acre off-site (outside of disturbed area), and
 - d. There are no sensitive areas (wetlands, streams, etc.) located on, or adjacent to, the sitework.

Table 4-2 designates the minimum erosion control BMPs for minor land disturbances. Each erosion control BMP presented in the table is also described in further detail with design, construction, and maintenance criteria in Chapter 4.

Each application for an EPSC permit for minor land disturbances shall include:

- 1 A completed City of Albany EPSC permit application form.
- 2 An EPSC Plan, drawn to scale, showing the following (See Chapter 3 for Plan Development):
 - a. Property lines and distances to buildings
 - b. Elevations on the property to indicate the amount of fall and/or grades across the property
 - c. Contour lines showing the existing grades/topography of the site
 - d. Contour lines showing the proposed final grades/topography of the site
 - e. Arrows to indicate existing and final flow patterns of surface water on the property. It is the property owner's responsibility not to alter the flow of surface water in such a manner as to harm neighboring properties.
 - f. Proximity to sensitive areas, as defined in Section 3.3.5
 - g. Location of the 100-year flood plain, if applicable
 - h. Location and size of drainage ways, swales, ditches, etc.
 - i. Location of utilities on the property (sewer, water, etc.)
 - j. All areas of land disturbances, including areas that will be cleared, graded, or excavated
 - k. Location for storage of soil and/or waste
 - l. Gravel construction entrance
 - m. Placement of erosion prevention and sediment control BMPs (e.g., sediment fences)
- 3 A construction schedule showing:
 - a. Expected date by which EPSC measures will be in place
 - b. Expected date land-disturbing activities will commence
 - c. Expected date construction will be completed
 - d. Expected date permanent ground cover will be in place

If the facilities and techniques approved in an EPSC Plan are not effective or sufficient, the applicant shall:

- Take immediate action to stop eroded material and/or sediment from leaving the site
- Immediately implement additional facilities and techniques as approved by the Director or his or her designee
- Prepare and submit a revision to the EPSC Plan for City approval

2.4.3 Submittal Requirements for Major Land Disturbing Activities

An EPSC permit is required for all land-disturbing activities affecting an area of 2,000 square feet or greater, cumulatively. Major land-disturbing activities include those sites that:

- Affect an area over an acre in size, or
- Contain average slopes throughout the disturbed area that exceed 10 percent, or
- Contain slopes greater than 3:1 which exceed six feet in height, or
- Have concentrated runoff through the disturbed area that comes from over one acre off-site, or
- Contain sensitive areas.

Tables 4-3 and 4-4 designate the minimum erosion control BMPs for major land disturbances. Each erosion control BMP presented in the table is also described in further detail with design, construction, and maintenance criteria in Chapter 4.

The applicant shall submit the following information with construction plans for subdivision approval, grading, building, or erosion control permit:

1. Completed Erosion Prevention and Sediment Control Permit Application form

2. A copy of any applicable NPDES 1200-C permit issued by the Department of Environmental Quality (DEQ). If the site is subject to the requirements of an NPDES 1200-C permit, but it has not been issued, the City will not issue an EPSC permit.
3. Construction schedule with the following information:
 - a. Construction start and completion dates
 - b. Dates when erosion control measures will be in place
 - c. Timing of site clearing and grading, placement of fills, and excavations
 - d. Projected date of removal of erosion control measures (after landscaping is established or after establishment of a healthy grass stand or other approved vegetation)
4. Submit with the construction plans three sets of the EPSC Plan, drawn to scale, showing the following (See Chapter 3 for Plan development processes):
 - a. Vicinity map, property address, and property owner's name and address
 - b. Locations, types, and applicable dimensions of erosion control measures
 - c. Applicable details of erosion control measures showing full dimensions and construction information
 - d. Existing and proposed ground contours, including a minimum of the first 50 feet of abutting property
 - e. Arrows to indicate existing and final flow patterns of surface water on the property. **Note: it is a violation of Oregon Drainage Law to alter the flow of surface water to harm neighboring properties**
 - f. Locations and sizes of existing and proposed channels and drainage pipes (labeled as such and with arrows indicating flow direction) on and for 100 feet upstream and downstream of the site
 - g. Location of the 100-year flood plain, if applicable
 - h. Site entrances/exits (as approved by the city)
 - i. Applicable standard erosion control notes from Appendix A, with additions or changes as required
 - j. Other notes including references to timing of placement and removal of erosion control measures, and erosion measure specifications such that types and quantities of materials necessary for the installation of the erosion control measures are fully detailed
 - k. Stamped or signed by a certified professional licensed in Oregon as a civil or environmental engineer, landscape architect, geologist, or certified professional in erosion and sediment control (CPESC)**

If the site erosion control plan includes sediment traps or ponds, the applicant shall also submit calculations used for determining trap or pond sizing and pipe orifice sizing.

Because of particular site conditions or preferences, the applicant may desire in certain cases to use different erosion control measures than those recommended in Tables 4-2 or 4-3. In such cases, the applicant must submit calculations or other supporting information used to determine the sizing and layout of the measures shown on the submitted erosion control plan.

Cumulative land disturbing activity in excess of one acre requires a NPDES 1200-C stormwater general permit issued by the DEQ. As indicated above, a copy of the NPDES 1200-C application is required to be submitted to the City of Albany.

If the facilities and techniques approved in an EPSC Plan are not effective or sufficient, the applicant shall:

- Take immediate action to stop eroded materials and/or sediment from leaving the site

- Immediately implement additional facilities and techniques as approved by the Director, or his or her designee
- Prepare and submit a revision to the EPSC Plan for City approval

2.5 **Wet Weather Season**

The project site is required to manage runoff from the site year around. Wet weather season is from October 1st through April 30th.

Rain is the driving factor behind most erosion in this region. Rainfall impact and surface water runoff over exposed soil dislodges sediment particles, suspending them in moving water. Saturated soils are more easily tracked off site by equipment. During the wet weather season or when rain is forecasted additional Erosion Prevention and Sediment Control BMPs are required. The project shall have these BMPs onsite and readily available year around. These include but are not limited to:

Emphasize Prevention

- Seed exposed soils by September 1st to allow time for proper germination and growth
- Maintain clean rock in construction entrances to minimize off-site tracking and expensive cleanup.
- Sweep and remove any off-site tracking immediately. *Street flushing is prohibited.*

Cover all Exposed Soil

- Stabilize all exposed soil by seeding or covering it with plastic sheeting or a two-inch layer of mulch, bark, wood chips, sawdust, or straw to minimize erosion potential.
- For slopes greater than 3:1 (33 percent), stabilize exposed soil with erosion blankets or matting.
- Use diversion dikes and swales to divert runoff away from work areas with exposed soil.

2.6 **Owner is Permit Holder**

EPSC permits must be obtained by the owner of the property. The owner of the property, as permit holder, shall assume responsibility for site conditions, maintenance of the EPSC Plan, and maintenance of BMPs throughout the duration of land-disturbing activities, and until such time as the site has been adequately stabilized and the permit has been closed or transferred. Permits may not be transferred to any person or entity except upon transfer of title for the property.

When the ownership of a property with an active EPSC permit is transferred, the person(s) or entity transferring title for the property is obligated by Albany Municipal Code to inform the person(s) or entity assuming ownership of their obligation to transfer the EPSC permit, or to obtain a new permit.

The most recent EPSC permit for a property will supersede all other EPSC permits that apply to that property. For example, this provision allows for an EPSC permit to be issued for the development of a subdivision. Subsequently, individuals or entities may obtain a permit for a lot within that subdivision while the subdivision's original EPSC permit is still active. The subsequent permit for the individual lot will then nullify the obligations of the subdivision's developer for the affected lot.

2.7 **Permit Duration**

EPSC permits are valid for a period of one year, or until land disturbing activities are completed, and surface conditions stabilized with permanent measures to prevent future erosion. If land disturbing activities continue beyond the permit's expiration date, or if the land has not been permanently stabilized, the permit holder may make a written request for an extension. Extensions, if approved, shall be for twelve months and will be subject to administrative fees.

2.8 **Enforcement**

To enforce the requirements of the City's EPSC program, the Public Works Director, or his or her designee may gain compliance by any or all of the means described below.

Progressive Enforcement Actions (First Offense):

- Step 1: Verbal Notification to make corrections within stated* timeline(s).
If contractor doesn't respond appropriately/timely, proceed to Step 2.
- Step 2: Written Notification to make corrections within stated* (and reasonable) timeline(s) **If contractor doesn't respond appropriately/timely, proceed to Step 3.
- Step 3: Issue a "Stop Work" order; remains in effect until corrections are completed.
- Step 4: If contractor fails to respond in a timely fashion, City abates the situation by hiring an erosion control specialty contractor to address the site and make necessary corrections.

Progressive Enforcement Actions (Second Offense):

- Step 1: Written Notification to make corrections immediately and issue administrative fine.
If the contractor doesn't respond appropriately proceed to Step 2.
- Step 2: Issue a "Stop Work" order and issue progressive administrative fine. Remains in effect until corrections are completed.
- Step 3: If contractor fails to respond in a timely fashion, City abates the situation by hiring an erosion control specialty contractor to address the site and make necessary corrections.

Progressive Enforcement Actions (Third Offense):

- Step 1: Issue a "Stop Work" order and provide prescriptive corrections that must be completed immediately and issue progressive administrative fine. Remains in effect until corrections are completed and/or City initiates abatement actions (which will be charged back to the Contractor).
- Step 2: If contractor fails to respond in a timely fashion, City abates the situation by hiring an erosion control specialty contractor to address the site and make necessary corrections.

Other Enforcement Actions for Significant Non-Compliance:

Engaged in active work prior to preliminary EPSC permit approval and initial site review: Issue a "Stop Work Order".

If Contractor continues to work after a "Stop Work Order" has been issued: Issue an administrative fine and notify Albany PD to escort Contractor personnel not engaged in addressing the EPSC violation(s).

Administrative Fine Schedule Guidelines:

First Offense:	\$250*** if unintentional, \$500*** if willful
Second Offense:	\$750*** if unintentional, \$1,500*** if willful
Third Offense:	\$1,500*** if unintentional, \$2,500*** if willful
Third + Offense:	\$2,500***
Abatement:	Actual cost (i.e. service provider invoice + City overhead charges)

**Typical response timeline is less than 24-hours and not greater than 48-hours*

***May include a Compliance Schedule*

****Each day upon which a violation occurs or continues shall constitute a separate violation*

No action taken by the Public Works Director, or his or her designee, will be contingent on any requirement for any preceding or qualifying action on the part of the Director, or his or her designee.

No enforcement action taken by the Director, or his or her designee, will limit the authority of the Director from taking any other action available.

CHAPTER 3: EPSC PLANNING AND DESIGN

The purpose of erosion and sediment control planning is to clearly establish the BMP control measures which are intended to prevent erosion and off-site pollutants such as sediment from entering the storm system or leaving the site during construction. The Erosion Prevention and Sediment Control (EPSC) Plan must describe the site development and serve as a blueprint for the location, installation, and maintenance of practices to control erosion and prevent pollutants from leaving the site during construction. It should also be understood that plans are only a blueprint and will require modification throughout the life of the project.

3.1 Erosion Prevention vs. Sediment Control

The driving consideration in creating and implementing an effective EPSC plan is to provide erosion prevention measures rather than sediment control. Although every EPSC plan will have elements of both, it is often far more cost effective and practical to emphasize erosion prevention. Erosion prevention BMPs are designed to prevent exposed soil particles from becoming dislodged by rain or wind. Such measures include temporary ground covers (mulch, temporary grasses, straw mulch, and tackifier, etc.), matting, plastic sheeting, and numerous other products designed to provide mechanical or physical protection to exposed soil. Sediment control involves techniques to re-capture transported sediment from runoff. Sediment BMPs include sediment traps and basins, sediment fences, check dams, sediment barriers, catch basin filters, etc.

The benefit of erosion prevention is that it seeks to prevent the problem before it starts. It is also often impractical to recover large amounts of sediment after it becomes dislodged and suspended in runoff. On projects where the predominant soil particle size is very small (fine silts and clays, typical of Albany), the amount of time required to allow for settling of solids can reach days or even weeks. It is also generally true that erosion prevention measures are more reliable, whereas sediment BMPs require continual and costly maintenance. Because successful erosion prevention requires minimizing disturbed areas, the EPSC plan must emphasize scheduling and phasing. Project scheduling and phasing is often driven by factors other than erosion control, however, so contingency planning is essential. Most importantly, the EPSC plan is to be designed and implemented as a living, dynamic plan that can be adapted to address changes in the project as work progresses.

3.2 Five Basic Rules

Erosion BMPs are required for construction areas where the ground surface will be disturbed by clearing, grading, fills, excavations, and other construction activities. When developing an effective EPSC plan, there are several important concepts to consider:

- Timing – phase work schedule to minimize exposed soils and overall impacts
- Stage work – identify and process critical areas first
- Minimize disturbance – create buffers and reduce mass grading
- Pre-construction – during preliminary design and prior to on-site grading activities
- Pictures/Video – documentation throughout life of project

The long-term benefits of an effective erosion and sediment control plan are enormous. An important concept to keep in mind when developing construction and erosion control plans is: **practices which minimize the amount of disturbed land area and avoid or minimize work on steep slopes have the greatest potential to reduce erosion.** There is less chance of soil washing off the site and clogging streets, drainage systems, and entering adjacent properties. The number and size of erosion control measures required will be minimized. The cost of maintaining erosion control facilities is minimized. Topsoil retention on the site is maximized, making re-vegetation and landscaping easier to establish.

It is equally important to note that approval of an erosion and sediment control plan by the City of Albany does not relieve the applicant's responsibility to ensure erosion control measures are constructed and maintained to prevent sediment from leaving construction site. These requirements are upheld throughout the life of the construction project.

3.3 Designer Responsibilities

A designer generally puts the EPSC plan together in the office based on information provided from resources obtained from local and regional agencies and a detailed field site visit. In addition, the designer must identify potential erosion and sediment problems, develop design objectives, formulate and evaluate alternatives, select the best erosion prevention measures, and develop a plan. A determination is made about what best management practices are appropriate. A variety of BMPs should be included on the plan in order to provide adequate tools in the field. By following the step-by-step process listed below, designers can improve overall success.

Stormwater control factors to consider while designing an EPSC plan:

- a. The expected amount, frequency, intensity, and duration of precipitation
- b. The nature of stormwater runoff and run-on (See definitions) at the site, including factors such as expected flow from impervious surfaces, slopes, and site drainage features
- c. The soil type and range of soil particle sizes expected to be present on the site

The stormwater controls must be designed to control stormwater volume, velocity, and peak flow rates to prevent discharges of pollutants in stormwater and to prevent channel and streambank erosion and scour (i.e. hydromodification) in the immediate vicinity of discharge points. Design and install of all stormwater controls in accordance with appropriate, recognized and generally accepted engineering and professional practices, including applicable design specifications and manufacturer's instructions. See section 3.3 of the City of Albany Engineering Standards for conveyance and volume-based BMP's. For questions and access to BMP sizing software (RUSLE2), see ars.usda.gov.

A designer will need to submit an Environmental Management Plan (EMP) to DEQ for approval for the use of any stormwater or soil additives that require additional testing. Such additives include but are not limited to engineered soils, cement treated bases, and flocculants/coagulants. The designated person, whether contractor or erosion and sediment control specialist, and ultimately the owner, has a defined responsibility to prevent pollution from leaving the site. He or she must follow a plan, or obtain approval for a revised plan, and ensure the site is stable. Even though the EPSC plan may be followed in detail and appear to have addressed all issues, there will inevitably be obstacles along the way that will change those plans. Therefore, the best scenario includes a good plan, open lines of communication, and defined responsibilities.

3.3.1 Soil Survey Information

Knowing the type of soil found on the project site will help the designer decide upon the degree of erosion protection required. Of prime importance are the predictions of soil behavior for selected land uses. As explained in Chapter 1, the potential for erosion is highly dependent on the type of soil. This will ensure the EPSC plan is adequate to control soil movement without being overly conservative. The Natural Resource Conservation Service Soil Survey, a mapped inventory with physical properties and characteristics described for each soil type for Linn and Benton Counties is available on the Internet at http://www.or.nrcs.usda.gov/pnw_soil/or_data.html

3.3.2 Climate and Precipitation Data

The occurrence and intensity of rainfall is important for the designer when placing and sizing erosion control measures. Additionally, all erosion control measures require inspection after any rain event in excess of 0.25 inches in 24 hours. Rain gauges can be used to assist in determining on-site rainfall. Precipitation and other weather data may be found on the internet through the Oregon State University, College of Agricultural Sciences, Hyslop Weather Station, at

<https://agsci.oregonstate.edu/hyslop-weather-station>. The wet weather season extends from October 1st to April 30th.

3.3.3 Topography

From the site visit, determine the drainage patterns from the topography. Does runoff flow from offsite through the construction site? If so, measures must be taken to re-route this water around areas that will have ground disturbance.

Will areas of ground disturbance occur on long slopes that are greater than two percent grade? If so, the lengths of the uninterrupted flows should be broken up so the rainfall runoff will only flow short distances thereby decreasing flow velocity and the erosive force. In flat areas, runoff is slow and soil particles are not moved far from the point of raindrop impact. If the slopes are steep and short, surface cover may be needed to decrease runoff and promote rainfall infiltration into the soil. On steep slopes, soil movement increases dramatically. Constructing very long slopes and especially, long, steep slopes should be avoided. Those that already exist should not be disturbed.

3.3.4 Revised Universal Soil Loss Equation (RUSLE)

In order to properly design sediment basins and large conveyance structures, a designer must be able to calculate the quantities of water and sediment that will be managed by the structure. The design method for calculating soil loss from disturbed land is the Revised Universal Soil Loss Equation (RUSLE). RUSLE estimates soil loss from a slope caused by raindrop impact and overland flow (collectively referred to as “inter-rill” erosion), plus rill erosion. It does not estimate gully or stream-channel erosion. RUSLE is a tool to estimate the rate of soil loss based on site-specific environmental conditions and a guide for the selection and design of sediment and erosion control systems for the site. RUSLE does not determine when soil loss is excessive at a site, when erosion control systems have failed, or sediment yield once it has left the site. The RUSLE user makes such decisions based on numerous criteria, of which soil-loss and sediment-yield estimates are an important compound.

For a complete copy of the guidelines and the public domain RUSLE software visit:

<https://www.nrcs.usda.gov/resources/tech-tools/water-erosion-rusle2>

online or contact:

Chris Coreil, National Erosion Specialist
National Resource Conservation Service
Central National Technology Support Center
Fort Worth, Texas
Phone: (817) 509-3213
E-mail: chris.coreil@usda.gov

3.3.5 Sensitive Areas; Waters of the State

Sensitive areas include steep slopes (those greater than 10 percent), wetlands, and areas that include or contribute directly to Waters of the State. “Waters of the State” means any lakes, bays, ponds, impounding reservoirs, springs, wells, rivers, streams, creeks, estuaries, marshes, inlets, canals, the Pacific Ocean within the territorial limits of the State of Oregon and all other bodies of surface or underground waters, natural or artificial, inland or coastal, fresh or salt, public or private (except those private waters that do not combine or effect a junction with natural surface or underground waters), which are wholly or partially within or bordering the State or within its jurisdiction.

Depending on several factors, an undisturbed corridor buffer of varying width is required adjacent to sensitive areas. Sensitive areas shall be delineated and marked in the field prior to work commencing. The responsible party shall be aware of, and adhere to, any limitations in the work area in the proximity of sensitive areas imposed by environmental permits issued by the Division of State Lands (DSL), the U.S. Army Corps of Engineers (USACE), and the Federal Emergency Management Agency (FEMA).

Wetland Delineations require the approval of the DSL. This includes work pertaining to, but not limited to:

- work in or over “navigable waters” of the United States, or which affects the course, location, condition, or capacity of such waters
- the removal of material from, or placement of fill material into, the “Waters of the State,” including wetlands, and
- work within floodways, as mapped by FEMA

3.4 Project Scheduling

Following a specified work schedule that coordinates the timing and land disturbing activities and the installation of BMPs with stabilization is perhaps the most cost-effective way of controlling erosion during construction. The removal of ground cover leaves a site vulnerable to accelerated erosion. Construction procedures that limit land clearing, provide the timely installation of erosion prevention and sedimentation controls, and restore protective cover quickly can significantly reduce the erosion potential of a site.

Construction projects must be sequenced to reduce the amount and duration of soil exposure to erosion by wind, rain, runoff, and vehicle tracking. The construction schedule is an orderly listing of all major land disturbing activities together with the necessary erosion and sedimentation control measures planned for a project. This type of schedule guides the contractor on work sequencing so serious erosion and sedimentation problems can be avoided.

The EPSC plan must indicate for all the scheduled work, how the proposed erosion/sediment control BMPs will divert flows, limit runoff from exposed areas, stabilize exposed soil and filter sediment. The following activities are to be included in the schedule, if applicable:

- Clearing and grubbing for perimeter controls
- Installation of perimeter controls
- Construction phasing
- Clearing and grubbing, grading, and trenching for activities other than perimeter control for each phase
- Phased Grading (including off-site activities) related to the project
- Final grading, landscaping, and stabilization for each phase
- Work on or at bridges and other water course structures
- Utility installation and removal
- Work required in any wetland
- Monitoring of rainfall
- Inspection of controls
- Installation and maintenance of permanent controls
- Installation, maintenance, and removal of temporary controls
- Disposal of waste materials generated on-site

Note that the construction activities listed above do not usually occur in a specified linear sequence, and schedules will vary due to weather and other unpredictable factors. Schedules for temporary and permanent erosion control work required in any wetlands, as are applicable for clearing and grubbing, grading, trenching, bridges, and other structures at water courses, construction, and paving are to be submitted for review by the city. Plans for erosion control on haul roads and borrow pits and plans for disposal of waste materials should also be submitted. The contractor may submit the EPSC plan from the project plans if it is correct for the proposed stage of construction, or prepare a modified version, proposing methods, materials, and procedures, to be used for the weather and site conditions at the time of construction, if applicable.

3.5 Developing an Erosion Prevention and Sediment Control Plan

Following are recommended steps and check lists to use in the development and implementation of an acceptable Erosion Prevention and Sediment Control plan. This information will provide the necessary tools to gain the City's approval and reduce overall environmental risks. After the project site has been assessed, the catch points for cuts and fills, drainage areas and drainage patterns, sensitive areas, size and location of drainage structures, and disturbances must be located on the base map. Approximate final grades and any known problems such as highly erodible soils or unstable slopes are also be noted. A sample EPSC Plan and details can be found in Appendix A.

Step 1: Identify Potential Issues

- Federal and State Environmental Regulations
- Public Agencies
- Environmental interest groups
- Public opinion

Step 2: Goals and Objectives

- Meet all regulations
- Enhance the environment
- Higher emphasis on stabilizing steep slopes (2:1 or greater)
- Reduce short- and long-term erosion
- Reduce or eliminate irrigation costs
- Maximize use of on-site materials (cost-effective solutions)
- Reduce overall maintenance
- Decrease liability
- Improve aesthetics
- Minimize negative public opinion

Step 3: Erosion Study

- Sediment sources
- Review relative sources
 - Maps and aerial photos
 - Distinctive minerals
 - Alluvial
- Review regional factors
 - Temperature
 - Precipitation
 - Wind
 - Freeze/thaw
 - Snow melt
- Review watershed
 - Watershed size
 - Topography
 - Channel density
 - Soil types
 - Ground cover
 - Land use

Step 4: Selection of Erosion and Sediment Control Materials, and Housekeeping BMPs

- Effectiveness
- Environmental impacts
- Regulatory acceptability
- Material Cost
- Long-term cost (maintenance)
- Public acceptability
- Risk/liability
- Aesthetics
- Pollutants that will be used onsite during construction

Step 5: Developing the EPSC Plan (where to go)

- City of Albany Community Development and Public Works Departments
 - Regulations and ordinances
 - Prior land use
 - Adjacent and downstream uses
- NRCS/District Conservationist
 - Soils
 - Climate
 - Vegetation/habitat
 - Water management
 - Recreational potential
 - Aerial surveys
- U.S. Geological Survey
 - Topographical maps
 - Major drainage ways
- State Environmental Agencies
 - Stream surveys
 - Wildlife habitat
 - ESA
 - Wetlands
 - Sensitive areas
- Local Flood Control
 - Rainfall data
 - Storm records
 - Flood plains

Step 6: Developing the EPSC Plan (collecting data)

- Photo/video documentation
- Field survey and evaluation (existing)
 - Topography and contours
 - Existing drainage upstream and downstream
 - Identify sensitive areas
 - Soil samples
 - Soil survey (NRSC)
- Field survey and evaluation (future)
 - Topography and contour design
 - Site drainage system type and location
 - Impervious areas
- Climate and rainfall information

- Onsite rain gauges
- Meteorologists
- Airport
- Critical habitat
 - Wetlands vegetation profile
 - Mitigation/enhancement
- Revised Universal Soil Loss Equation (RUSLE)

$$A = R \times K \times LS \times C \times P$$

A = Average annual rate of erosion in tons/ acres/years

R = Rainfall factor

K = Soil erodibility factor

L = Slope length

S = Slope gradient

C = Cover

P = Conservation practice

Step 7: Lay out Pre-construction Plan & BMPs

- Adapt the plan to the resources available
- Fit the development to the existing terrain whenever possible
- Plan must be flexible
- Keep communication lines open at all times
- All reports and instructions must be clear
- Determine construction timing and sequence
- Establish primary access point (s) for construction traffic
- Lay out limits of clearing and construction activities
- Restrict all activities in sensitive areas (mark accordingly)
- Establish BMPs including sediment control at toe of disturbed area & stabilized construction entrances
- Establish Housekeeping BMPs in staging area including concrete wash, solid waste, fueling areas, material storage.
- Establish maintenance procedures for EPSC Measures

Step 8: Identify Measures During Construction

- Install additional base measures as site clearing/disturbances occur, including stockpiles and slope contours
- Determine if construction may occur during wet weather season (October 1st – April 30th)
- Establish and schedule wet weather season work to minimize exposed soils
- Continue to establish maintenance procedures for erosion control measures

Step 9: Post Construction Measures

- Establish ground cover or permanent landscaping prior to removing base measures

Step 10: Plans and Specifications (Sample EPSC Plan - Appendix A)

- Project description
- Construction notes (shown on Appendix A)
- Names of existing roads, waterways, and drainage features
- Boundaries of environmentally sensitive areas such as wetlands

- Rights-of-way and easements
- Statement of existing conditions to include highly erodible areas (steep slopes)
- Existing and proposed contour lines
- Run-off calculations
- Calculations of desired performance standards
- Description of erosion control treatment areas
- Detailed grass establishment instructions
- Detail for each BMP used
- Wind erosion control during/following construction

Step 11: Operations and Maintenance

- Guidelines
- Maintenance instructions
 - Provide operating procedures during/after storm events
- Standards of performance
- Periodic inspection reports w/supported pictures
- Vegetation criteria
- Monitoring
 - Establish procedures for monitoring performance
 - Provide adjustment to mitigation measures as needed
- Monitoring and maintenance plan
- Maps
 - Project boundaries
 - Adjacent areas
 - Existing and final topographic features
 - Drainage areas
 - Location of existing problems
 - Location of potential problems
 - Location and extent of BMPs

3.6 Internet Access Sites

Oregon Seed Certification Service <https://seedcert.oregonstate.edu/>

Natural Resource Conservation Service www.or.nrcs.usda.gov

International Erosion Control Association <http://www.ieca.org>

Pacific Northwest Chapter IECA <https://ieca.org/PNW>

West Coast Weather Observations <https://www.weather.gov/wrh/>

Oregon Division of State Lands (DSL) <https://www.oregon.gov/dsl/Pages/index.aspx>

Oregon Department of Fish and Wildlife (DFW) <http://www.dfw.state.or.us/>

Oregon Department of Environmental Quality (DEQ) <http://www.oregon.gov/deq/wq/>

Oregon Department of Agriculture (ODA) <https://www.oregon.gov/oda/Pages/default.aspx>

CHAPTER 4: EROSION PREVENTION AND SEDIMENT CONTROL BEST MANAGEMENT PRACTICES

This chapter presents best management practices (BMP) for erosion prevention and sediment control. Information such as advantages, disadvantages, design, inspection, and maintenance requirements for each BMP are also included and should help the designer choose the most appropriate measure or control. In order to maximize the overall benefits of any BMP selection and location, planners and designers must have a thorough understanding of the site characteristics. In addition, preconstruction meetings provide a means of opening lines of communication between all individuals affected by the construction, either directly or indirectly.

The details of installation can and should vary in the field depending on the site conditions. Field variations for each type of BMP are encouraged. The substitution of other cost-effective products or methods that provide substantially equivalent or superior performance is allowed if approved by the city.

As implied by their name, BMPs are stormwater management measures and controls that are commonly recognized and accepted practices. Table 4-1 represents ratings for basic applications of commonly used erosion and sediment control BMPs. Tables 4-2 through 4-4 are matrices presenting recommended minimum erosion control measures for various sites and construction types. Additional measures may be required based on specific site conditions. Table 4-2 is a matrix summarizing recommended erosion controls for single family residential and duplex construction activities on single lots of record. Table 4-3 summarizes recommended erosion control measures for larger construction sites including commercial, industrial, and subdivision development and construction. Table 4-4 is a matrix presenting recommended erosion controls for small, linear utilities construction and ditches/swales.

Each erosion control measure presented in the matrices is presented in further detail with design, construction, and maintenance criteria in the following sections of this chapter.

Table 4-1 Matrix of Temporary and Permanent Erosion Control Best Management Practices and Estimated Effectiveness Ratings: E = Excellent, M = Moderate, P = Poor

BMP APPLICATION	TEMPORARY VS PERMANENT	RATING	PAGE
4.1 EROSION PREVENTION			
4.1.1 BMP 1: Preserve Natural Vegetation	P	E	28
4.1.2 BMP 2: Buffer Zone	P	E	29
4.1.3 BMP 3: Seeding Temporary/Permanent	T/P	E	30
4.1.4 BMP 4: Ground Cover	T	E	33
4.1.5 BMP 5: Hydraulic Applications	T/P	E	35
4.1.6 BMP 6: Sod	P	E	36
4.1.7 BMP 7: Matting	T	M	37
4.1.8 BMP 8: Plastic Sheeting	T	P	43
4.1.9 BMP 9: Dust Control	T	M	46

4.1.10 BMP 10: Pipe Slope Drain	T	E	46
4.1.11 BMP 11: Outlet Protection	T/P	E	50
4.1.12 BMP 12: Surface Roughening*	T	E	55
4.1.13 BMP 13: Check Dams*	T/P	M	57
4.1.14 BMP 14: Diversion Dikes and Swales	T	E	61
4.1.15 BMP 15: Grass-lined Swale	T/P	M	64
4.2 SEDIMENT CONTROL PRACTICES			
4.2.1 BMP 16: Sediment Fence	T	P	65
4.2.2 BMP 17: Bio-filter Bags	T	P	68
4.2.3 BMP 18: Sandbags	T	M	70
4.2.4 BMP 19: Filter Berm	T	M	71
4.2.5 BMP 20: Wattles	T	M	73
4.2.6 BMP 21: Compost Filter Sock	T	E	75
4.2.7 BMP 22: Sidewalk Subgrade Gravel Barrier	T	M	77
4.2.8 BMP 23: Inlet Protection	T	M	79
4.2.9 BMP 24: Dewatering	T	E	86
4.2.10 BMP 25: Sediment Trap	T	E	87
4.2.11 BMP 26: Sediment Basin	P	E	91
4.2.12 BMP 27: Flocculants and Coagulants	T	M	94
4.2.13 BMP 28: Construction Entrance	T	E	94
4.2.14 BMP 29: Tire Wash	T	M	97

- **BMPs can be used for sediment and erosion control**

**Table 4-2 Erosion Control Matrix
Single-Family, Duplex Residential, Manufactured Homes**

Base Measures	Construction Site		Stockpiles
	Slope < 2%	Slope > 2%	
1. Gravel construction entrance (BMP 28)	X	X	
2. Perimeter control at toe of disturbed area or stockpile (BMP 16-21)	X	X	X
3. Sidewalk subgrade gravel barrier (site slopes to street at < 5%) (BMP 22)	A	A	
4. Undisturbed buffer at toe of disturbed areas (site slopes < 10%) (BMP 2)	A	A	
5. Storm drain inlet protection barrier (BMP 23)	X	X	X
6. Concrete Washout Area	X	X	
Post Construction			
7. Re-establish permanent ground cover or landscape prior to removing erosion measures (BMP 4)	X	X	
8. Other Final Stabilization Measures (EPSCM 2.3.3)	X	X	

Key:

X Base measure

A Alternate to Base Measure 2

* Supplemental wet weather measures (October – April) (Seeding prior to September 1)

O Alternate supplemental wet weather measures, can be used as applicable

**Table 4-3 Erosion Control Matrix
Commercial, Subdivision and Large Site Construction**

	Site Slope							Stock-piles
	< 2%	< 10%	< 15%	< 20%	< 30%	< 50%	50%	
Base Measures								
Gravel construction entrance (BMP 16)	X	X	X	X	X	X	X	
1. Perimeter Control at toe of disturbed area (BMP 16-21)	X	X	X	X	X	X	X	X
2. Undisturbed buffer at toe of disturbed area (BMP 2)	A	A						
3. Sediment barrier installed on contours (spacing) (BMP 16-21)		X(300')	X(150')	X(100')	X(50')	X(25')	X(25')	
Temporary interceptor dikes/swales around active work areas (BMP 14)	#	#	#	#	#	#	#	
Storm drain inlet protection barrier (BMP 23)	X	X	X	X	X	X	X	X
Post Construction								
4. Reestablish permanent ground cover prior to removing erosion measures (BMP 4)	X	X	X	X	X	X	X	
5. Other Final Stabilization Measures (EPSCM 2.3.3)	X	X	X	X	X	X		

Key:

X Base measure

A Alternate to Base Measure 2

Optional base measure, can use as applicable

* Supplemental wet weather measures (October – April) (Seeding prior to September 1)

O Alternate supplemental wet weather measures, can be used as applicable

Note: If different areas of the site have considerably different slopes, the site may be divided, and erosion measures selected for each area for the appropriate columns in the matrix.

**Table 4-4 Erosion Control Matrix
Utilities Construction and Stockpiles / Ditches / Swales Protection**

	Utilities Construction		Stockpiles	Ditches /Swales
	Catch Basin drainage	Ditch Drainage		
Base Measures				
1. Perimeter Control at toe of disturbed area (BMP 16-21)				X
2. Check dams (BMP 13)		X		X
Storm drain inlet protection (BMP 23)	X		X	
Post Construction				
3. Reestablish permanent ground cover or landscape prior to removing erosion measures (BMP 4)	X	X		X
4. Other Final Stabilization Measures (EPSCM 2.3.3)	X	X		X

Key:

X Base measure

* Supplemental wet weather measure (October – April) (Seeding prior to September 1)

O Alternate wet weather measure to *

4.1 Erosion Prevention

The designer should keep in mind when laying out an erosion control plan that the purpose of the plan is to maximize erosion prevention and minimize sediment transport from disturbed ground surfaces. Erosion prevention is the most effective and inexpensive method for reducing overall environmental impacts associated with construction activities. With this in mind, timing, staging, minimizing the amount of exposed soil, and directing surface water runoff away from exposed soil are all excellent ways to minimize erosion during construction. Erosion control practices primarily involve preserving natural vegetation when possible or stabilizing exposed soils with temporary covers or permanent vegetation. Reducing the erosion associated with construction vehicle traffic is also covered in this section. Many of these techniques can reduce erosion by 80 to 95 percent compared with exposed soils. Erosion prevention BMPs include:

1. Preserve Natural Vegetation
2. Buffer Zone
3. Temporary and Permanent Seeding
4. Hydraulic Applications
5. Ground Cover
6. Sod
7. Matting
8. Plastic Sheeting
9. Dust Control

4.1.1 BMP 1: Preserve Natural Vegetation

This BMP involves preserving natural vegetation to the greatest extent possible during the construction process, and after construction where appropriate. Maintaining natural vegetation is the most effective and inexpensive form of erosion prevention control. This method is particularly important in sensitive areas such as wetlands, stream corridors, lakes, and near steep slopes. The project manager, inspector, and contractor should address and discuss preserving natural vegetation during the Pre-construction meeting. Although this is a proven BMP, it is imperative all exposed soils are covered in a timely manner.

Advantages

- Helps reduce soil erosion and runoff while beautifying an area
- Saves landscaping costs, provides areas for wildlife, and provides visual screening
- Helps maintain water temperature. Temperature moderation is especially important when detention ponds drain to salmonid-bearing streams
- Retains existing shade and cover habitat
- Conserves or increases property values

Disadvantages

- May constrict area available for construction activities
- May preserve unwanted/invasive plants

Design Criteria

- Coordinate with the Landscape Architect and Environmental Professionals assigned to the project when determining what to save and how to save it
- Vegetation can be preserved in natural clumps or as individual trees, shrubs, and vines
- Clearly establish ground disturbance limits outside the dripline of preserved trees, using orange construction safety fence or flagging if approved prior to any ground disturbing work
- Protect vegetation from:

- Construction equipment injury above or below the ground level. Injury occurs from scarring, cutting roots, or compaction
- Grade changes, which affect the plants' ability to obtain air, water, or minerals
- Terracing the area around the plant, or leaving the plants on an undisturbed mound can increase the plants' survival chances
 - Root exposure can lead to drying, freeze damage, and potentially wind-throw
 - Raising the grade as little as six inches can retard the normal exchange of air and gases
 - Damage caused by excavations for tile, water, and sewer lines

Inspection and Maintenance

- Inspect once per week on active sites, once every two weeks on in-active sites, and within 24 hours following a 0.5-inch rain event
- Repair fencing and/or flagging
- Re-cover and/or seal exposed plant roots

4.1.2 BMP 2: Buffer Zone

A buffer zone consists of an undisturbed area or strip of natural vegetation or an established suitable planting adjacent to a disturbed area that reduces erosion and runoff. The rooted vegetation holds soil, acts as a wind break, and filters runoff that may leave the site.

Advantages

- Filters Sediment
- Promotes infiltration
- Provides habitat
- Reduces velocity and quantity of runoff, dissipates energy
- Provides visual screening
- Can be used to stabilize stream banks
- Low maintenance

Disadvantages

- Requires keeping all construction equipment, debris, and soils out of the natural areas
- Extensive buffers can cover large areas of land not available for project development
- Are not adequate in areas of concentrated flows

Design Criteria

- The vegetative buffer zone shall be located along the entire length of the down slope edge of the entire disturbed area.
- The vegetation shall consist of 3- to 12-inch high grassy vegetation that uniformly covers at least 90 percent of a representative one square yard plot. No more than 10 percent of the surface area shall be comprised of woody vegetation.
- Clearly establish buffer zone limits with orange construction safety fence and signs spaced 100 feet apart prior to ground disturbing activities. Entry on the buffer zone shall be prohibited
- Vegetative buffer zone widths shall be determined in accordance with the following:
 - Minimum width shall be 10 feet for slopes less than five percent
 - An additional five feet shall be added for each degree of slope above five percent but not exceeding 10 percent. A 10 percent slope would require a 35-foot buffer zone (10' + {5' × 5'})
 - An additional eight feet shall be added for each degree of slope above six percent but not exceeding 15 percent. A 15 percent slope would require a 75-foot buffer zone (35' + {5' × 8'})

- An additional 10 feet shall be added for each degree of slope above 15 percent but not exceeding 20 percent. A 20 percent slope would require a 125-foot buffer zone ($75' + \{5' \times 10'\}$)
- Vegetative buffer zones are not an adequate control measure for slopes above 20 percent.
- Vegetative buffer zones for streams, lakes, or other waterways shall be a minimum of 100 feet wide. An incremental adjustment in accordance with the instructions above shall be added to the minimum. A 20 percent slope above a stream would require a 215-foot buffer zone.

Inspection and Maintenance

- Inspect flagging and fencing frequently and repair any rills and replace and/or add additional plants as needed.

4.1.3 **BMP 3: Seeding (Temporary/Permanent)**

A well-established vegetative cover is one of the most effective methods of reducing erosion. Vegetation should be established on construction sites as the slopes are finished, rather than waiting until all the grading is complete. Equally important and often overlooked is temporary or permanent irrigation. **Temporary or permanent seeding applications should be completed prior to September 1st of each year. Seeding after September 1st shall be reviewed on a case-by-case basis for adequate seed selection for cold weather.**

Advantages

- Eliminates splash erosion
- Traps sediment
- Promotes infiltration
- Improves appearance of the site
- Reduces runoff velocities
- Provides excellent stabilization
- Relatively inexpensive erosion control measure
- Effective for dust control

Disadvantages

- Needs sufficient time for seed to establish
- Requires mulch or other cover until vegetation is established
- May require fertilizer and lime to establish on poor soils
- Requires irrigation
- Must be removed prior to applying fill material

Design Criteria

The following discussion presents general information regarding seeding, bed preparation, mulching, and fertilizing.

Selection Criteria

Standard grass and legume seed mixes for erosion control purposes are developed by local or regional distributors for site-specific applications. Often more than one plant species is selected so at least one species will do well given the extreme seasonal fluctuations that occur in nature. Specific plant characteristics are chosen when developing an erosion control seed mix. Grass species are normally used rather than other plant species because of their fibrous root systems and quick establishment.

Seedling vigor is an important plant characteristic to consider for erosion control seeding because the goal is to have rapid establishment and a dense fibrous root system. This holds the soil in place and provides a thick canopy over the soil to break the raindrop velocity. Some grasses do well early in the season and can act as nurse or cover crops until the slower growing species can establish. Seed mixes are developed for specific climatic zones around the state to match the optimum growing conditions for each species.

One grass seed characteristic considered is the season predominant growth will occur. Grass species are often characterized as being either warm- or cool-season grasses. A warm-season grass, such as bluegrass, will have its predominant growth during the warm months of the year. Conversely, cool-season grasses, like hard fescue, have their predominant growth in the cool weather and produce seeds in the early spring. To obtain optimum establishment, a cool or warm season grass, or both, may be used depending on whether the seed is planted in the spring or fall.

Another plant characteristic of importance in erosion control is the method by which the grass develops, grows, and spreads. Grasses can be either rhizomatous, where the grass plant will send out runners that will start new growth, a bunch grass; or a sod-forming grass. Rooting depth is important and grasses are characterized as being deep, moderate, and shallow rooting for erosion control purposes. The mixture of rooting depths provides optimum support for soils and best enables the removal of water by the roots at the various zones in the soil.

Seed Purity

All seed applied shall be those specified in the project plan and must be measured by Pure Live Seed (PLS) weight. Pure live seed refers to the portion of a seed lot that is live seed of the desired kind. The purpose of measuring the application on a PLS basis is so trash and empty seeds do not confuse seeding rate calculations.

The seed lots will be tested and meet the minimum seed standards. Lots showing Oregon prohibited weeds are not approved. Seed must meet minimum viability standards. Oregon State University Extension Service keeps a listing of seed varieties certified in the OSU Extension Certified Seed Handbook. The seed variety must be approved by the OSU Seed Certification Board to be eligible for certification or meet the standards for certification.

- Temporary grass cover measures must be fully established by October 1st or other ground cover measures will have to be implemented. In order to establish an 80 percent healthy stand of grass, all seeding applications must be completed prior to September 1st.
- Apply permanent seeding when no further disturbances are planned.
- Seed should be applied immediately after seedbed preparation while the soil is loose and moist.
- Apply seed before applying straw mulch or other ground cover applications.
- Hydro mulch shall be applied with grass seed at a rate of 2,000 pounds per acre. On slopes steeper than 10 percent, hydroseed and mulch shall be applied with a bonding agent (tackifier). Application rate and methodology shall be in accordance with seed supplier recommendations.
- Dry, loose, weed-free straw used as mulch shall be applied at double the hydro mulch application requirement (4,000 pounds per acre). Anchor straw by working in by hand or with equipment (rollers, cleat tracks, etc.)
- Permanent or temporary irrigation shall be supplied especially in abnormally hot or dry weather or on adverse sites. Water application rates should be controlled to provide adequate moisture without causing runoff.

Site Preparation

- Bring the seedbed area to final grade, remove all rocks and debris, and smooth surface undulations larger than two inches.
- Divert concentrated flows away from the seeded area.
- For optimum seeding conditions preserve topsoil and stockpile material until final grades are established. Spread topsoil over new grades or;
- Conduct soil test to determine pH and nutrient content.
- Roughen the soil by harrowing, tracking, grooving, or furrowing.
- Apply amendments as needed to adjust pH to 6.0-7.5. Incorporate these amendments into the soil.
- The seedbed should be firm but not compact. The top four to six inches of soil should be loose, moist, and free of large clods and stones.
- If the seedbed has been idle long enough for the soil to become compact, the topsoil should be harrowed with a disk, spring tooth drag, spike tooth drag, or other equipment designed to condition the soil for seeding.
- Harrowing, tracking, or furrowing should be done horizontally (perpendicular to the slope) across the face of the slope, so ridges are along the slope contour.

Seeding

- Seed to soil contact is the key to good germination.
- Apply seed at the rates specified using calibrated seed spreaders, cyclone seeders, mechanical drills, or hydro seeder so the seed is applied uniformly on the site.
- Broadcast seed should be incorporated into the soil by raking or chain dragging, and then lightly compacted to provide good seed-soil contact.
- Apply mulch and tackifier or matting, as specified, over the seeded areas.
- To prevent seed from being washed away, confirm installation of all required surface water control measures.
- Double the rate of seed application when mulch and seed is applied in a single application.
- Recommended erosion control grass seed mixes are as follows. Similar mixes designed to achieve erosion control may be substituted with approval.
 1. Dwarf Grass Mix (low height, low maintenance)
 - Dwarf Perennial Ryegrass, 80 percent by weight
 - Creeping Red Fescue, 20 percent by weight
 - Application rate: 100 pounds minimum per acre
 2. Standard Height Grass Mix
 - Annual Ryegrass, 40 percent by weight
 - Turf-type Fescue, 60 percent by weight
 - Application rate: 100 pounds minimum per acre

Fertilizer

- Slow-release fertilizers are more efficient and have fewer environmental impacts.
- Areas being seeded for final landscaping may require soil tests to determine the exact type and quantity of fertilizer needed to prevent the over-application of fertilizer. Use non-phosphorus fertilizer on disturbed areas within 50 feet of water bodies and wetlands.
- The use of stockpiled topsoil or compost reduces the need for fertilizer and improves the overall soil quality.
- Provide project-specific application rates

Mulch

- Refer to Ground Cover and Matting sections of this chapter
- Straw mulch in loose condition is preferred for seeding during the wet season on slopes 3:1 or flatter.
- Straw mulch may be required during the dry season if:
 - Grass growth is expected to be slow
 - The soils are highly erodible
 - There is a water body close to the disturbed area
 - Significant precipitation is anticipated before the grass will provide effective cover
- The straw mulch shall not be moldy, caked, decayed, or of otherwise low quality
- Can be applied on top of the seed or applied with the seed during hydroseeding
- The application rate of seed per acre should be increased if seed and mulch are applied in a single application.

Hydroseed

- Refer to Hydraulic Application section (BMP 5) of this chapter
- Hydroseeding requires a mulch or green dye tracer as a visual aid during application
- On slopes steeper than 2:1, hydroseeding requires an increased rate of tackifier to be applied
- During the dry season, hydroseeding with wood fiber mulch is adequate

Inspection & Maintenance

- Inspect once per week on active sites, once every two weeks on in-active sites, and within 24 hours following a 0.5-inch rain event
- Newly seeded areas need to be inspected frequently to ensure the grass is growing
- If the seeded area is damaged due to runoff, additional BMPs may be needed. Re-seed and mulch damaged areas
- Spot seeding can be done on small areas to fill in bare spots where grass did not grow properly
- If spot seeding is ineffective, use an alternate method, such as sod or matting
- Re-seed and protect with mulch any areas affected by erosion. If the erosion is caused by concentrated runoff, fix the runoff problem and then re-seed and mat the area.

4.1.4 BMP 4: Ground Cover

Ground Cover is a protective layer of straw, compost or other suitable material applied to the soil surface. Straw mulch and/or hydro mulch are also used in conjunction with seeding of critical areas for the establishment of temporary or permanent vegetation. Ground cover provides immediate temporary protection from erosion. Mulch also enhances plant establishment by conserving moisture; holding fertilizer, seed, and topsoil in place; and moderating soil temperatures.

Advantages

- Provides immediate protection
- Conserves moisture
- Acts as a thermal layer for seed
- If used in conjunction with seed, allows seed growth through the mulch
- Protects seeding from direct heat, moisture loss, and transport due to runoff
- Used for dust control
- Compost can be tilled in later as soil additive to promote seed growth

Disadvantages

- Thick mulches can delay germination
- Can be blown or washed away if not adequately tackified
- Must be removed prior to applying fill material
- During dry months, irrigation may be needed to promote growth if using seed

Design Criteria

- Divert concentrated runoff from above mulched areas
- Refer to Table 4-5 outlines mulch type, quality, and application rate
- The following pages include specific material and application criteria
- Refer to Appendix B for *Mulch Application Rate Worksheet*

Inspection and Maintenance

- Inspect once per week on active sites, once every two weeks on in-active sites, and within 24 hours following a 0.5-inch rain event
- Maintain specified thickness of the cover
- Re-mulch and/or protect with a net or blanket any areas that experience erosion
- If the erosion problem is drainage related, fix the drainage problem and re-mulch the eroded area.
- Hydraulically treated areas shall be inspected and monitored after installation and periodically thereafter.
- Hydraulic mulches and tackifiers shall provide the necessary erosion protection until a permanent erosion-resistant cover is established. If sheet or rill erosion is evident, prompt re-application of treatments shall be necessary.
- If the hydraulic mulch or tackifiers were applied as stand-alone (without vegetation) treatments for erosion and dust control, the product longevity must match the length of time that the soil will remain bare or until revegetation occurs. Periodic inspections will ensure the intended purposes will be met.
- Areas that fail to establish cover adequate to prevent erosion shall be re-mulched as soon as such areas are identified.
- If mulched areas are damaged by concentrated runoff, the prompt implementation of additional practices and BMPs may be necessary.

Table: 4-5 Ground Cover Application

Mulch Material	Quality Standards	Application Rate Per Acre	Depth of Material	Considerations
Straw	Air dried, free from unwanted seeds & coarse materials	2-2 ½ tons or 90-120 bales	2 inches minimum uniform spread	Use where the mulching effects is to be maintained < 3 months. When chopped straw is applied, use a tackifier
Yard Debris Compost	Well composted organic matter free of metals, plastics, and other foreign matter	3-6 tons	4:1 slope - use 1 inch 3:1 slope - use 2 inches 2:1 slope - use 3 inches	Excellent soil amendment. Compost size: ¾ × 0 on 3:1 slope or less. 1½ × 0 on 2:1 slopes.

Wood or Cellulose Fiber	Dyed green, should not contain growth inhibiting factors	2,000 pounds	N/A	Apply with hydro mulcher. May need to double the rate depending on soil and slope. Use tackifier as recommended by manufacturer.
Wood Chips or Grindings	Green or air dried free of objectionable coarse materials	5-6 tons	1-3 inches depending on slope	Very durable. Apply with mulch blower, excavation equipment, or by hand. Not suitable for areas that require close mowing.
Gravel or Crushed Rock	Washed ¾-1.5inch	9 yards/1,000 feet ²	3 inches	Excellent for short slopes and where subject to foot traffic. Larger pit-run can be used on steep slopes prone to sub-surface water (springs).

4.1.5 **BMP 5: Hydraulic Application**

Hydraulic application is a mechanical method of applying erosion control materials to bare soil in order to establish erosion-resistant vegetation on disturbed areas and critical slopes. By using hydraulic equipment soil amendments, mulch, tackifying agents, Bonded Fiber Matrix (BFM), and liquid copolymers can be uniformly broadcast as homogenous slurry onto the soil. These erosion and dust control materials can often be applied in one operation.

Advantages

- Provides rapid installation with a one step process
- Generally requires less seedbed preparation. The surface soil may be left irregular with large clods, stones, or rock outcropping exposed.
- Uniformly distributes seed and mulch material
- Increases favorable conditions for quick germination and growth
- Can be used effectively on steep slopes and other areas where access is limited

Disadvantages

- Generally more expensive than broadcast or drilling seed applications
- Thick mulch applications can delay germination
- Can be blown or washed away if not adequately tackified
- Required application rates can vary significantly dependent on site preparation

Design Criteria

- Divert concentrated runoff from above treated areas
- Seed, fertilizer, mulch, tackifier, soil amendments, Bonded Fiber Matrix, and chemical stabilization can be applied in a one-step procedure
- Wood fiber mulch or wood/paper mulch should be applied at a rate of 2,000 to 2,500 pounds per acre
- Bonded Fiber Matrix (BFM) is considered a liquid blanket and can be applied on steep 1:1 slope. Application rates between 3,000 and 4,000 lbs. per acre, depending upon soil type and irregularities.

- Use hydraulic applications on slopes steeper than 4:1 that cannot receive adequate seedbed preparation and where mulch would be difficult to otherwise anchor
- On sites where other soil stabilization, seeding, and mulching practices would result in unacceptable levels of ground disturbance
- Use where site conditions, such as irregular soil surfaces, existing vegetation, and shallow soils preclude the installation of erosion mats
- If used when seeding, maintain sufficient moisture level using permanent or temporary irrigation
- On sites where straw mulch has been applied and the straw needs to be anchored using a liquid tacking agent
- On sites where dust control is desired
- If the hydraulic mulch or tackifiers were applied as stand-alone (without vegetation) treatments for erosion and dust control, the product longevity must match the length of time the soil will remain bare or until re-vegetation occurs
- Refer to Appendix B Hydraulic Application Tables for seed and mulch

Inspection and Maintenance

- Inspect once per week on active sites, once every two weeks on in-active sites, and within 24 hours following a 0.5-inch rain event
- Re-mulch and/or protect with an erosion control matting any areas that experience erosion. If the erosion problem is drainage related, fix the drainage problem then make necessary repairs.
- Hydraulic mulches and tackifiers shall provide the necessary erosion protection until permanent erosion-resistant cover is established. If sheet or rill erosion is evident then prompt re-application of treatments shall be necessary..
- Areas that fail to establish 80 percent healthy stand of grass cover to prevent erosion shall be properly covered using one of the selected application.

4.1.6 BMP 6: Sod

Establishes permanent turf for immediate erosion protection and stabilizes drainage ways.

Advantages

- Provides immediate, effective protection, and is aesthetically pleasing
- Provides high-density vegetation, which is superior to a recently seeded area
- Placement can occur any time soil moisture is adequate, and the ground is not frozen

Disadvantages

- Expensive
- Availability is seasonal
- Irrigation may be required if installed in summer
- Difficult to mow if installed on slopes steeper than 3:1
- Installations in grassed waterways may roll up if not anchored or drained properly
- Time necessary for root establishment may be lengthy

Design Criteria

- Use sod as a short- or long-term cover
- Use around inlets located off roadways
- Use sod that is generally weed free, has uniform thickness (approximately 1 inch thick), and dense root mat for mechanical strength.

- Generally inappropriate for bioswales. Sod can be used for lining ditches or waterways carrying intermittent flows.
- The following steps are general recommendations for sod installation:
 1. Shape and smooth the surface to final grade in accordance with the approved grading plan
 2. Fertilize as per supplier's recommendations. Non-phosphorous fertilizer is required near water bodies and wetlands
 3. Work lime and fertilizer into soil one to two inches deep and smooth the surface
 4. Lay sod strips perpendicular to the direction of water flow, beginning at the lowest area to be sodded. Wedge strips securely into place and square the ends of each strip to provide for a close, tight fit. Stagger joints at least 12 inches. Staple sod onto 3:1 and steeper slopes.
 - Roll the sodded area and irrigate
 - Not for use in high velocity channels/ditches

Inspection and Maintenance

- Inspect once per week on active sites, once every two weeks on in-active sites, and within 24 hours following a 0.5-inch rain event
- Inspect sod area frequently for soil moisture content and root establishment
- Re-tack, re-sod or re-seed as necessary
- If it is impossible to establish a healthy ground cover due to frequent saturation, instability, or some other cause; remove the sod, seed the area with an appropriate mix, and protect with matting

4.1.7 BMP 7: Matting

There are numerous erosion control products available that can be described in various ways, such as matting, blankets, fabric, and nets. We will call them all matting. A wide range of materials and combination of materials are used to produce matting including, but not limited to straw, jute, wood fiber, coir (coconut fiber), plastic netting, and Bonded Fiber Matrix. The selection of matting materials for a site can make a significant difference in the effectiveness of the BMP.

When selecting matting consider these questions:

1. How long will the matting be required to provide protection?
2. How steep is the slope?
3. What is the soil type?
4. What is the shear stress on the channel bottom?

Advantages

- Immediate cushioning against splash erosion from raindrop impact
- Does not generate high-velocity runoff and, therefore, offers temporary slope protection, which is superior to plastic sheeting
- Captures a great deal of sediment due to its open, porous structure
- Usually easy to install
- Provides long-term protection, based on matting selection

Disadvantages

- Correct installation is critical to the effectiveness of these products. Good ground contact during installation prevents runoff concentrating under the blanket and causing significant erosion (tenting).
- Soil surface must be graded smooth with no surface irregularities
- Limited protection capabilities when used as flexible channel liner

Design Criteria

- Generally used on slopes 3:1 and steeper
- Surface must be graded smooth
- Remove all debris and undulations larger than two inches in any dimension
- Apply seed and fertilizer prior to matting
- Install so matting is in complete contact with soil surface
- See Table 4-6 for matting application and staple pattern
- Organic matting materials (excelsior, jute, and coir) biodegrade and are useful for applications requiring stabilization for up to three months. Use organic blankets, which retain moisture and provide organic matter to the soil, for slope protection, and short-term waterway protection and to improve the speed and success of re-vegetation.
- Excelsior brand (aspen wood fiber), woven straw, and coir (coconut fiber) blankets may be installed without mulch because they provide complete surface protection.
- Synthetic mats are made from non-biodegradable material and will remain in place for years (some photodegradation does occur). Use purely synthetic blankets for long-term stabilization of waterways.
 - Turf Reinforcement Mats (TRM) are made from polymer netting or monofilaments formed into a Synthetic 3-D mat. TRMs protect seed and increase germination and also act as part of the root structure, giving the turf higher strength.
 - Erosion Control and Revegetation Mats (ECRM), composed of heat-fused monofilaments or monofilaments stitched between netting act as permanent mulch. ECRM allow growth through the mat.
- Channel or swale applications:
 - Lengthwise overlap: Minimum 12 inches
- Crosswise overlap: Minimum six inches
- Avoid joining material in center of ditch or swale
- Slope application:
 - Lengthwise overlap: Minimum 6 inches
 - Crosswise overlap: Minimum 6 inches
 - At top of slope, entrench material in a six-inch × six-inch trench and staple at 12-inch intervals
 - At bottom of slope, extend mat two feet beyond the toe of the slope, turn material under four inches, and staple at 12 inch intervals
 - On 4:1 slopes, rolls can be placed in horizontal strips
 - Mats must be stapled in place as they are installed down the slope face every four feet until the bottom is reached. This keeps the blanket in relaxed position, eliminating the potential for under-rilling.

Inspection and Maintenance

- Inspect once per week on active sites, once every two weeks on in-active sites, and within 24 hours following a 0.5-inch rain event
- Repair any damaged areas of the net or blanket and staple into the ground any areas not in close contact with the ground surface
- If erosion occurs, repair and protect the eroded area

Table 4-6 Matting Specifications

Matting Type	Slope/ Channel Application	Netting Type
Straw	3:1 or less	Type 1 - Photo degradable polypropylene top/bottom Type 2 – 100 percent Biodegradable (used near sensitive habitat areas)
Straw/Coconut	2:1 or less	Type 1 – Photo degradable polypropylene top/bottom Type 2 – 100 percent Biodegradable (used near sensitive habitat areas)
Coconut	1:1 or less Low flow channels	Type 1 – Photo degradable polypropylene top/bottom Type 2 – 100 percent Biodegradable (used near sensitive habitat areas)
Jute	3:1 or less Short, 2:1 slope	100 percent Biodegradable
Excelsior	2:1 or less Low flow channel	Photo degradable extruded plastic mesh top/bottom
Coir fabric	1:1 or less 8-10 fps channel	Type 1 – 1-inch grid 100 percent Biodegradable (4–10-year life) Type 2 – ½-inch grid 100 percent Biodegradable (4–10-year life) Type 3 – ¼-inch grid 100 percent Biodegradable (4–10-year life)
TRM	High flow Channels 8-20 fps	Three-dimensional synthetic polyolefin fibers mechanically bonded between two nets.

Diagram 4.1.7a
MATTING SLOPE INSTALLATION

SHALLOW SLOPES 4:1 OR LESS

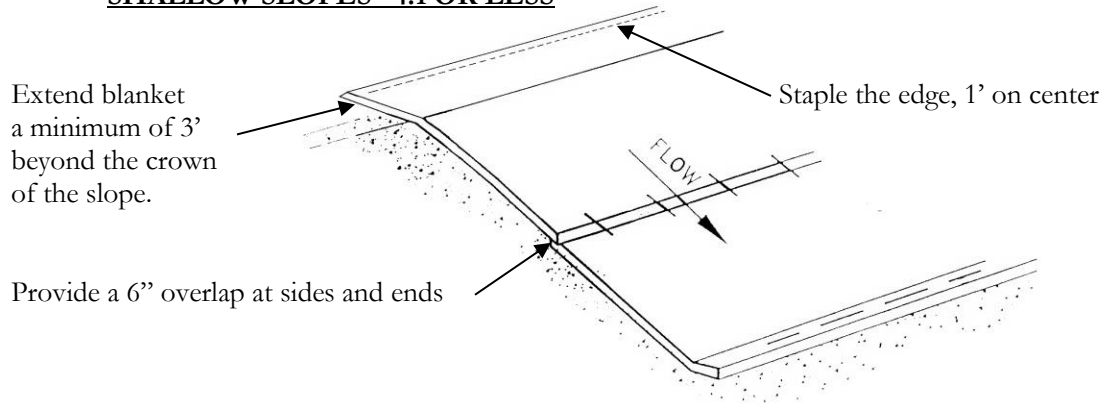

MODERATE SLOPES 3:1

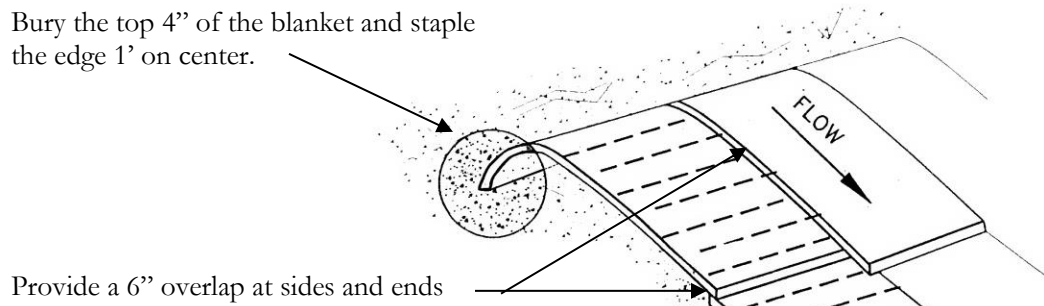

STEEP SLOPES 2:1 OR GREATER

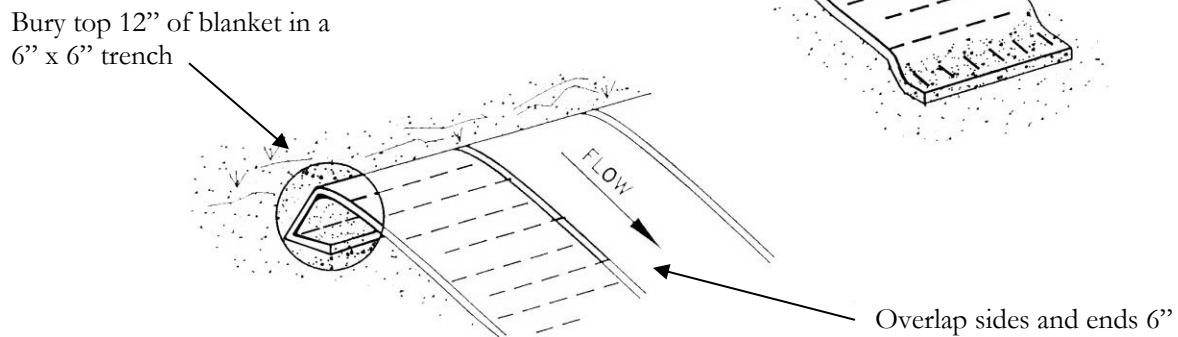

NOTES:

1. On shallow slopes, blankets may be applied across the slope.
2. All Blanket staples required as per table in Diagram 4.1.7c

Diagram 4.1.7b
MATTING CHANNEL INSTALLATION

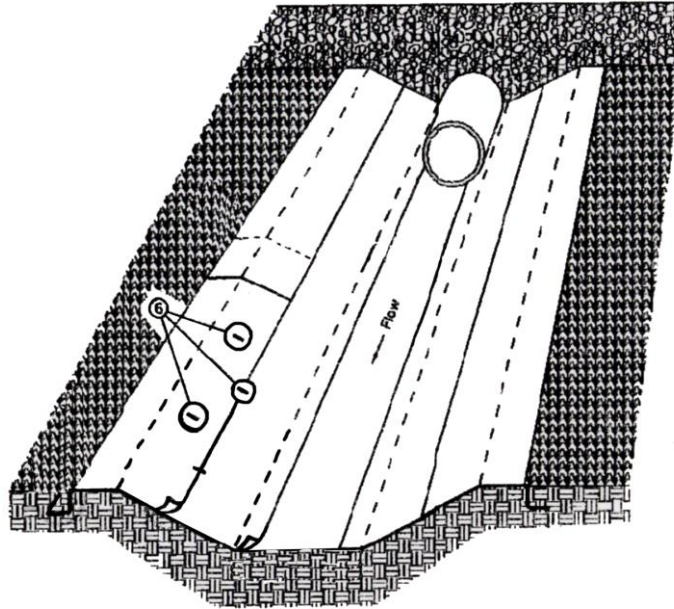

NOTES:

1. Information provided is the minimum protection required. Manufacturer's instructions shall be used where they are more stringent than those provided here.
2. Install mat parallel to flow, centered in channel. For culvert outfalls, place the mat under the culvert or rip rap the outlet over the mat.
3. Overlap sides and ends of blankets a minimum of 12 inches.
4. Refer to Diagram 4.1.7a for channel slope applications.
5. Refer to Diagram 4.1.7c for staple requirements.
6. The length of staples shall be determined by soil type. Cohesive soils shall use a minimum 6" staple. Non-cohesive soils shall use 8" – 12" staples.

Diagram 4.1.7c
MATTING STAPLE REQUIREMENTS

STAPLE PATTERN

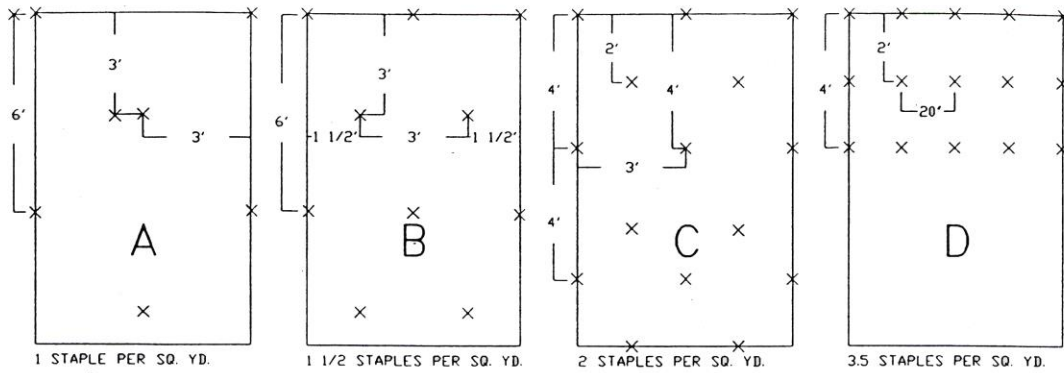

LENGTH AND SLOPE TABLE

300	B	C	C	C	C	D
275						
250						
225						
200						
175						
150		B				
125						
100	A					
75		A	B			
50				B		
25						
ft						
	4:1	3:1	2:1	1:1	LOW FLOW CHANNEL	MED/HIGH FLOW CHANNEL

*MINIMUM STAPLE PATTERN GUIDE AND RECOMMENDATION FOR SLOPE AND CHANNEL APPLICATION.

Diagram 4.1.7d
COMPOST STORMWATER BLANKET

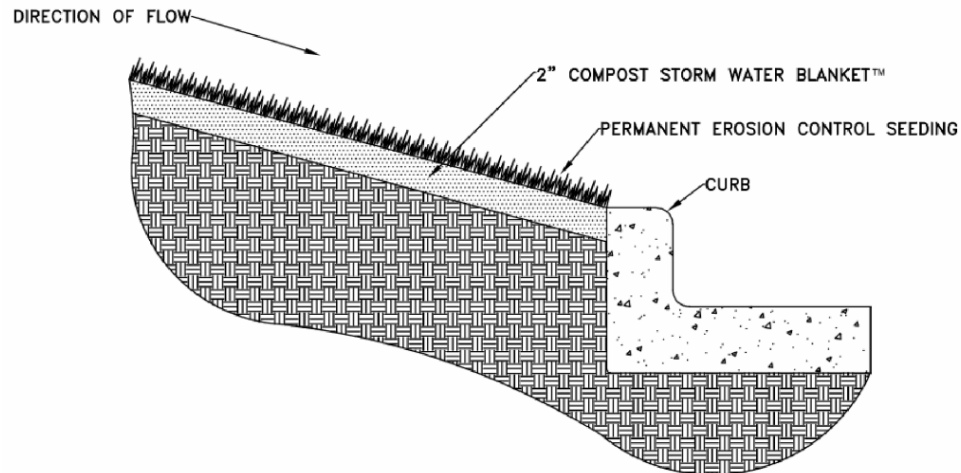

COMPOST STORMWATER BLANKET

NOTES:

1. COMPOST BLANKET WILL BE MADE OF YARD DEBRIS WELL COMPOSTED ORGANIC MATTER, FREE OF METALS, PLASTICS, AND OTHER FOREIGN MATTER.
2. APPLICATION RATE PER ACRE WILL BE 3-6 TONS.
3. DEPTH OF MATERIAL WILL BE NO LESS THAN 1 INCH 4:1 SLOPES, 2 INCH 3:1 SLOPES, 3 INCH 2:1 SLOPES.
4. COMPOST SIZE WILL BE WILL BE A MINIMUM ¾" X 0 ON 3:1 SLOPES OR LESS, 1 ½" X 0 COARSE GRADE ON 2:1 SLOPES.

4.1.8 BMP 8: Plastic Sheeting

Provides immediate protection to slopes and stockpiles. Plastic sheeting has been known to transfer erosion problems because water will sheet flow off the plastic at high velocity. This is usually attributable to poor application, installation, and maintenance. Use alternatives to plastic covering whenever possible.

Advantages

- Provides immediate, short-term erosion protection to slopes prone to erosion and to stockpiles.
- Fairly quick and easy to install.

Disadvantages

- Plastic sheeting may concentrate sunrays and burn the vegetation beneath it
- Material generates high velocity runoff
- Plastic breaks down quickly when exposed to ultraviolet radiation
- Plastic, when it is not completely removed, can clog drainage system inlets and outlets
- If not properly anchored, wind may transport plastic onto roadways and create traffic hazard
- Not effective for preventing illegal discharge

Design Criteria

- Do not use plastic covering upslope of areas such as steep and/or unstable slopes that might be adversely affected by concentrated runoff
- When possible, install an interceptor dike at the top of the plastic to divert flows away from the plastic
- Toe-in the top of the sheeting in a 6 inch × 6-inch trench backfilled with compacted native material
- Install a gravel berm, riprap, or other suitable protection at the toe of slope in order to dissipate runoff velocity
- Anchor the plastic using sandbags or other suitable tethered anchoring system spaced on a 10-foot grid spacing
- Overlap seams one to two feet, tape, roll, and stake the seams and then weigh down the entire length

Inspection and Maintenance

- Inspect once per week on active sites, once every two weeks on in-active sites, and within 24 hours following a 0.5-inch rain event
- Replace torn sheets and repair open seams
- Completely remove and replace plastic when it begins to deteriorate
- Completely remove all plastic once it is no longer needed
- Check anchoring system and repair or add anchors

Diagram 4.1.8
PLASTIC SHEETING INSTALLATION

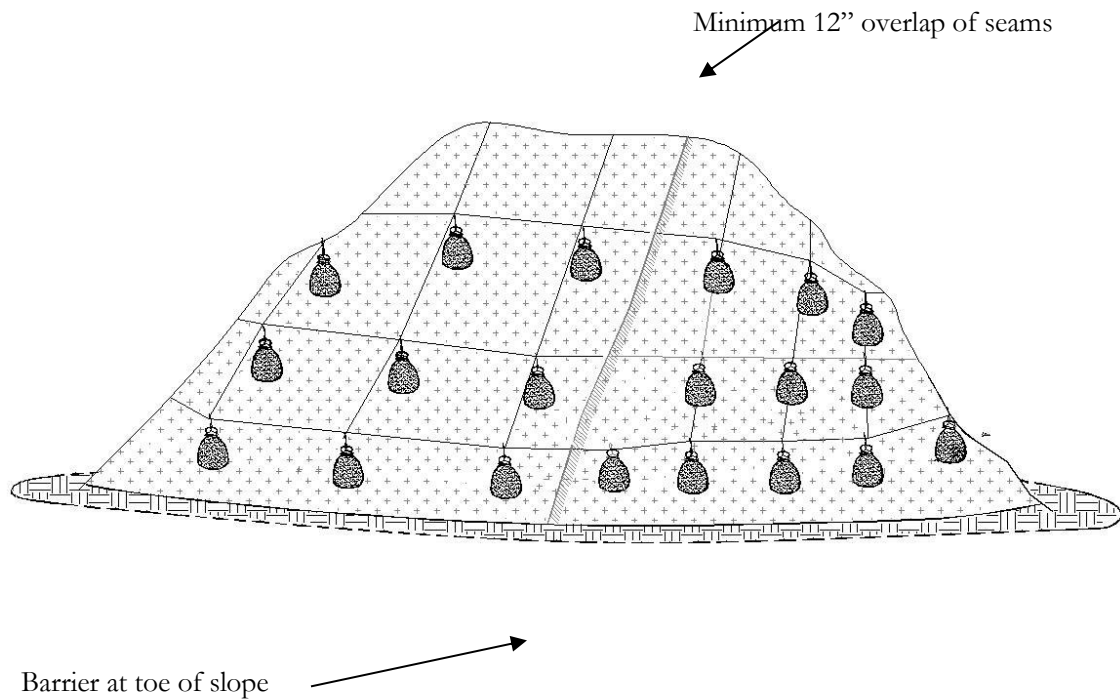

NOTES:

1. Minimum 12" overlap of all seams is required
2. A barrier is required to be installed at the toe of the stock pile
3. Covering shall be maintained tightly in place by using sandbags or tires on ropes with a maximum ten-foot grid spacing in all directions

4.1.9 **BMP 9: Dust Control**

Preventative measures to minimize the wind transport of soil, prevent traffic hazards and reduce sediment transported by wind and deposited in water resources.

Advantages

- Reduces movement of soil to offsite areas
- Increases visibility

Disadvantages

- Over watering may cause erosion
- Most methods require immediate reapplication if disturbed
- Too little watering fails to control dust

Design Criteria

- Installing construction entrances and stabilizing construction haul roads with crushed rock
- Designer can provide project-specific dust control specifications for the contractor to apply.

Measures include:

- Seeding
 - Mulching
 - Matting
 - Water
 - Tackifier
 - Chemical Soil Stabilizers
- Schedule construction operations so the least amount of project area is disturbed at one time
 - Install temporary or permanent surface stabilization measures immediately after completing land grading

Inspection and Maintenance

- Maintain dust control measures through dry weather periods until all disturbed areas have been stabilized
- Immediately re-stabilize areas disturbed by contractor's operations or other activities (wind, water, vandalism, etc.)

4.1.10 **BMP 10: Pipe Slope Drain**

A pipe slope drain is created by extending a pipe from the top to the bottom of a cut or fill and discharging into a stabilized watercourse, sediment trapping device, or onto a stabilized area. The pipe slope drain carries concentrated runoff down steep slopes without causing gullies, erosion, or saturation of slide-prone soils.

Advantages

- Effective method of conveying water down steep slopes
- Reduces or eliminates erosion
- Easy installation and little maintenance

Disadvantages

- Drain can be under-designed or incorrectly located

- Area cleared for drain installation requires stabilization to prevent erosion occurring under the pipe
- Outfall systems constructed of pipe segments, which are banded and/or gasketed together, could develop leaks causing erosion and failure of the system. Failures on erodible or steep slopes can cause downstream sedimentation or even mudflows
- Adjustment of pipe lengths is necessary as cut and fill slopes are extended

Design Criteria

- Capacity – Peak runoff from a 10-year storm. Inlet control is a critical factor when sizing pipes. Unless they are individually designed, size drains according to Table 4-7
- On any slope where a large amount of flow must be collected and conveyed to avoid erosion
- Areas where clean water should be kept separate from sediment-laden water
- If a permanent measure is needed it must be designed as part of the roadway drainage facilities

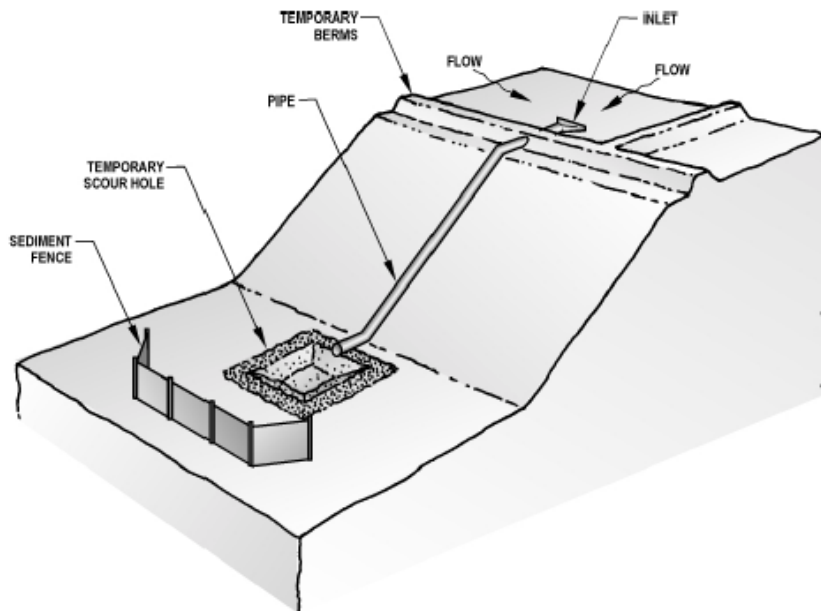

Table 4-7 Slope Drain Sizes

Contributing Drainage Area (Maximum)	Pipe Diameter
0.50 acre	12 inches
0.75 acre	15 inches
1.00 acre	18 inches

- Consider using continuously fused, welded, or flange-bolted mechanical joint systems with proper anchoring or HDPP (high-density polyethylene pipe) for outfalls on steep slopes
- Show the entrance sloped toward the pipe inlet
- At the inlet, show interceptor dikes that are at least 12 inches higher at all points than the top of the inlet pipe and placed to direct water into the pipe
- If the pipe slope drain will convey sediment-laden runoff, direct the runoff to a sediment retention facility
- If the runoff is not from a disturbed area or is conveyed from a sediment trap or pond, convey the runoff to a stabilized discharge point
- Energy Dissipation – Scour holes or riprap-lined stilling basins prevent most scour problems at outfalls
- Consider site conditions to determine if a more complex energy dissipater may be required
- The special provisions and typical notes should include the following installation directions:
 - Minimize disturbance during installation. In some circumstances this requires HDPP installed by hand
 - Slope anchor details
 - Immediately stabilize any area disturbed during installation or maintenance
 - Securely connect the standard flared end section at the entrance to the slope drain, using watertight connecting bands
- Pipe shall be staked securely to prevent movement
 - Securely fasten together the slope drain sections with gasketed watertight fittings, and securely anchor the sections into the soil
 - Stabilize the area below the outlet following the energy dissipater

Inspection & Maintenance

- Inspect once per week on active sites, once every two weeks on in-active sites, and within 24 hours following a 0.5-inch rain event
- Adjust lengths of pipe when cut and fill slopes are extended
- Regularly check the inlet and outlet points, especially following heavy rains. If there are signs of undercutting or water is going around the point of entry, reinforce the head wall with compacted earth or sand bags
- Regularly check at connection points for signs of erosion. Tighten fittings and repair erosion as needed
- Immediately repair and install appropriate protection if erosion occurs at the outlet

Diagram 4.1.10
PIPE SLOPE DRAIN

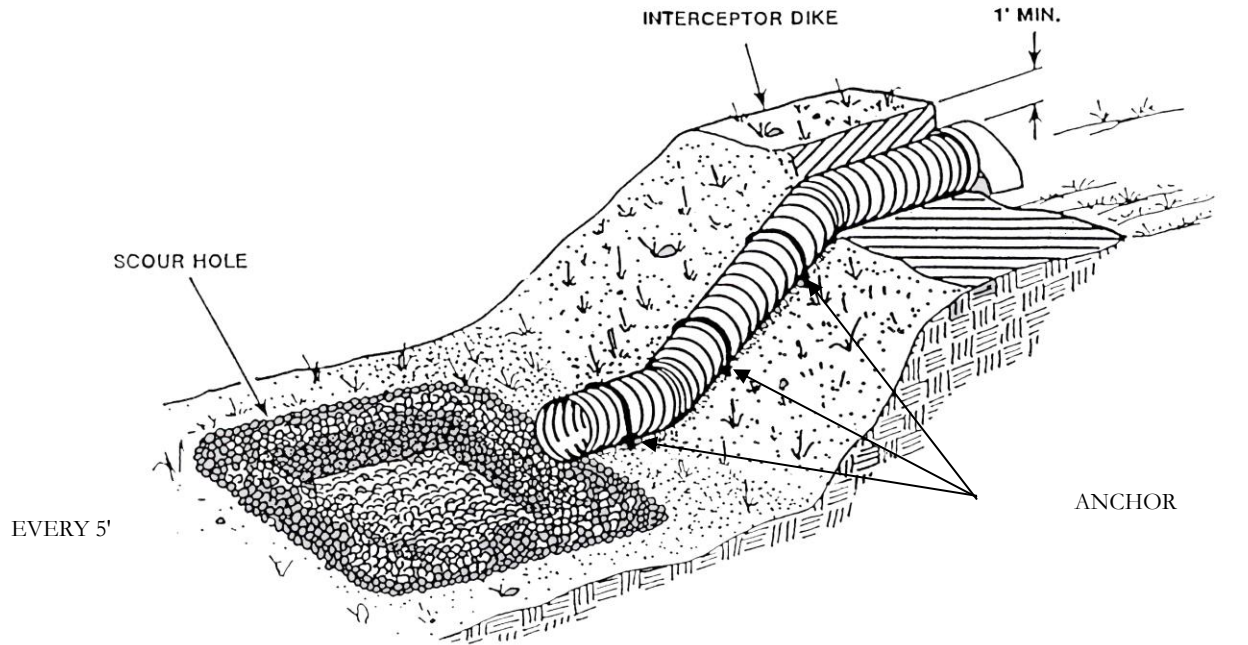

SEDIMENT FENCE REQUIRED WHERE DISCHARGING
 SEDIMENT LADEN WATER
 OR TEE

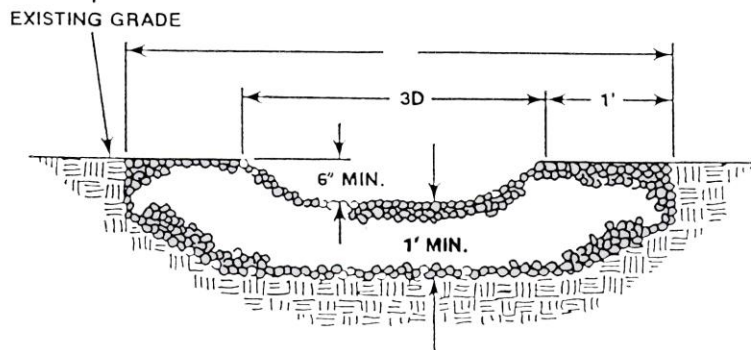
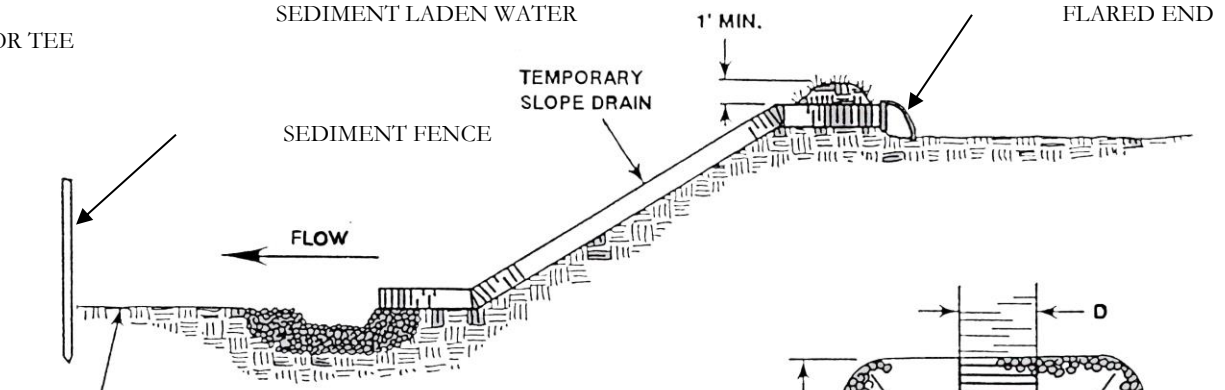

SCOUR HOLE DETAIL - FRONT VIEW

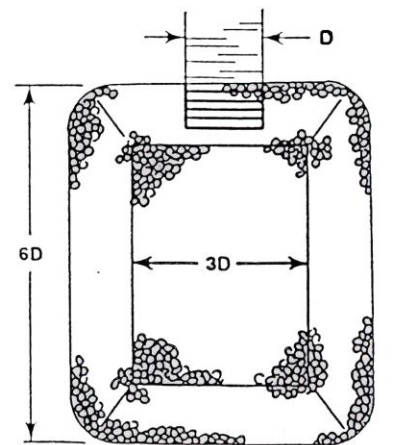

SCOUR HOLE DETAIL TOP VIEW

4.1.11 **BMP 11: Outlet Protection**

Outlet protection reduces the speed of concentrated flow, thereby preventing scour at conveyance outlets. By dissipating energy, outlet protection lowers the potential for downstream erosion. Outlet protection includes rip-rap-lined basins, concrete aprons, and settling basins. Outlet protection prevents scour at stormwater outlets and minimizes the potential for downstream erosion.

Advantages

- Many techniques are effective and relatively inexpensive and easy to install
- Removes sediment and reduces velocity

Disadvantages

- Can be unsightly
- May be difficult to remove sediment without removing and replacing the structure itself
- Rock outlets with high velocity flows may require frequent maintenance

Design Criteria

At a minimum, all outfalls shall be provided with a rock splash pad (see Diagram 4.2.4), except as specified below and in Table 4-8:

1. For outfalls with a velocity at design flow greater than 10 fps, gabion dissipater or engineered energy dissipater shall be required. Note that a design engineered to specific site conditions is required.
2. Engineered energy dissipaters, including stilling basins, drop pools, hydraulic jump basins, baffled aprons, and bucket aprons, are required for outfalls with velocity at design flow greater than 20 fps. These are to be designed using published or commonly known techniques found in such references as *Hydraulic Design of Energy Dissipaters for Culverts and Channels*, published by the Federal Highway Administration of the United States Department of Transportation; *Open Channel Flow*, by V. T. Chow; *Hydraulic Design of Stilling Basins and Energy Dissipaters, EM 25*, Bureau of Reclamation (1978); and other publications, such as those prepared by the Soil Conservation Service (now Natural Resource Conservation Service). Alternate mechanisms, such as bubble-up structures (which will eventually drain) and structures fitted with reinforced concrete posts, may require an approved adjustment and must be designed using sound hydraulic principles and considering constructability and ease of maintenance.

Table 4–8 Rock Protection at Outfalls

Discharge Velocity at design Flow (fps)		REQUIRED PROTECTION				
Greater than	Less than or equal to	Minimum Dimensions				
		Type	Thickness	Width	Length	Height
0	5	Rock lining	1 foot	Diameter + 6 feet	Greater of: 8 feet or 4x diameter	Crown + 1 foot
5	10	Riprap (2)	2 feet	Greater of: Diameter + 6 feet or 3x diameter	Greater of: 12 feet or 4x diameter	Crown + 1 foot
10	20	Gabion Outfall	As required	As required	As required	Crown + 1 foot
20	N/A	Engineered energy dissipater required				

- Rock lining shall be quarry spalls with gradation as follows:
 - Passing 8-inch square sieve: 100%
 - Passing 3-inch square sieve: 40 to 60% maximum
 - Passing 3/4-inch square sieve: 0 to 10% maximum
- Riprap shall be reasonably well graded with gradation as follows:
 - Maximum stone size: 24 inches (nominal diameter)
 - Median stone size: 16 inches
 - Minimum stone size: 4 inches

Note: Riprap sizing governed by side slopes on outlet channel is assumed to be approximately 3: 1.

- **Other Recommended Outfall Features** – Mechanisms which reduce velocity prior to discharge from an outfall are encouraged. Some of these are drop manholes and rapid expansion into pipes of much larger size. New pipe outfalls can provide an opportunity for low-cost fish habitat improvements. For example, an alcove of low-velocity water can be created by constructing the pipe outfall and associated energy dissipater back from the stream edge and digging a channel, over-widened to the upstream side, from the outfall to the stream. Overwintering juvenile and migrating adult salmonids may use the alcove as shelter during high flows.

Inspection and Maintenance

- Inspect once per week on active sites, once every two weeks on in-active sites, and within 24 hours following a 0.5-inch rain event
- If there is scour at the outlet, protect the eroded area by increasing the size of the energy dissipater facility
- Remove accumulated sediment frequently

Diagram 4.1.11
OUTLET PROTECTION

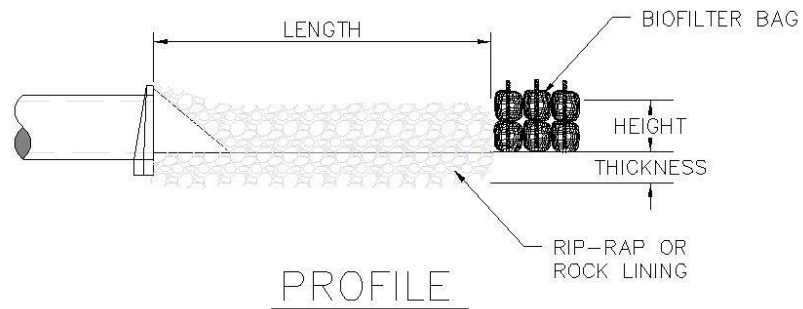
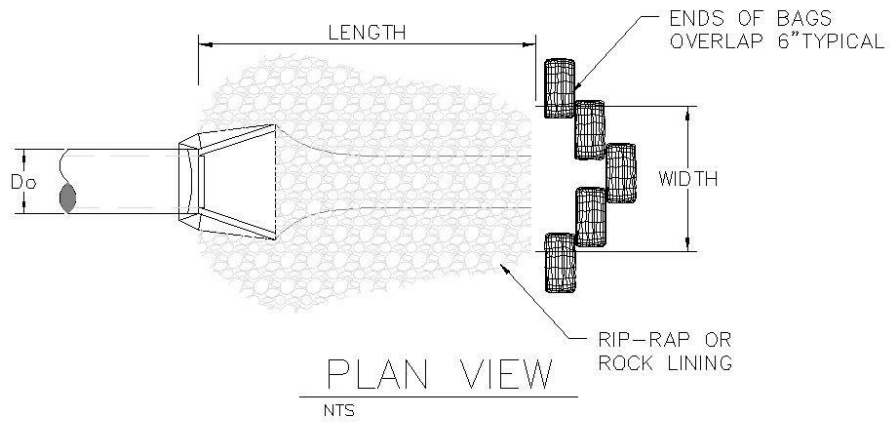

NOTE:

1. BIO BAGS ONLY REQUIRED WHEN DISCHARGING SEDIMENT LADEN WATER.
2. STAKING OF BAGS REQUIRED WITH EITHER METHOD USING (2) 1"x 2" WOOD STAKES OR APPROVED EQUAL PER BAG.

4.1.12 **BMP 12: Surface Roughening**

Leaving the slopes in a roughened condition after clearing or creating a rough soil surface with horizontal depressions or grooves will trap seed and reduce runoff velocity. Roughening can be accomplished by “track walking” slopes with tracked equipment, by using a serrated wing blade attached to the side of a bulldozer, or by other agricultural equipment.

Advantages

- Grooves trap seed
- Increased vegetation establishment
- Reduces runoff velocity, increases infiltration
- Provides some instant protection from sheet erosion
- Traps soil eroded from the slopes above

Disadvantages

- Tracking with a bulldozer/heavy equipment may compact the soil
- May increase time to finish slopes
- Should not be relied on as sole means of erosion control

Design Criteria

- All slopes to be seeded
- On slopes 3:1 or less but can be used on steeper slopes in conjunction with the addition of staging sediment barriers
- Immediately seed and mulch roughened areas to obtain optimum seed germination and growth
- Height of track grousers should be 1 ½ inches or greater
- Tracking is accomplished by driving equipment up and down slope to create horizontal depressions/grooves

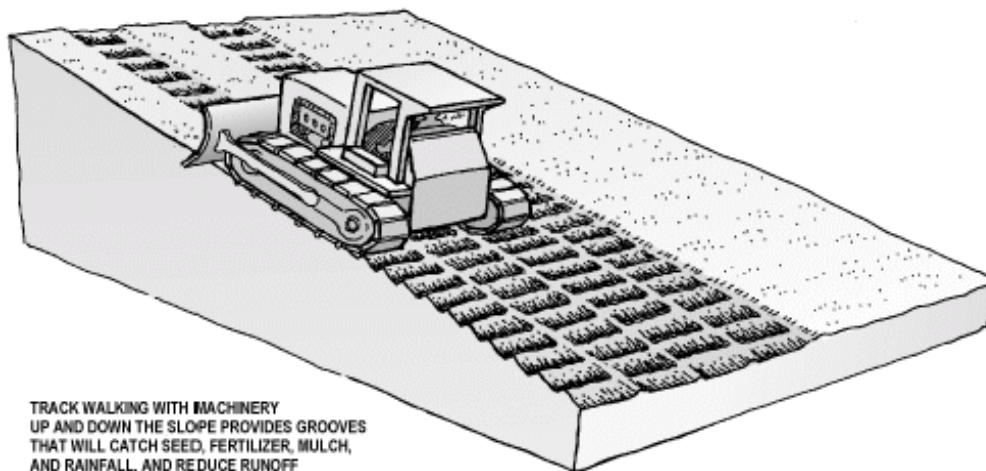

Cut Slope Roughening

- Stair-step grade or groove cut slopes that are steeper than 3:1.
- Use stair-step grading on all erodible material soft enough to be ripped with a bulldozer. Slopes consisting of soft rock with the same subsoil are particularly suited to stair-step grading.
- Make the vertical cut distance less than the horizontal distance, and slightly slope the horizontal position of the "step" in toward the vertical wall.
- Do not make individual vertical cuts more than 2 feet high in soft materials or more than 3 feet in rocky materials.
- Groove the slope using machinery to create a series of ridges and depressions that run across the slope, on the contour.

Fill Slope Roughening

- Place fill slopes with a gradient steeper than 3:1 in lifts not to exceed ½ foot, and make sure each lift is properly compacted.
- Ensure that the face of the slope consists of loose, uncompacted fill four to six inches deep.
- Use horizontal grooving along the contour or tracking to roughen the face of the slopes, if necessary.
- Apply seed, fertilizer and straw mulch, and then track or punch the mulch with a bulldozer.
- Do not blade or scrape the final slope face.

Cuts, Fills, and Graded Areas

- Make mowed slopes no steeper than 3:1
- Roughen these areas to shallow grooves by normal tilling, disking, harrowing, or use a cultipacker-seeder. Make the final pass of any such tillage on the contour.
- Excessive roughness is undesirable where mowing is planned

Inspection & Maintenance

- Inspect once per week on active sites, once every two weeks on in-active sites, and within 24 hours following a 0.5-inch rain event
- Check the seeded slopes for rills and washes. Fill these areas slightly above the original grade, then re-seed, mulch, or mat as soon as possible.

Diagram 4.1.12a
SURFACE ROUGHENING – CAT TRACKING

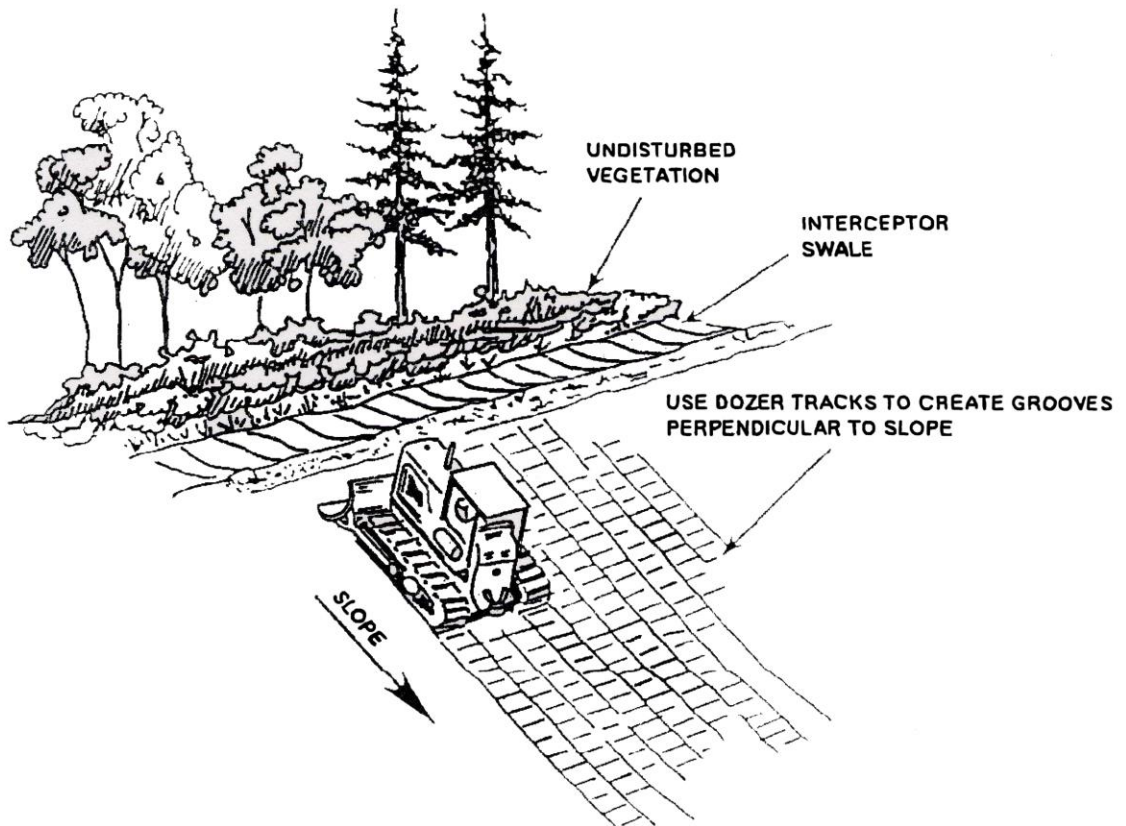
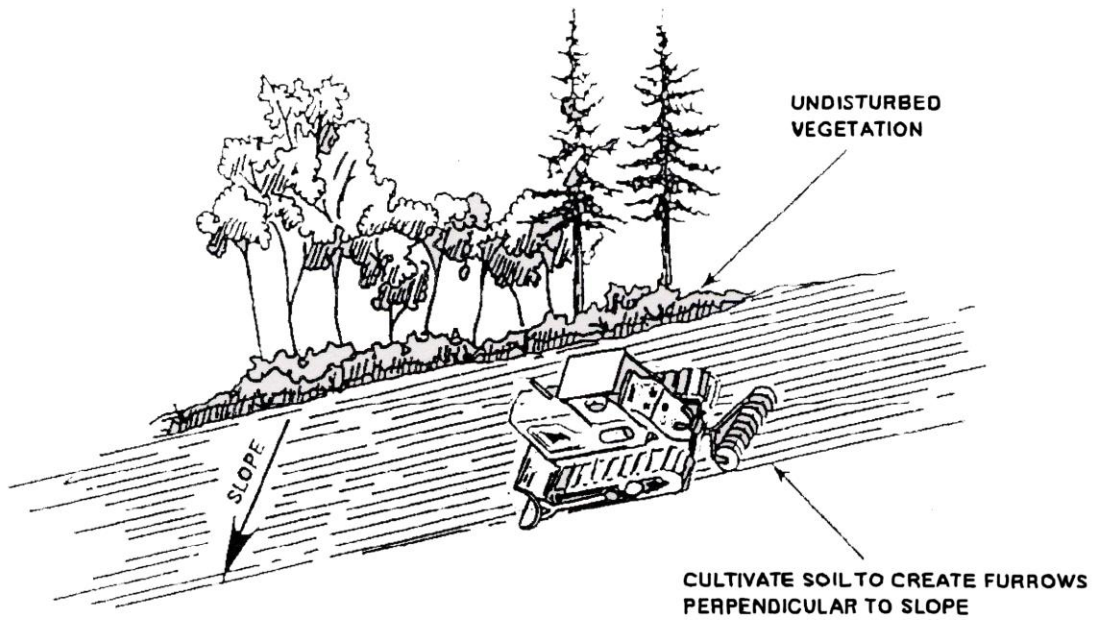
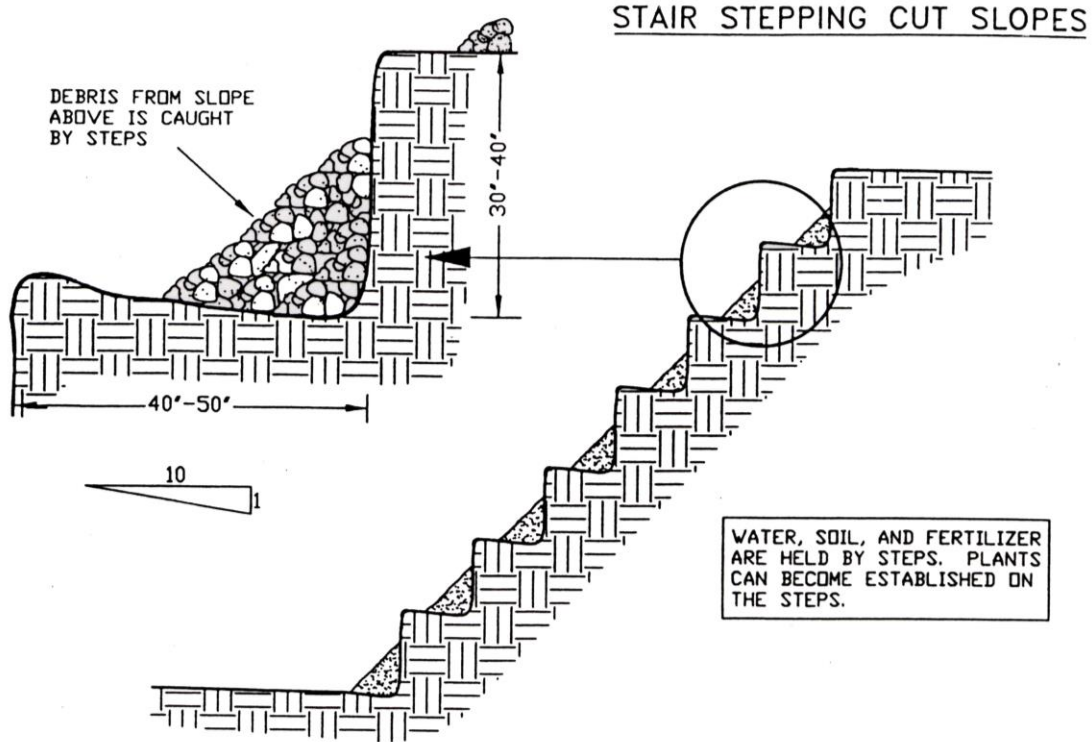
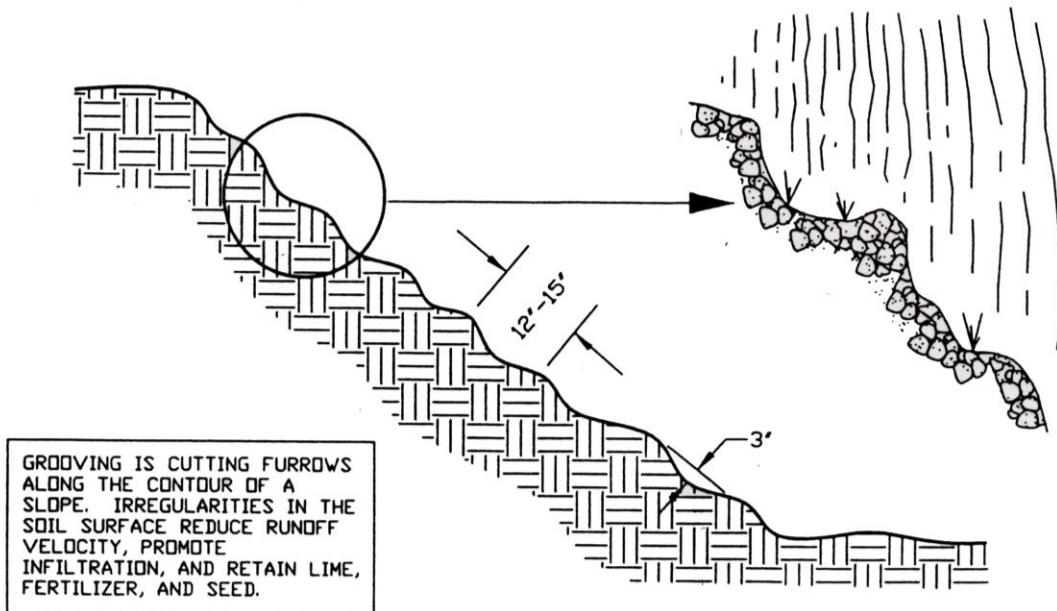

Diagram 4.1.12b

SURFACE ROUGHENING – STAIR STEPPING/GROOVING SLOPES



GROOVING SLOPES



4.1.13 BMP 13: Check Dam

Small dams constructed across a swale or ditch to reduce velocities of concentrated flows, thereby reducing erosion in the swale or ditch. Check dams not only prevent gully erosion from occurring before vegetation is established, but also allow a significant amount of suspended sediment to settle out.

- Check Dams can be constructed from a variety of materials
 - Rock: Rock material only
 - Bio-filter Bags: Bio-filter bags staked to the ground
 - Sand Bags
 - Prefabricated Check Dam System: A manufactured system specifically designed to slow water so that suspended particles settle out. Field fabricated systems are not allowed.

Advantages

- Prevent erosion and promote settling of sediment in runoff
- When carefully located and constructed, check dams may function as permanent installations and reduce flow velocity.
- Inexpensive and easy to install
- Rock can be spread into ditch and used as a channel lining when the check dam is no longer necessary.
- Some pre-fabricated check dams are reusable.

Disadvantages

- Removal may be costly for some types of check dams
- Suitable only for a limited drainage area
- May reduce hydraulic capacity of the channel
- May create turbulence downstream, causing erosion of the channel banks
- Pondered water may kill grass in grass-lined channels
- May be an obstruction to construction equipment

Design Criteria

- Space check dams according to the following table. Spacing shall be measured from toe of upstream check down to notch in downstream check dam.

Table 4-9 Spacing for Check Dams

Ditch Grade	Minimum Weir Depth		
	6 inch	12 inch	18 inch
6%	**	16 feet O.C.	26 feet O.C.
5%	**	20 feet	30 feet
4%	**	26 feet	40 feet
3%	15 feet	33 feet	50 feet
2%	25 feet	50 feet	80 feet

** Not Allowed

- In temporary or permanent channels not yet vegetated when installing channel lining is not feasible
- In small open channels that drain 10 acres or less
- Not for use in streams or rivers
- Construct rock check dams sized to stay in place given the expected design flow velocity. Typical rock size of three- six-inch. Place rock by hand or by mechanical means rather than dumping the rock.
- Bridge entire ditch or swale width and ensure the center of the dam is six inches lower than the outer ends
- Remove check dams from grass-lined ditches and swales when the grass is established
- Seed, mulch, or mat the area where the check dams were, immediately following removal

Inspection and Maintenance

- Inspect once per week on active sites, once every two weeks on in-active sites, and within 24 hours following a 0.5-inch rain event
- Remove sediment once it reaches one-third the depth of the rock weir
- Replace rock weir when filtering capacity is reduced by one-half

Diagram 4.1.13a
CHECK DAM - ROCK

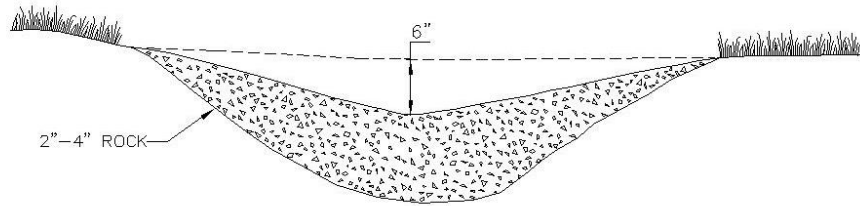

ROCK CHECK DAM

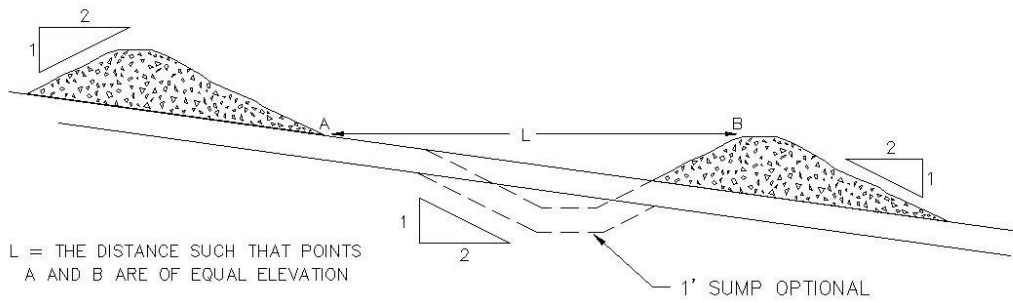

SPACING BETWEEN CHECK DAMS

Diagram 4.1.13b
CHECK DAM – BIO FILTER BAG

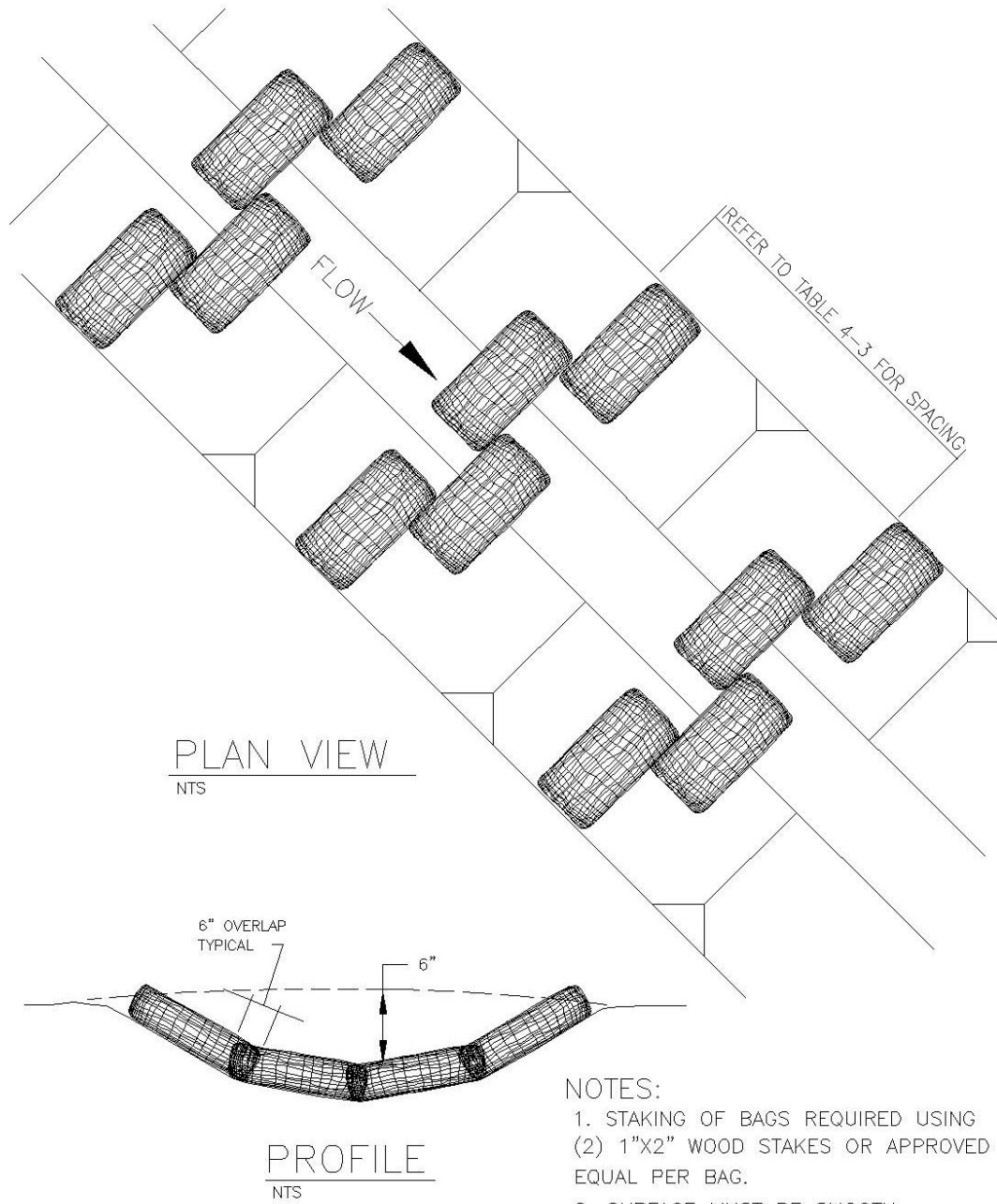

4.1.14 **BMP 14: Diversion Dike/ Swale**

A ridge of compacted soil or a lined swale with vegetative lining located at the top, base, or somewhere along a sloping disturbed area. The dike or swale intercepts and conveys smaller flows along low-gradient drainage ways to larger conveyances such as ditches or pipe slope drains or to a stabilized outlet. Dikes and swales may be used singly or in combination with each other.

Advantages

- Provides a practical, inexpensive method to divert runoff
- Can handle flows from large drainage areas
- Use on-site material and equipment to construct

Disadvantages

- If improperly constructed, can contribute to erosion caused by concentrating the flow
- High flow velocity can damage vegetation
- Not effective for preventing illegal discharge

Design Criteria

- Refer to Table 4-10, “Dike Design Criteria” and Table 4-11, “Swale Design Criteria”
- Install the dike and/or swale horizontally at intervals across a disturbed slope. Space horizontal interceptor dikes and swales according to Tables 4-10 and 4-11.
- For slopes of erodible soils, steeper than 2:1 with more than 10 feet of vertical relief, construct benches or shorten distance between dikes or swales.
- If the dike or swale intercepts runoff from disturbed areas, discharge the runoff to a stable conveyance that routes the runoff to a sediment trap or basin.
- If the dike or swale intercepts runoff that originates from undisturbed areas, discharge the runoff to a stable conveyance that will route the runoff downslope of any disturbed areas and release the water at a stabilized outlet.
- May need matting to protect seed bed and channel from erosion

Inspection & Maintenance

- Inspect once per week on active sites, once every two weeks on in-active sites, and within 24 hours following a 0.5-inch rain event
- Immediately repair damage resulting from runoff or construction activity
- If the dike or swale regularly overflows, increase the capacity and/or frequency of the dikes/swales
- Inspect and repair as necessary after every major storm
- Minimize construction traffic over temporary dikes and swales
- Clean out clogged pipes (as part of the swale system) under roads

Table 4-10 Diversion Dike Design Criteria

Top Width	24 inch minimum	
Height	20 inch minimum Measured from upslope toe and at a 90% standard proctor compaction ASTM D698.	
Side Slopes	2:1 or flatter	
Grade	Topography Dependent	
Dike grade	Between 0.5-1%	
Slope of Disturbed Area vs. Horizontal Spacing	< 5%	300 feet
	5-10%	200 feet
	10-25%	100 feet
	25-50%	50 feet
Slope Stabilization	<5% Seed and mulch within 5 days following dike construction	
	5-40% Stabilize immediately using either sod or riprap.	
Outlet	Upslope side of dike provides positive drainage to the outlet. Provide energy dissipation as necessary to prevent erosion. Release sediment-laden runoff to a sediment trapping facility.	

Table 4-11 Diversion Swale Design Criteria

Bottom Width	24 inch. Level bottom across the swale.	
Depth	12 inch	
Side Slopes	2:1 or flatter	
Grade	Maximum 5% with positive drainage to a suitable outlet.	
Slope of Disturbed Areas. Horizontal Spacing	<5%	300 feet.
	5-10%	200 feet.
	10-25%	100 feet.
	25-50%	50 feet.
Slope Stabilization	Temporarily seed or line with riprap 12 inch thick and press into the bank approximately 3-4 inch	
Outlet	Level spreader or riprap to stabilized outlet/sedimentation pond.	

Diagram 4.1.14
DIVERSION DIKE / SWALE

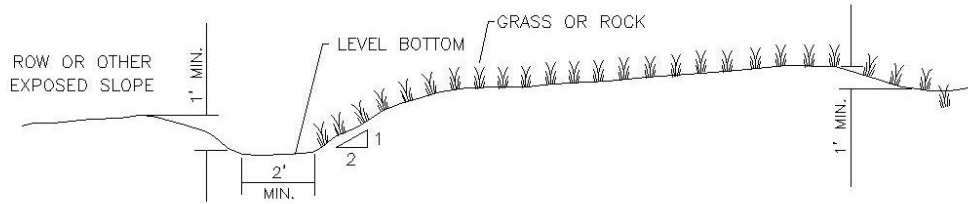

BOTTOM WIDTH	2 FEET MINIMUM; THE BOTTOM WIDTH SHALL BE LEVEL
DEPTH	1 FOOT MINIMUM
SIDE SLOPE	2H:1V OR FLATTER
GRADE	MAXIMUM 5 PERCENT, WITH POSITIVE DRAINAGE TO A SUITABLE OUTLET (SUCH AS SEDIMENTATION POND)

DIVERSION SWALE

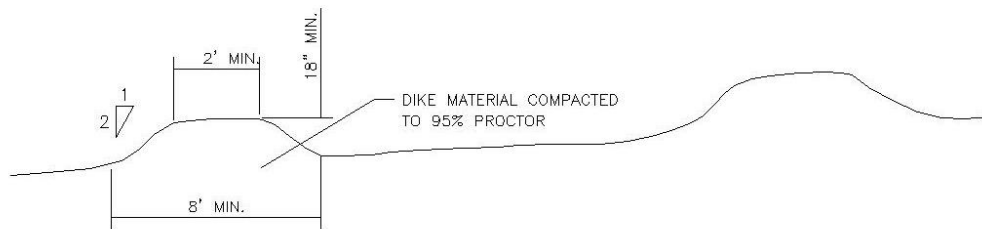

TEMPORARY DIVERSION DIKE

Slope	Spacing
<5%	300 feet
5-10%	200 feet
10-40%	100 feet

NOTE:
 IMMEDIATELY UPON CONSTRUCTION,
 ESTABLISHED VEGETATION OR EROSION
 CONTROL BLANKETS ARE REQUIRED.

4.1.15 **BMP 15: Grass-lined Swale**

A channel with vegetative lining constructed to convey and dispose of concentrated surface runoff without damage from erosion, deposition, or flooding.

Advantages

- Does not generate high velocity runoff and offers temporary slope protection, which is superior to plastic sheeting
- Capture a great deal of sediment due to the filtering effect of vegetation
- Usually easy to install

Disadvantages

- Requires temporary irrigation to establish vegetation
- Cannot be used until vegetation is established

Design Criteria

- As a minimum, grass-lined channels must carry peak runoff from a 10-year storm event without eroding. Where flood hazards exist, increase the capacity according to the potential damage. The allowable design velocity for grassed-lined channels is based on soil conditions, type of vegetation, and the method of establishment. The channel shape may be parabolic, trapezoidal, or V-shaped, depending on the need and site conditions. Small check dams or flow spreaders may be necessary to minimize channelization.

Inspection and Maintenance

- Inspect once per week on active sites, once every two weeks on in-active sites, and within 24 hours following a 0.5-inch rain event
- During the initial establishment, grass-lined channels should be repaired and grass re-established when necessary
- After grass has become established, the channel should be checked periodically to determine if the channel is withstanding flow velocities without damage
- Check the channel for debris, scour, or erosion and immediately make repairs. It is particularly important to check the channel outlet and all road crossings for bank stability and evidence of piping or scour holes and make repairs immediately
- Remove all significant sediment accumulations to maintain the designed carrying capacity
- Keep the grass in a healthy, vigorous condition at all times, since it is the primary erosion protection for the channel
- Permanent grassed waterways should be seasonally maintained by mowing and/or irrigating, depending on the type of vegetation selected
- Newly seeded areas need to be inspected frequently to ensure the grass is growing
- If the seeded area is damaged due to runoff, additional stormwater measures such as check dams or matting may be needed

4.2 Sediment Control Practices

4.2.1 **BMP 16: Sediment Fence**

Temporary sediment trap consisting of an entrenched geotextile stretched across and attached to supporting posts. Sediment fences are adequate to treat flow depths consistent with overland or sheet flow. Standard or heavy-duty sediment fence fabric must meet specific ASTM requirements, outlined in Table 4-13.

Advantages

- Reduces runoff velocity
- Requires minimal ground disturbance to install
- Relatively inexpensive

Disadvantages

- Applicable to small drainage areas and overland flow; not applicable to concentrated flows
- Incorrect geotextile or installation decreases sediment fence performance
- Requires frequent maintenance and inspection

Design Criteria

- See Table 4-13 for Sediment Fence Fabric Specifications
- Show sediment fence installed along ground contours according to Table 4-12
- Sediment fence should only be used for sheet and rill erosion
- Standard or heavy-duty sediment fence filter fabric shall have manufactured stitched loops with 2" × 2" × 4' posts. Stitched loops shall be installed on the uphill side of the sloped area.
- Sediment fences should be installed a minimum of 3 feet from toe of slope in order to maximize storage.
- When sediment fence approaches its termination point, turn fence uphill and extend one full panel (6 ft).
- When joining two or more sediment fences together, join the two end stakes by wrapping the two ends at least one and one half turns and driving the joined stakes into the ground together.
- Height of a sediment fence should not exceed 3 feet. Storage height and ponding height shall not exceed 50% of the height of the fence.

Table 4-12 Barrier Spacing for General Application

BARRIER SPACING FOR GENERAL APPLICATION

INSTALL PARALLEL ALONG CONTOURS AS FOLLOWS		
% Slope	Slope	Maximum Spacing on Slope
10 % Flatter	10:1 or Flatter	300 ft
10 > % < 15	10:1 > x < 7.5:1	150 ft
15 > % < 20	7.5:1 > x < 5:1	100 ft
20 > % < 30	5:1 > x < 3.5:1	50 ft
30 > % < 50	3.5:1 > x < 2:1	25 ft

Table 4-13 Sediment Fence Fabric Specifications

WOVEN POLYPROYLENE SEDIMENT FENCE FABRIC

PROPERTY	TEST PROCEDURE	MINIMUM FABRIC VALUE
Grab Tensile Strength	ASTM D-4632	180 lbs.
Grab Elongation	ASTM D-4632	15%
Trapezoid Tear	ASTM D-4533	70 lbs.
Mullen Burst	ASTM D-3786	300 psi
Puncture	ASTM D-4833	80 lbs.
Permittivity	ASTM D-4491	.07 sec - 1
Permeability	ASTM D-4491	.005 cm/sec
Apparent Opening Size (AOS)	ASTM D-4751	50 U.S. Sieve
UV Resistance (500 hrs.)	ASTM D-4355	90%

Inspection & Maintenance

- Inspect once per week on active sites, once every two weeks on in-active sites, and within 24 hours following a 0.5-inch rain event
- Immediately repair any damage
- Remove accumulated sediment once it has reached 1/3 the height of the sediment fence or 1 ft maximum
- Inspect for channel formation parallel to the fence, which indicates the geotextile is acting as a flow barrier
- Replace deteriorated or clogged geotextile
- Check for under cutting or piping under fence

Diagram 4.2.1
SEDIMENT FENCE

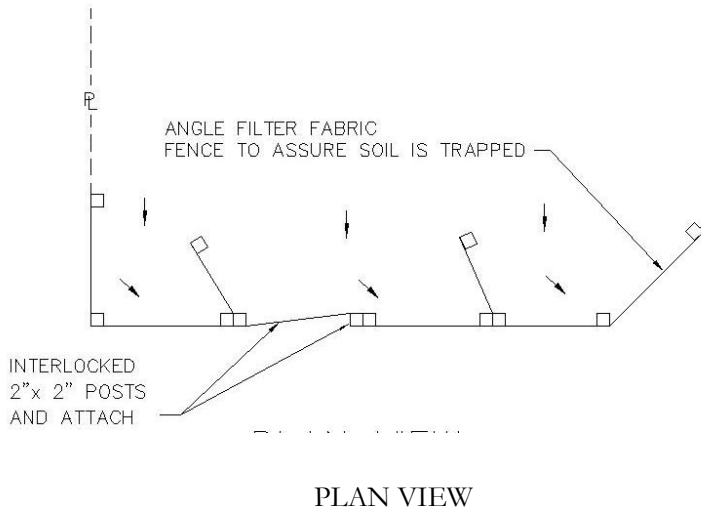
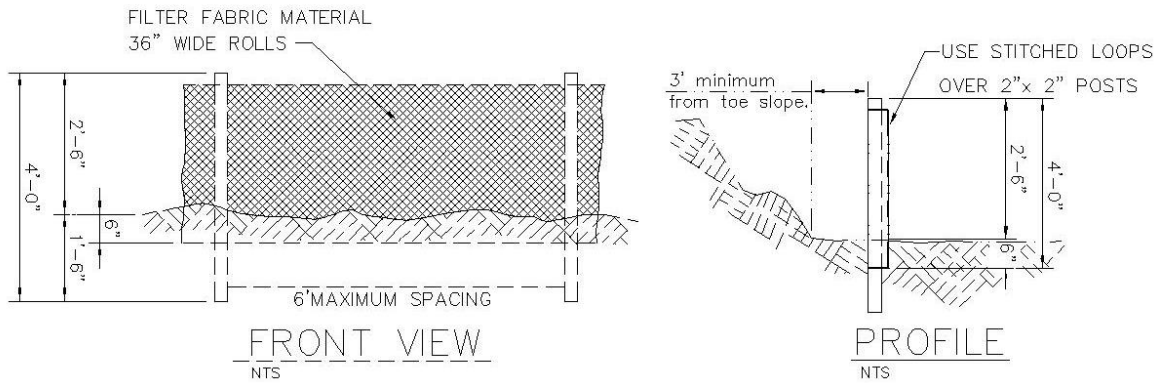

NOTES:

1. BURY BOTTOM OF FILTER FABRIC 6" VERTICALLY BELOW FINISHED GRADE.
2. 2"x 2" FIR, PINE OR STEEL FENCE POSTS.
3. POSTS TO BE INSTALLED ON UPHILL SIDE OF SLOPE.
4. COMPACT BOTH SIDES OF FILTER FABRIC TRENCH.

4.2.2 **BMP 17: Biofilter Bags**

Biofilter bags are manufactured from 100 percent recycled wood-product waste placed in plastic mesh bags.

Advantages

- Relatively low cost
- Can be used in place of sediment fences at toe of slope, without trenching in
- Wood-product can be recycled or used on site when no longer needed
- Installation is simple, can be done by hand
- Bags are easy to move, replace, and reuse on paved surfaces
- Are good short-term solutions in situations where concentrated flows are causing erosion

Disadvantages

- Generally effective for only a few months
- Can be easily damaged by construction equipment or by traffic in paved areas
- Can become clogged with sediment and cease to filter runoff
- If improperly installed can allow undercutting or end-flow
- Not effective where water velocities or volumes are high
- Light weight results in higher buoyancy if not properly installed
- Low sediment retention capacity may require frequent maintenance

Design Criteria

- Bio-filter bags are to be clean, 100 percent recycled wood product waste, standard size 10 × 8 × 30 inches, weight approximately 45 pounds, with ½-inch plastic netting
- May be left in place or used as mulch once they have served their purpose
- Surface area should be smooth
- Use (2) 1 × 2 inch stakes per bag, driven 12 inches into ground.
- Ends of bags must be overlapped six inches to prevent piping between joints.

Inspection and Maintenance

- Requires routine inspection
- Check that stakes are secure and ends of bags are tightly overlapped. Check that undercutting or end-flow is not occurring.
- Inspect plastic mesh bags for tears
- Remove sediment when 1/3 height of bag has accumulated
- Replace damaged bags as needed

Diagram 4.2.2
BIOFILTER BAGS

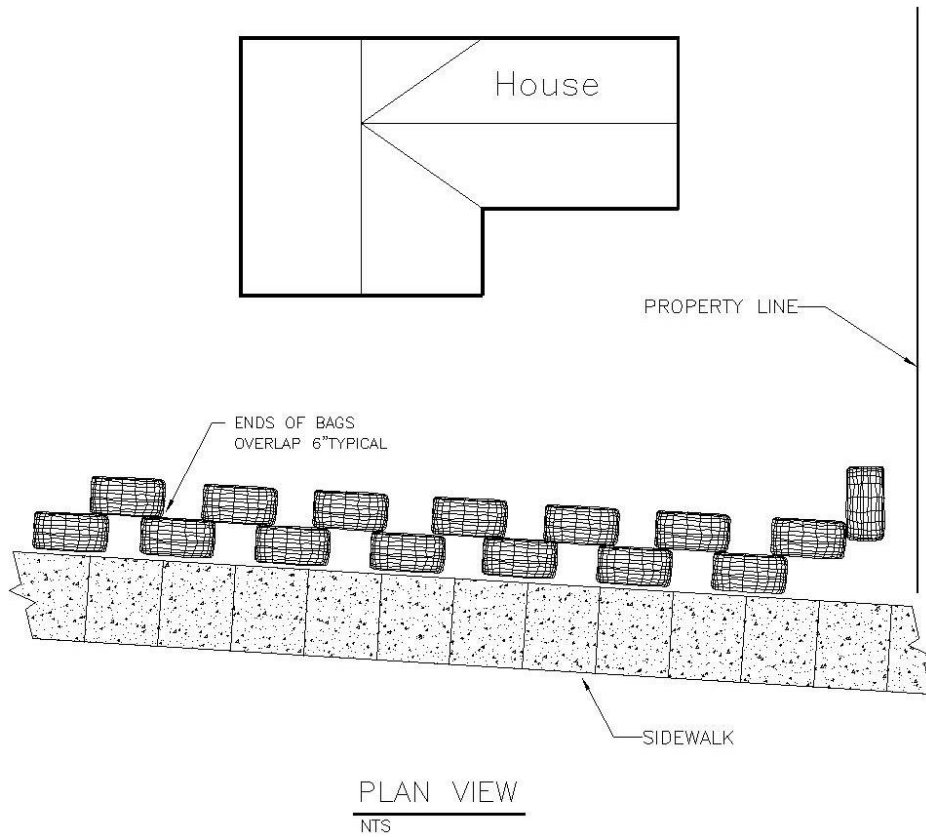

NOTE:

1. STAKING OF BAGS REQUIRED USING (2) 1" x 2" WOOD STAKES OR APPROVED EQUAL PER BAG.
2. BAGS ARE USED AS ALTERNATE FOR SEDIMENT FENCE FOLLOWING INSTALLATION OF SIDEWALK ON SINGLE FAMILY CONSTRUCTION ONLY.

4.2.3 **BMP 18: Sand Bags**

Sandbags are manufactured from durable, weather-resistant, tightly woven, Geotextile fabric material sufficient to prohibit leakage of the filler material. Minimum size of bags measure 24 × 12 × 6 inches and be filled with firmly packed sand weighing at least 75 pounds.

Advantages

- Relatively low cost
- Installation is simple, can be done by hand
- Bags are easy to move, replace, and reuse on paved surfaces
- Are good short-term solution in situations where concentrated flows are causing erosion
- Can be used to divert and slow velocity of small flows
- Can be used in concrete lined ditches to capture sediment and reduce water velocity

Disadvantages

- Generally effective for only a few months
- Can be easily damaged by construction equipment or by traffic in paved areas
- Can contribute sediment to runoff if bags rupture
- Cannot be staked and are not appropriate on steep slope applications
- Not effective in steep swales, channels, or ditches
- If improperly installed can allow undercutting or end-flow
- Not effective where water velocities or volumes are high, can get washed away

Design Criteria

- Generally used in ditches and/or swales as a check dam
- Can be used on highway or road projects to divert run-off
- Ends of bags must be tightly abutted and overlapped to direct flow away from bag joints

Inspection and Maintenance

- Inspect once per week on active sites, once every two weeks on in-active sites, and within 24 hours following a 0.5-inch rain event
- Check that ends of bags are tightly abutted. Check that undercutting or end-flow is not occurring.
- Remove sediment accumulated behind bags when sediment reaches one-third of the barrier height.
- Replace damaged bags as needed

4.2.4 **BMP 19: Filter Berm**

Sediment is retained in gravel or crushed rock berm.

Advantages

- Very efficient method for sediment removal
- Reduces runoff velocity

Disadvantages

- More expensive than some other measures because requires clean gravel or crushed rock rather than materials found onsite
- Clogging from mud and soil may make maintenance difficult
- Has a limited life span

Design Criteria

- Use two inches maximum washed and well-graded gravel or crushed rock with less than five percent fines
- Berm Dimensions:
 - Height and side slopes: one foot high with 3:1 side slopes
 - Length: Eight feet per one cubic foot per second flow, based on the peak flow for the 10-year storm
 - If used as slope application, use Table 4-12 for spacing
 - Used primarily as a base measure (toe of slope)

Inspection and Maintenance

- Inspect once per week on active sites, once every two weeks on in-active sites, and within 24 hours following a 0.5-inch rain event
- Remove and replace rock when filtering capacity is reduced by half to maintain performance.
- Removed sediment accumulation when it reaches one-third of the barrier height.

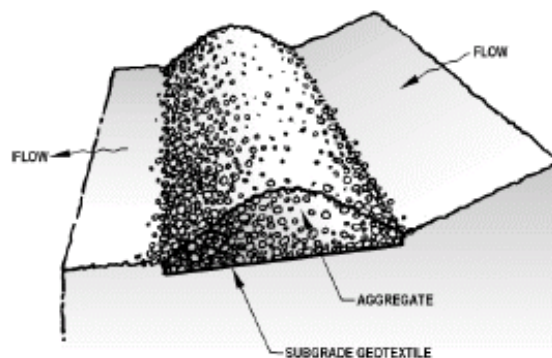
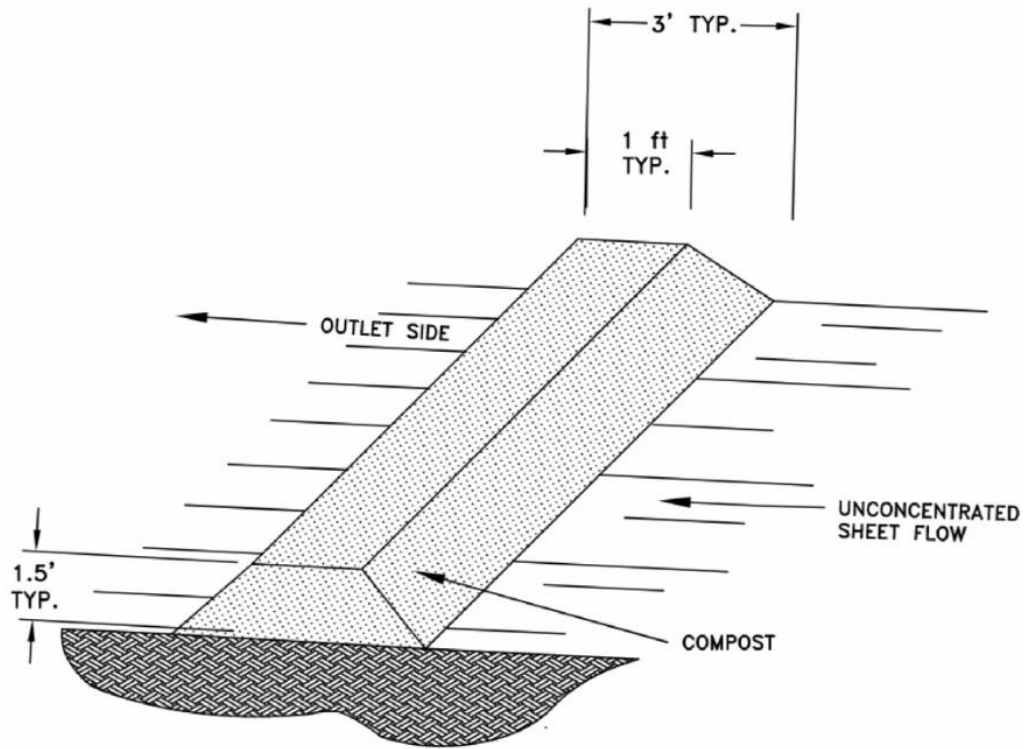

Diagram 4.2.4
FILTER BERM



COMPOST FILTER BERM

NOTES:

1. COMPOST FILTER BERM WILL BE INSTALLED USING YARD DEBRIS WELL COMPOSTED ORGANIC MATTER, FREE OF METALS, PLASTICS, AND OTHER FOREIGN MATTER.
2. COMPOST SIZING WILL BE COARSE GRADE 1 1/2".

4.2.5 **BMP 20: Wattles**

Wattles are manufactured from straw, coconut, or other material wrapped in tubular plastic netting. They are approximately eight to nine inches diameter by seven to 25 feet long. Wattles are placed in shallow trenches and staked along the contour of newly constructed or disturbed slopes.

Advantages

- They can often replace sediment fences on steep slopes
- Wattles store moisture for vegetation planted immediately upslope
- May be left in place to biodegrade and/or photodegrade, adding organic material to the soil
- Reduces runoff velocity
- Light weight and easy to install

Disadvantages

- Wattles only function for one or two seasons.
- If not installed properly with sufficient trench, wattles may fail during the first rain event
- Wattles may require maintenance to ensure the stakes are holding and the wattles are still in contact with the soil. This is especially true on steep slopes in sandy soil
- Low sediment retaining capacity may require frequent maintenance

Design Criteria

- Wattles can be made from straw, coconut, or other approved material
- Slope requires minor preparation prior to installation
- Rills and shallow gullies should be smoothed as work progresses
- Wattles shall be installed on contours. Trench should be deep enough to accommodate half the thickness of the wattle
- Wattles should be installed from the bottom of the slope up
- Wattle must be tight against the soil with no gaps between the soil and the wattle in the trench
- If live willow stakes are installed, use a straight bar to drive holes through wattles
- Stakes must be driven a minimum of 12 inches into undisturbed material
- Install stakes every four feet. Additional stakes may be needed on highly erosive or very steep slopes

Inspection and Maintenance

- Inspect once per week on active sites, once every two weeks on in-active sites, and within 24 hours following a 0.5-inch rain event
- Make sure the wattles are in contact with the soil

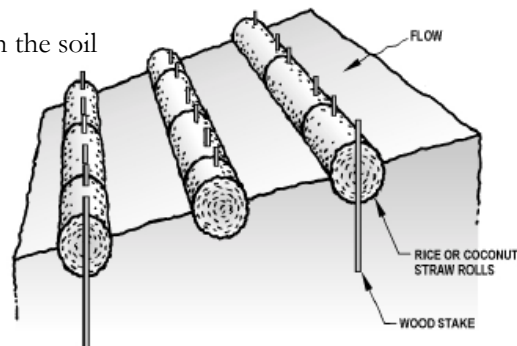
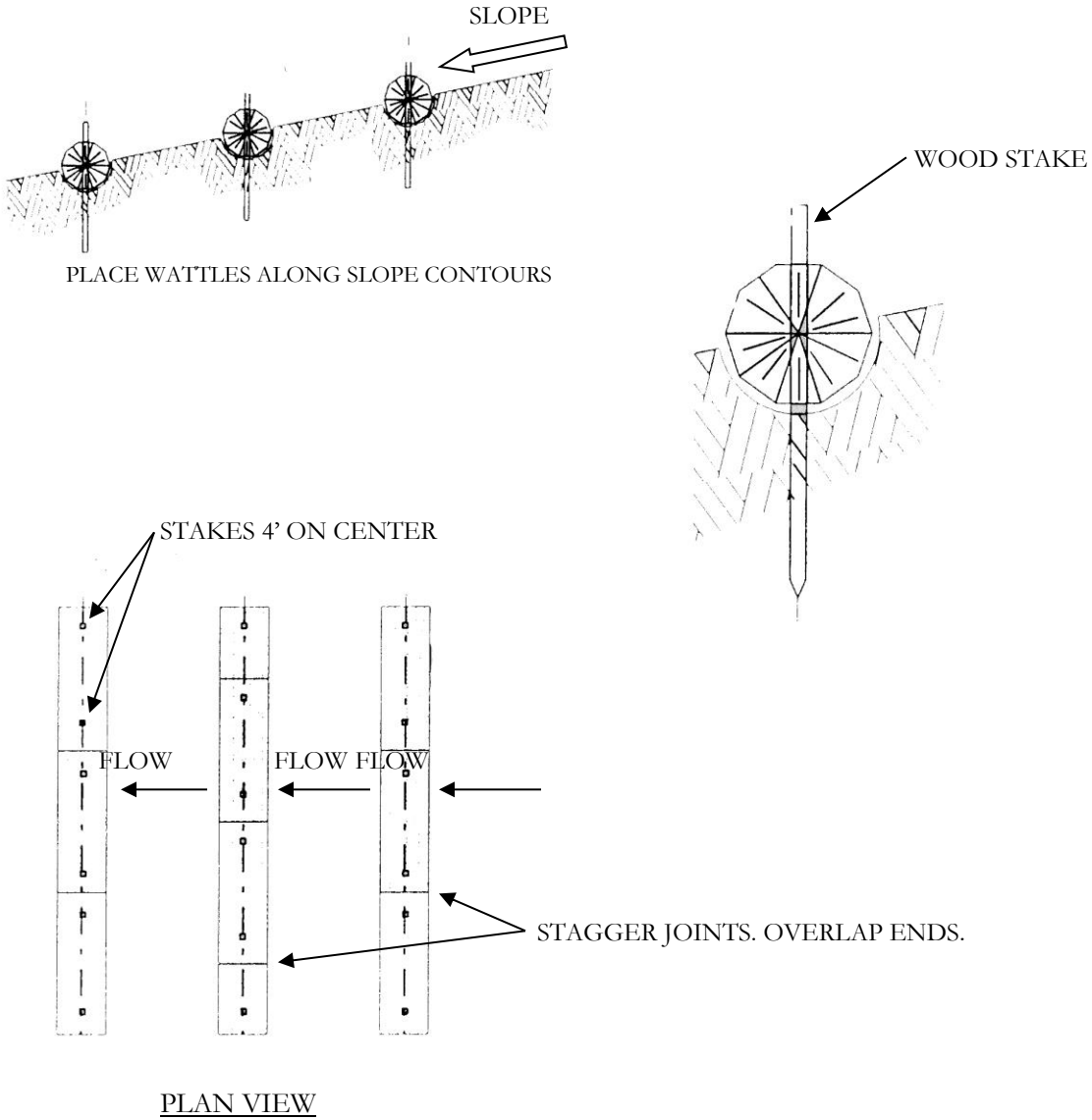

Diagram 4.2.5
WATTLES



4.2.6 **BMP 21: Compost Filter Sock:**

Compost Filter Socks are manufactured from Yard Debris Coarse Grade well composted organic matter wrapped in either tubular plastic, cotton, or burlap material. They are approximately eight to nine inches in diameter by seven to 25 feet long. Compost Filter Socks can be laid flat on most surfaces and require staking along the contour of newly constructed or disturbed slopes.

Advantages

- Use as a filtering perimeter sediment control
- Recommended replacement for control measures not requiring soil disturbance or trenching; Compost Filter Socks can be laid directly on asphalt, concrete, or any other permanent surface
- Recommended filtering replacement for perimeter controls along natural areas and buffers
- Can be used to store moisture for vegetation planted immediately upslope
- May be left in place to biodegrade and/or photodegrade, adding organic material to the soil
- Energy dissipation of sheet and concentrated flows
- Can be used for slope interruption to reduce sheet flow velocity.
- Can be used on paved, compacted, frozen, or tree-rooted areas where trenching is not possible or is undesirable
- Used in biofiltration and bioremediation of stormwater pollutants
- Can be used in low impact development (LID), green infrastructure, and green building programs

Disadvantages:

- Compost Filter Socks only function for one or two seasons
- Compost Filter Socks may fail if not staked in on slopes or do not make direct contact with the ground
- Compost Filter Socks may require maintenance to ensure the stakes are holding on slopes and are still in contact with the soil. This is especially true on steep slopes in sandy soil
- Lower sediment retaining capacity may require frequent maintenance

Inspection and Maintenance:

- Inspect once per week on active sites, once every two weeks on in-active sites, and within 24 hours following 0.25-inch rain event
- Make sure Compost Filter Socks are in contact with the surface it is installed on

Diagram 4.2.6 COMPOST FILTER SOCK

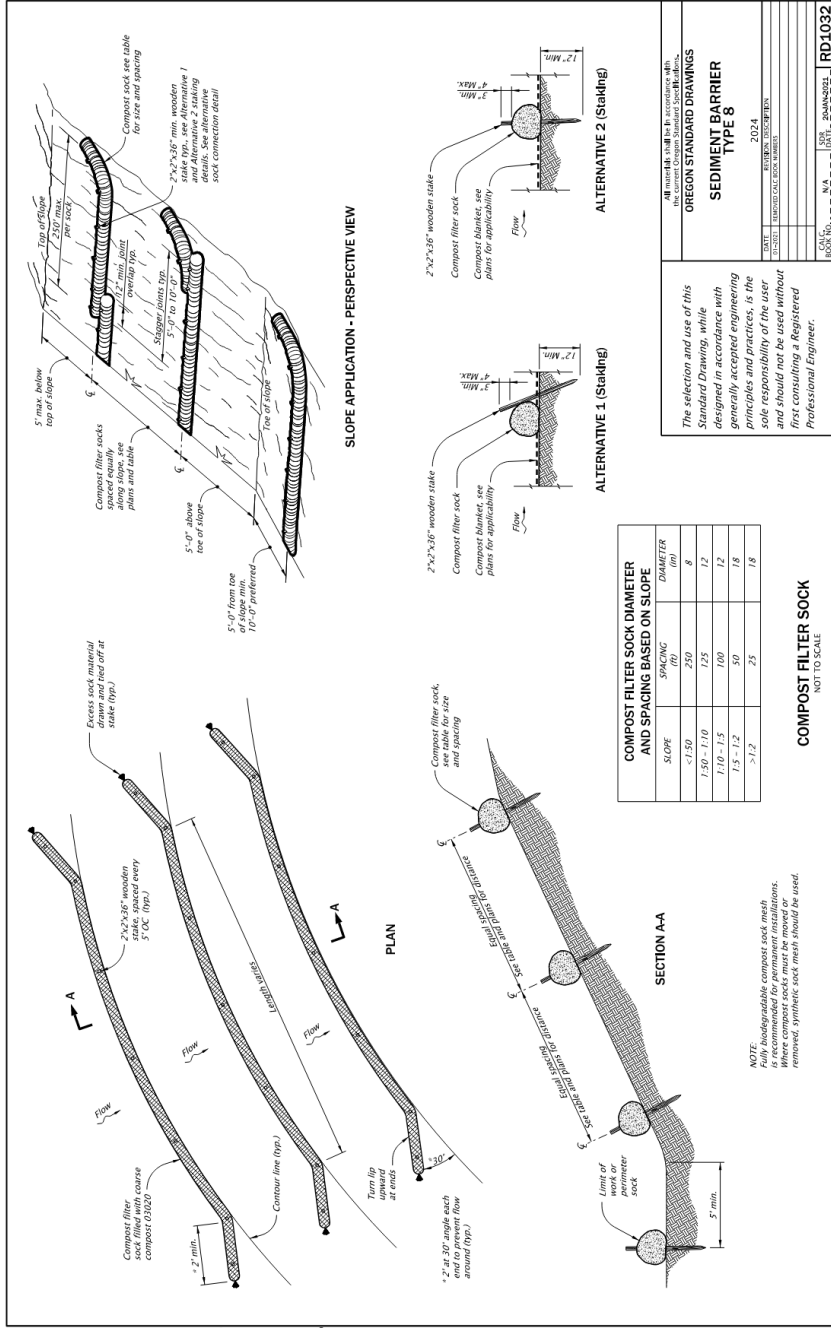

Source: ODOT Standard Construction Drawings

4.2.7 **BMP 22: Sidewalk Sub-grade Gravel Barrier**

A sidewalk sub-grade gravel barrier is an application that provides storage and filtration from run-off on sites with mild slopes. It can be used on all types of projects but generally on single family dwellings. Normal installation occurs when excavating for footing and foundation.

Advantages

- Easy to install
- Very economical
- Can retain suspended soils

Disadvantages

- May require additional measure depending upon soil type
- May need periodic maintenance for removal of suspended materials
- May not be an adequate sediment barrier for steep lots or concentrated flows

Design Criteria

- Install where the site slopes to a street with curbs and slopes are five percent or less
- Plug all weep holes in curb
- Sidewalk sub-grade must have a minimum four-inch depth and a four-foot width.
- A two-inch layer of approved sub-base material must be installed
- A gravel filter berm may be installed along the inside edge, or toe of slope to increase filtration
- Install sediment barrier on the downhill corner of property to intercept run-off
- On development sites, install sidewalk sub-grade as part of post construction
- On single family sites, install as part of the footing/foundation excavation
- If sidewalk concrete is to be poured prior to establishment of permanent site cover, approved sediment barriers must be installed prior to pouring sidewalk
- Sidewalk construction is required to conform to the City of Albany *Standard Construction Specifications*, in addition to measures undertaken in this section

Inspection and Maintenance

- Inspect once per week on active sites, once every two weeks on in-active sites, and within 24 hours following a 0.5-inch rain event
- Remove and replace gravel when filtering capacity is reduced by half, to maintain performance

Diagram 4.2.7
SIDEWALK SUBGRADE GRAVEL BARRIER

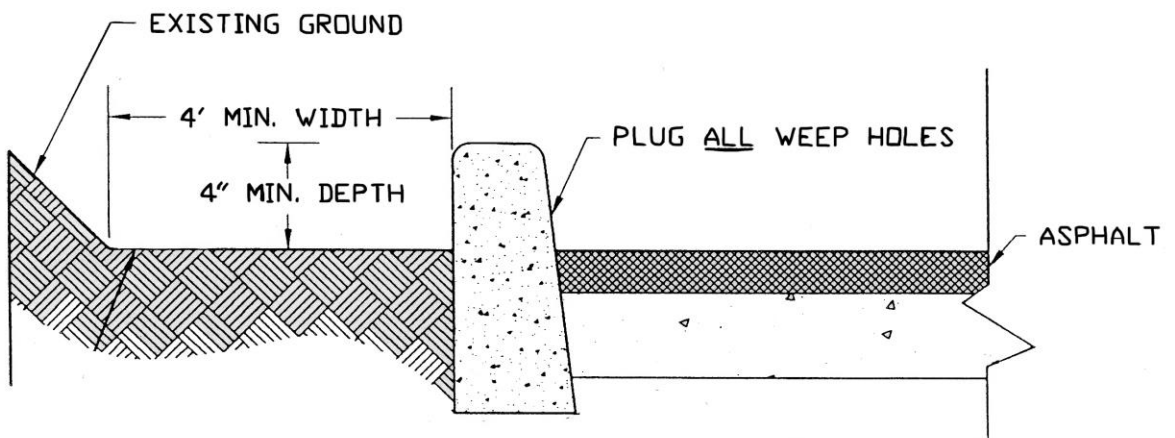
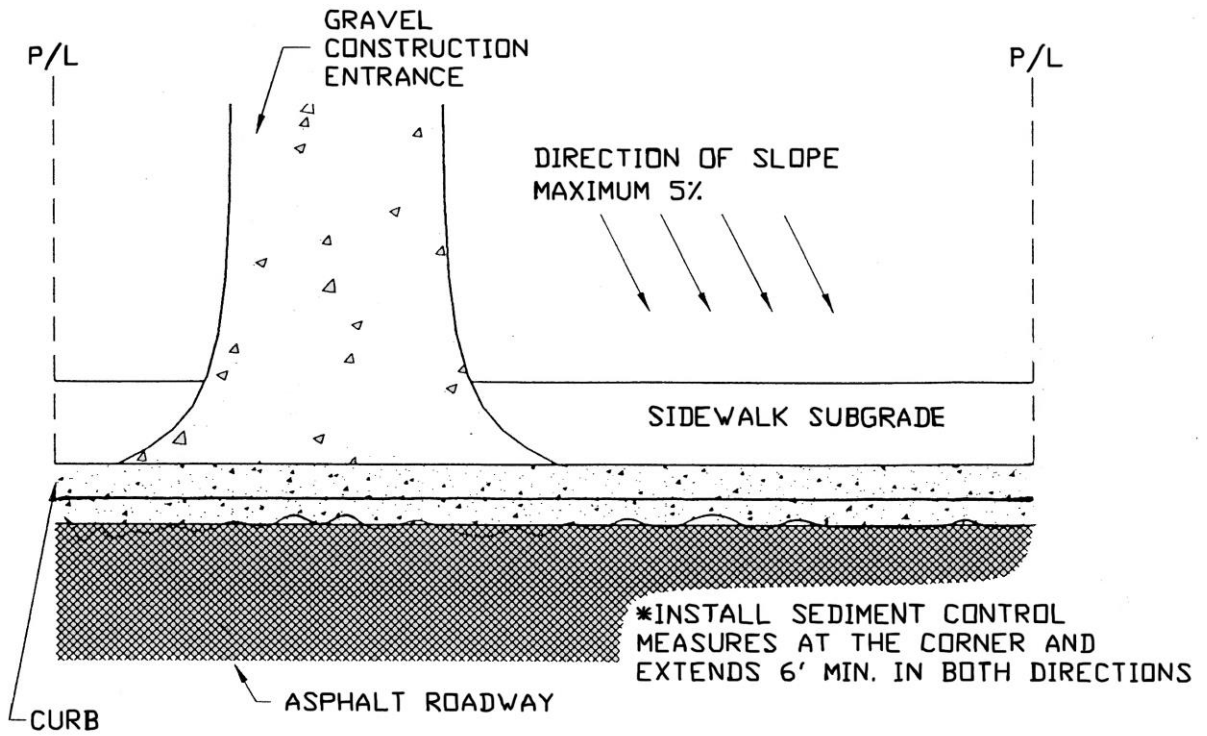

4.2.8 **BMP 23: Inlet Protection**

This BMP prevents coarse sediment from entering the storm drainage system by filtering runoff and retaining sediment before it reaches a drainage inlet or the storm sewer system. There are many options and variations of inlet protection available.

Advantages

- Prevents sediment from entering the storm drain system
- Reduces amount of sediment leaving the site

Disadvantages

- May result in ponding of water above the catch basin
- Sediment removal may be difficult under high flow conditions
- May result in a traffic hazard
- Short-circuiting of flow may occur if not properly installed
- Useful only for low flows having low sediment loading
- Improper installation, maintenance, or removal may introduce sediment into the storm drain system

Design Criteria

- Place inlet protection in areas where water can pond, and where ponding will not have adverse impacts
- Inlet protection must allow for overflow in a severe storm event
- Addition measures must be considered depending upon soil type
- Inlet protection types include
- Type 1 – Rock and wire mesh
- Type 2 – Masonry and rock
- Type 3 – Sediment fence
- Type 4 – Biofilter bags
- Type 5 – Catch basin insert

Inspection and Maintenance

- Inspect once per week on active sites, once every two weeks on in-active sites, and within 24 hours following a 0.5-inch rain event
- Clean inlet protection during and after each significant storm and remove sediment from behind structure after every storm
- If the rock becomes clogged with sediment, it must be carefully removed from the inlet and either cleaned or replaced
- Assess the impacts of allowing water to pond at the inlet and provide an overflow weir or some other type of relief as needed
- Consider the effect of placing obstructions at inlets on grade may have on their efficiency
- Use mechanical means to remove sediment deposits (shovel, broom, sweeper/vactor unit)
- Remove sediment accumulated on or around the protection as needed to maintain intended functions
- Repair or replace materials as needed to ensure proper functioning

Masonry / Aggregate
Type 2

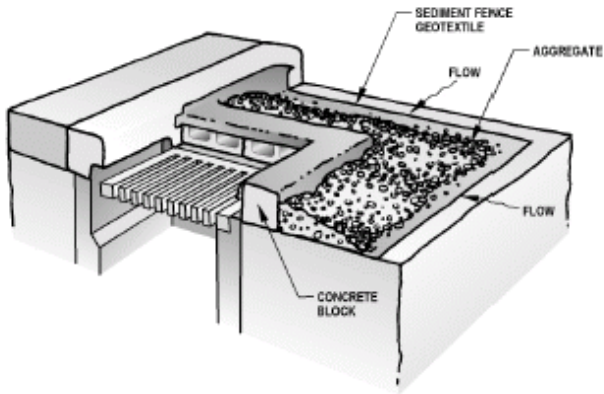

Prefabricated Filter Insert
Type 5

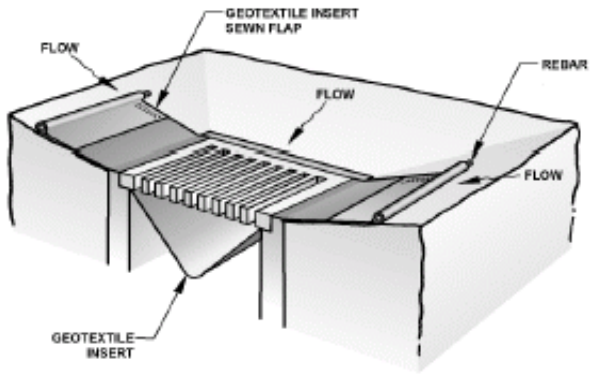

Biofilter Bags Around Catch Basin
Type 4

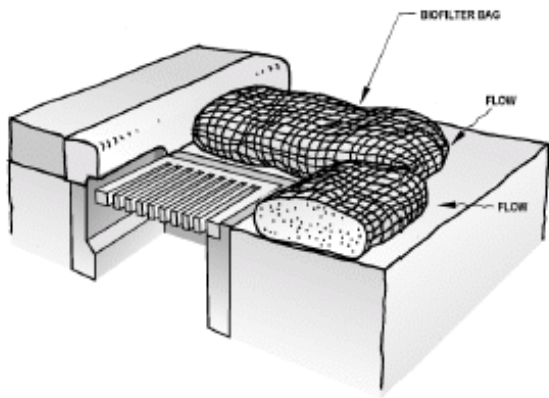

Biofilter Bags Around Area Drain
Type 4

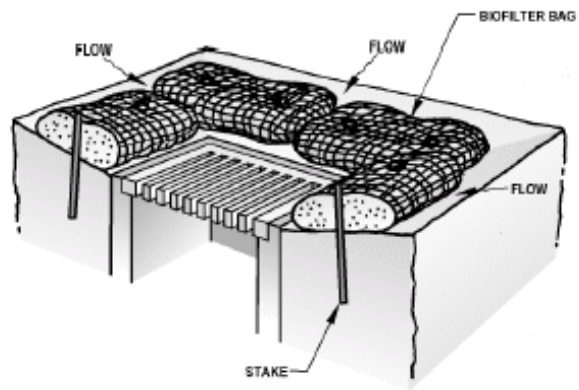
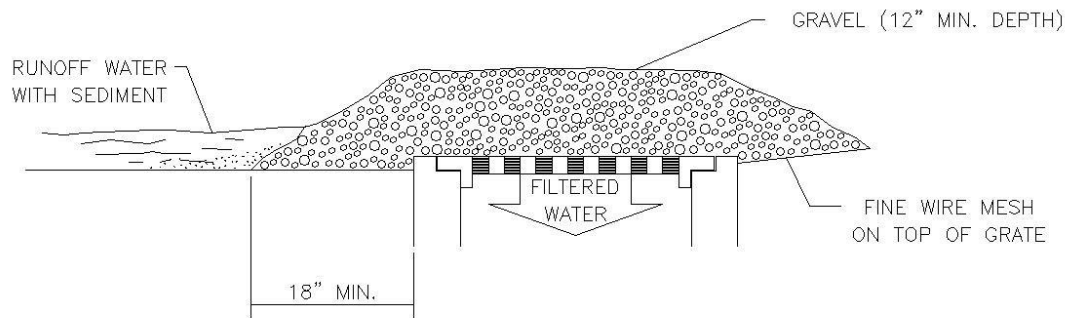

Diagram 4.2.8a

INLET PROTECTION TYPE 1



GRAVEL & WIRE MESH

Diagram 4.2.8b
INLET PROTECTION TYPE 2

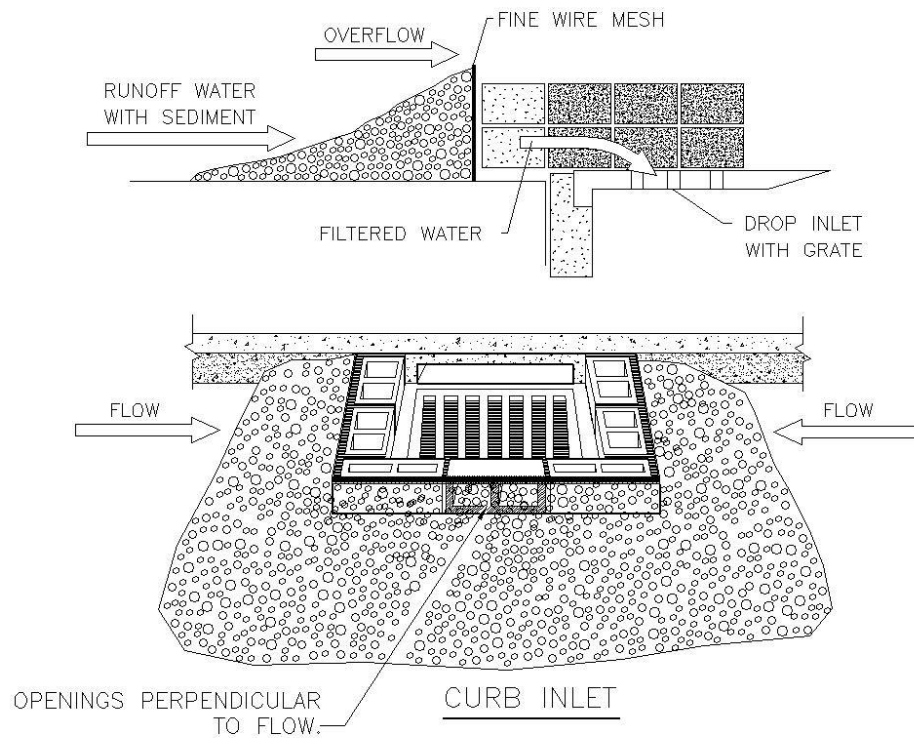
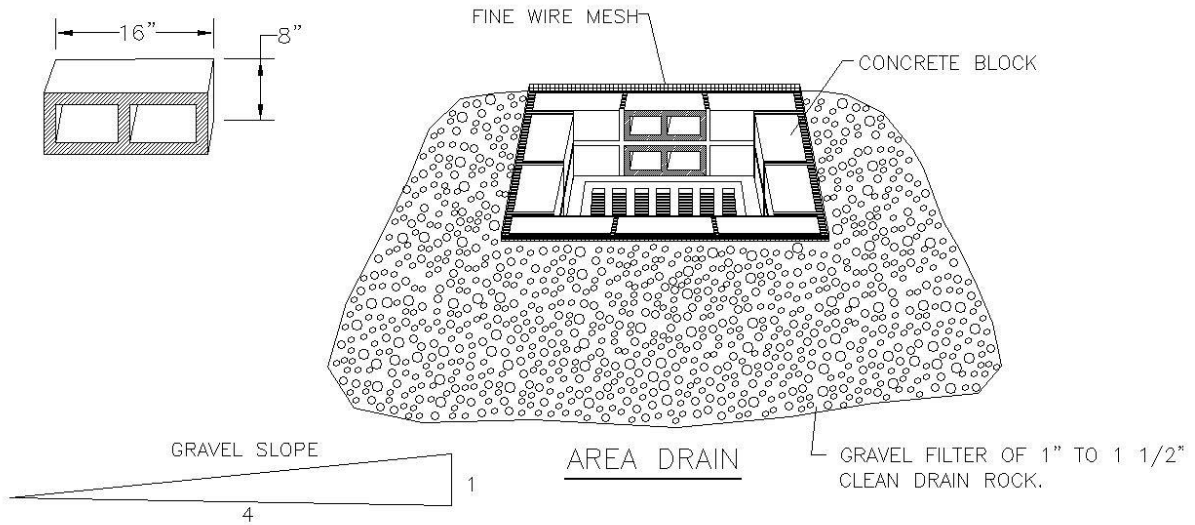

BLOCK AND GRAVEL INLET BARRIERS

NOTE:

1. BLOCKS SHALL BE STACKED WITH THE OPENINGS ON THE TOP AND BOTTOM EXCEPT FOR THE CENTER BLOCKS. CENTER BLOCKS WILL HAVE OPENINGS PERPENDICULAR TO FLOW.

Diagram 4.2.8c
INLET PROTECTION TYPE 3

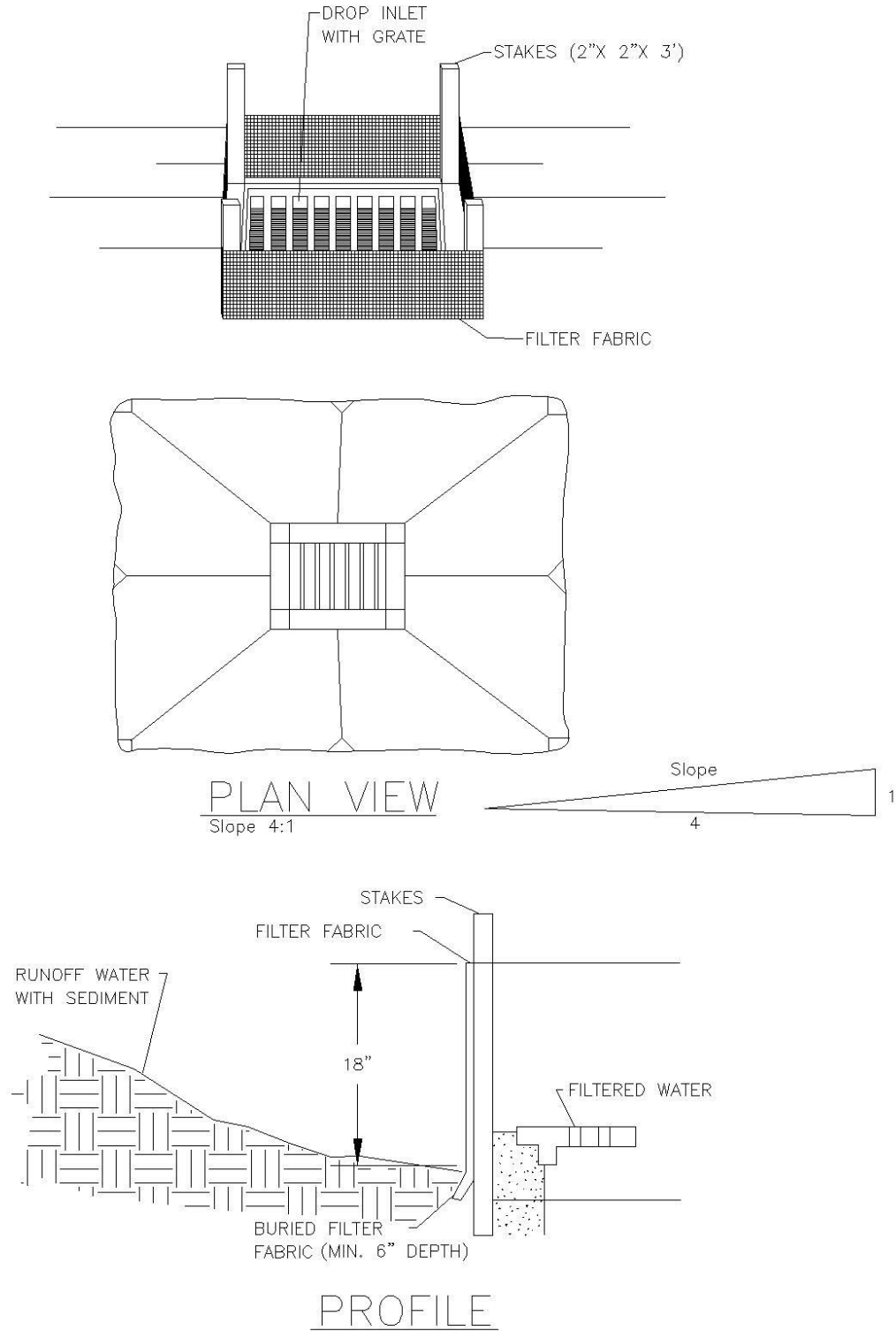
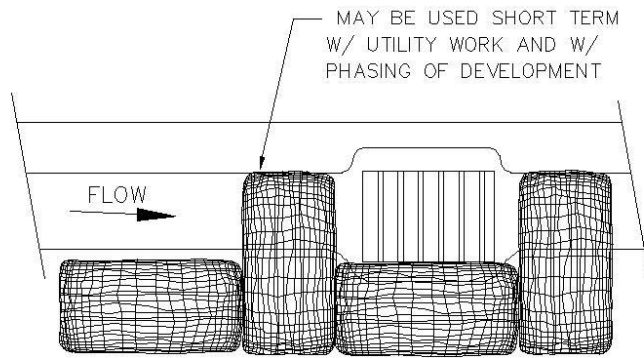
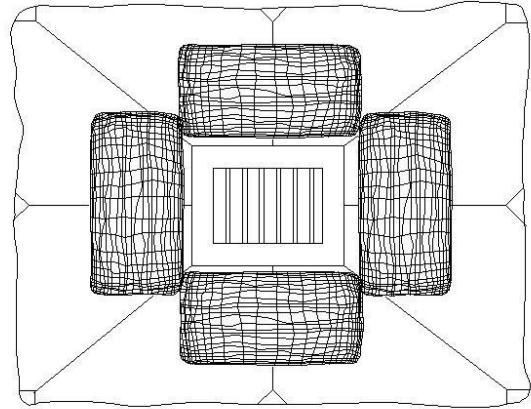

Diagram 4.2.8d
INLET PROTECTION TYPE 4



CATCH BASIN



AREA DRAIN

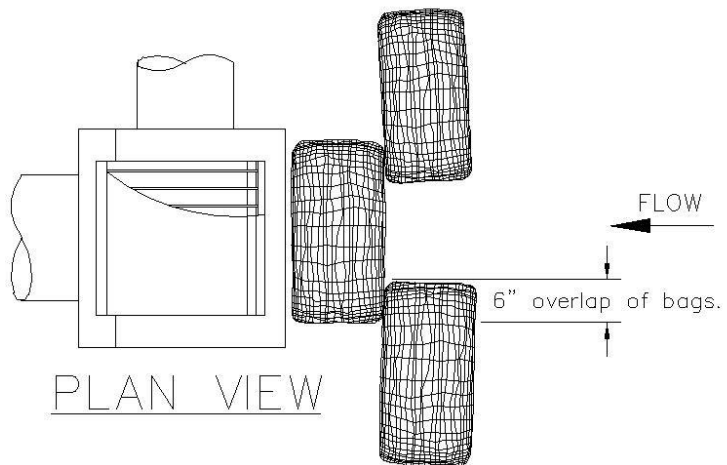

PLAN VIEW

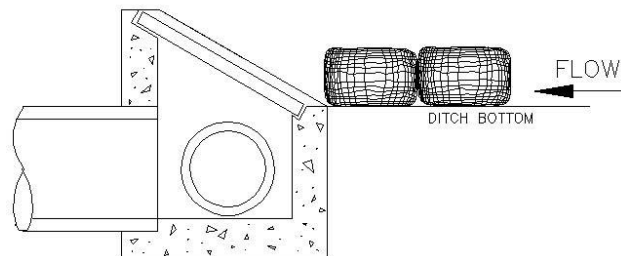

DITCH INLET

NOTES:

1. ADDITIONAL MEASURES MUST BE CONSIDERED DEPENDING ON SOIL TYPES.
2. BIOFILTER BAGS SHOULD BE STAKED WHERE APPLICABLE USING (2) 1"x2" WOODEN STAKES OR APPROVED EQUAL PER BAG.

Diagram 4.2.8e
INLET PROTECTION TYPE 5

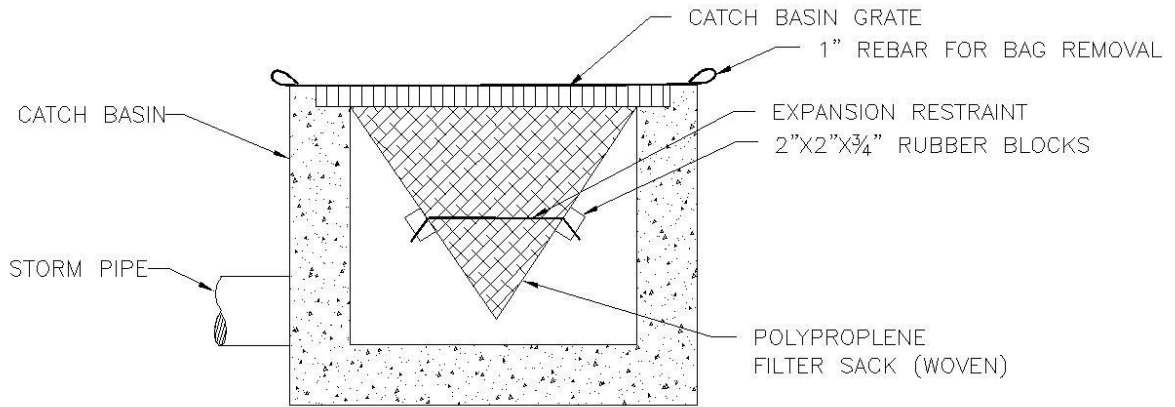

WOVEN POLYPROPYLENE SACK

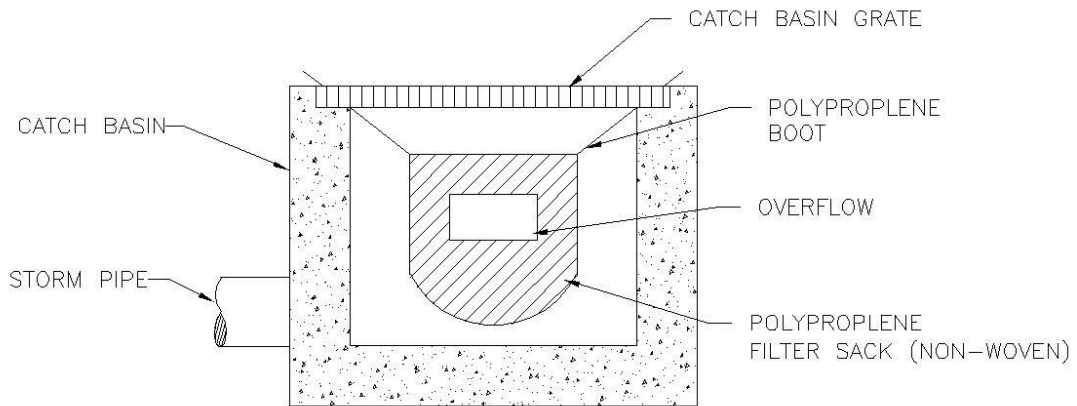

NON-WOVEN POLYPROPYLENE SACK

NOTE:
 1. RECESSED CURB INLET CATCH BASINS MUST BE BLOCKED WHEN USING FILTER FABRIC INLET SACKS. SIZE OF FILTER FABRIC INLET SACKS TO BE DETERMINED BY MANUFACTURER.

4.2.9 **BMP 24: Dewatering**

Temporary settling and/or filtering devices for water which is discharged from dewatering operations. Filtration is the separation of sediment from a fluid by passing the fluid through a permeable medium that will trap a high percentage of the particles. This is not a new concept; it has been employed in all types of industries, for various types of liquids, including water. The equipment necessary for filtration applications associated with water containing sediment would be weir tanks, gravity boxes, non-contained sediment bags, sand media filtration, and bag/cartridge chambers. There are two types of filtration systems, gravity, and pressure.

Advantages

- Excellent for utility work such as repairs, replacements, or new installations
- Depending upon the choice of filtration systems, can remove small particles of silt and clays
- Can be used as an alternate to sediment trap/basin on smaller sites
- Can hold large amounts of sediment which reduces overall maintenance
- Can be used in conjunction with other types of filters as a pre-filter
- Can be easily mobilized from site to site

Disadvantage

- Limited storage capacity depending upon the site
- Have limitations in removing silts and clays, depending upon selection
- May require heavy equipment to load and unload system
- May be cost inhibitive

Design Criteria

- Determine soil type prior to selecting the type of dewatering system
- Select an appropriate location that will reduce overall impacts
- Weir tanks, filter boxes are effective for removal of large particles such as sand
- Sand Media Filters are effective for removal of smaller particles such as sand and silt
- Filter bags can remove large particles until fabric pores start to fill in or cake over, then filter capacity increases to smaller sand and silt
- Filter bags must be placed in a heavily vegetated area to increase their efficiency or areas approved by the City Engineer
- Cartridge Filter Units will remove smaller particles such as silt and clay
- Rock Berms, Bio-filter Bags, or Sediment Fence shaped in a half circle and stages in a series of three can be installed as an alternate, or in conjunction with other systems

Inspection and Maintenance

- Ongoing inspection is necessary in order to detect any malfunctions or operation of equipment.
- Periodic inspection of discharge areas
- Remove sediment when it reaches 1/3 capacity of a sediment barrier
- Material must be placed in an approved location on site or exported from site

Diagram 4.2.9

SEDIMENT BAG

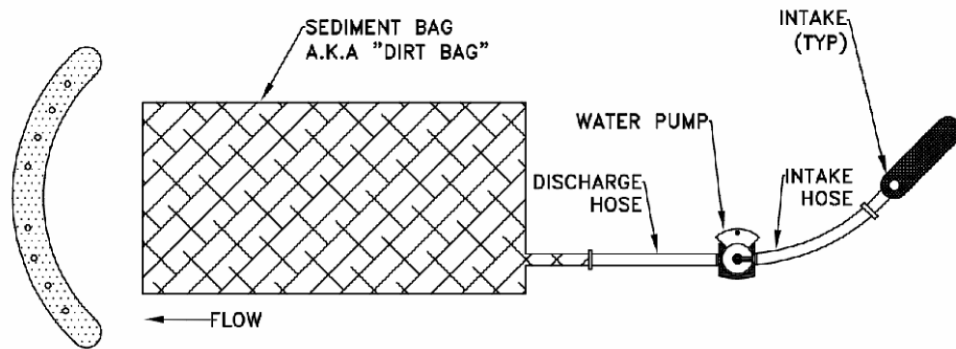

PLAN VIEW

NOTES:

1. THE SEDIMENT BAG SHALL BE MANUFACTURED USING A POLYPROPYLENE 8 OZ. NON-WOVEN GEOTEXTILE SEWN INTO A BAG WITH A DOUBLE NEEDLE, USING A HIGH STRENGTH THREAD.
2. EACH STANDARD SEDIMENT BAG MUST HAVE A FILL SPOUT LARGE ENOUGH TO ACCOMMODATE A 4" DISCHARGE HOSE, STRAPS ARE ATTACHED TO SECURE THE HOSE AND PREVENT PUMPED WATER FROM ESCAPING WITHOUT BEING FILTERED.
3. THE SEDIMENT BAG SHALL MEET OR EXCEED OVERALL BAG REMOVAL EFFICIENCY RATE OF 97.55%.
4. WATER BEING DISCHARGED FROM THE SEDIMENT BAG MUST BE FREE OF ALL SEDIMENT PRIOR TO LEAVING THE SITE OR ENTERING INTO THE STORM SYSTEM.
5. SEDIMENT BAG IS FULL WHEN IT NO LONGER CAN EFFICIENTLY FILTER SEDIMENT OR ALLOW WATER TO PASS AT A RATE LESS THAN 50% OF MANUFACTURER'S DESIGNED FLOW RATE.
6. DURING USE, THE SEDIMENT BAG MUST BE MONITORED.
7. DISPOSE OF USED SEDIMENT BAG OFF SITE OR AS APPROVED BY COA.
8. WHEN APPROPRIATE, INSTALL DOWNSTREAM SEDIMENT CONTROL MEASURES PER COA STANDARDS.
9. FOR BEST RESULTS, PLACE SEDIMENT BAG ON FLAT SURFACE.
10. SEDIMENT BAG SHOULD BE PLACED ON EXISTING VEGETATION, ROCK, OR BED OF STRAW. SEDIMENT BAG SHOULD NOT BE PLACED ON BARE GROUND.

4.2.10 **BMP 25: Sediment Trap**

A sediment trap consists of a small, temporary ponding area, with a rock weir or perforated riser pipe at the outlet, formed by excavation or by constructing a weir. The sediment trap serves drainage areas five acres and smaller. They are a retention structure designed to remove sediment from runoff by holding a volume of water for a length of time, allowing particles 0.02 mm and large to settle out. Sediment retention should be used with erosion prevention BMPs when included in a ESCP and never used by itself.

Combining with Permanent Drainage Facilities

- If a project includes a permanent stormwater retention/detention pond, the rough-graded or final-graded facility could function as a trap during construction. Design features of the permanent

- structure, such as surface area, retention time, and outlet control, should meet the design requirements of the temporary facility. Completion of the permanent facility would occur only when all upstream control structures are in place and stabilization of contributing drainage areas is complete.
- If a project includes an infiltration facility, the roughly excavated facility could be used as a trap or basin providing the facility provides the surface area and retention time required by the trap or basin. Excavate the sides and bottom of the facility to a minimum of three feet above final grade with a backhoe working at “arm’s length” to minimize disturbance and compaction of the infiltration surface.
 - Additionally, any required pretreatment facilities shall be fully constructed prior to any release of sediment-laden water to the facility. Pretreatment and shallow excavations are intended to prevent the clogging of soil with fines.

Advantages

- Protects downstream riparian properties from sediment deposits
- Prevents reduced downstream capacity due to sediment deposition in a stream channel
- Prevents clogging of downstream facilities
- Removes particles up to medium silt size (0.02 mm)
- Surface water conveyances can be connected to the facility as site development proceeds. The designer may want to route surface water collected from disturbed areas of the site through a sediment trap prior to release from the site.

Disadvantages

- May become an attractive nuisance. Care must be taken to adhere to all safety practices.
- Maintenance and sediment removal is essential for adequate performance
- Serves limited areas
- Does not reduce turbidity resulting from fine silts and clays in runoff. Traps are more effective when used in conjunction with other measures such as seeding and mulching.

Design Criteria

- Construct prior to any upslope clearing and grading
- Locate in a low area where the trap will intercept all or most of the runoff from the disturbed area before it enters a waterway, considering safety in case structure fails
- Locate the trap so that it is readily accessible for maintenance
- Provide for diversion dikes and ditches, as needed, to collect and divert water toward the trap. Sediment storage volume can be calculated using the USLE assuming a minimum one year sediment accumulation period for design purposes. To convert tons of sediment as calculated to cubic feet, multiply 0.05 tons per cubic foot.
- Determine the bottom surface area of the sediment trap using the calculated sediment volume and the maximum 1½ depth
- Determine the total trap dimensions by adding an additional two feet of depth for settling volume (before overtopping of spillway) above the sediment storage volume, while not exceeding 3:1 side slopes.
- Design the trap with a level bottom, 3:1 or flatter side slopes and a L:W ratio of 3
- Construct the trap as the first step in the clearing and grading of the site
- Form the trap by excavation or by construction of compacted embankment. If the trap is formed by embankment, the designer must note that dam safety regulation may apply to heights exceeding

five feet. The embankment must be stabilized using a cover method such as seeding, mulching, or erosion control matting.

- Water temperature in the trap may be too high for direct release. Always moderate the water temperature before it drains into a lake, stream, wetland, or waterway. Whenever possible, release the trap discharge onsite onto a relatively level, densely grassed area at least 50 feet from a waterway or wetland.
- Evaluate the release areas on a site-by-site basis to determine appropriate locations for and methods of releasing runoff. Do not use vegetated wetlands for this purpose.

Inspection and Maintenance

- Inspect once per week on active sites, once every two weeks on in-active sites, and within 24 hours following a 0.5-inch rain event
- Constant maintenance is essential for proper functioning.
- Remove sediment from the trap when it reaches one-third the storage capacity.
- Repair any damage to the trap, the embankments, or the slopes.

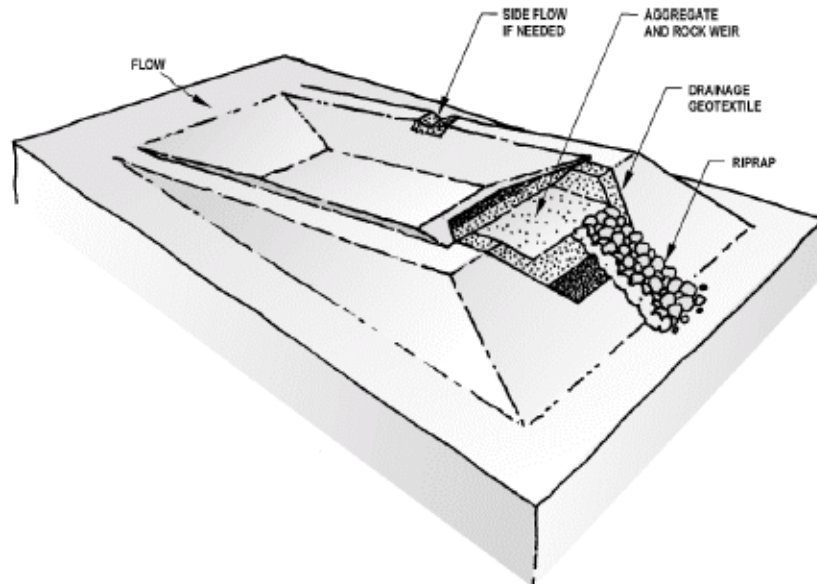
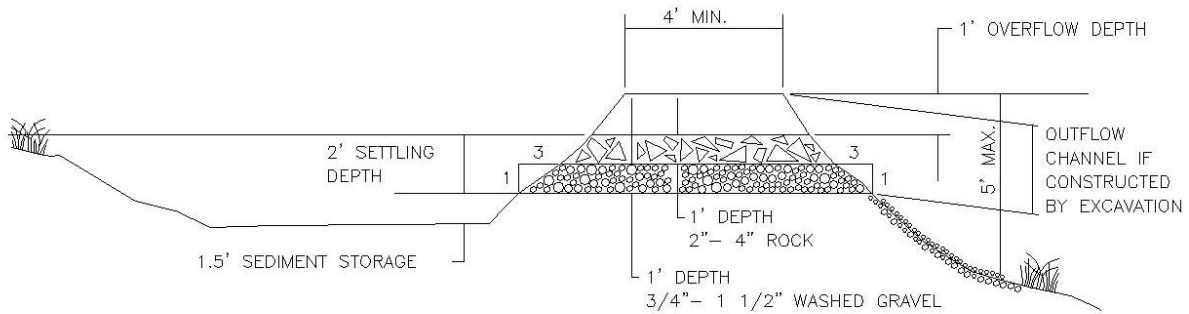

Diagram 4.2.10
SEDIMENT TRAP



CROSS SECTION

NTS

NOTE: MAY BE CONSTRUCTED BY EXCAVATION OR BY BUILDING A BERM.

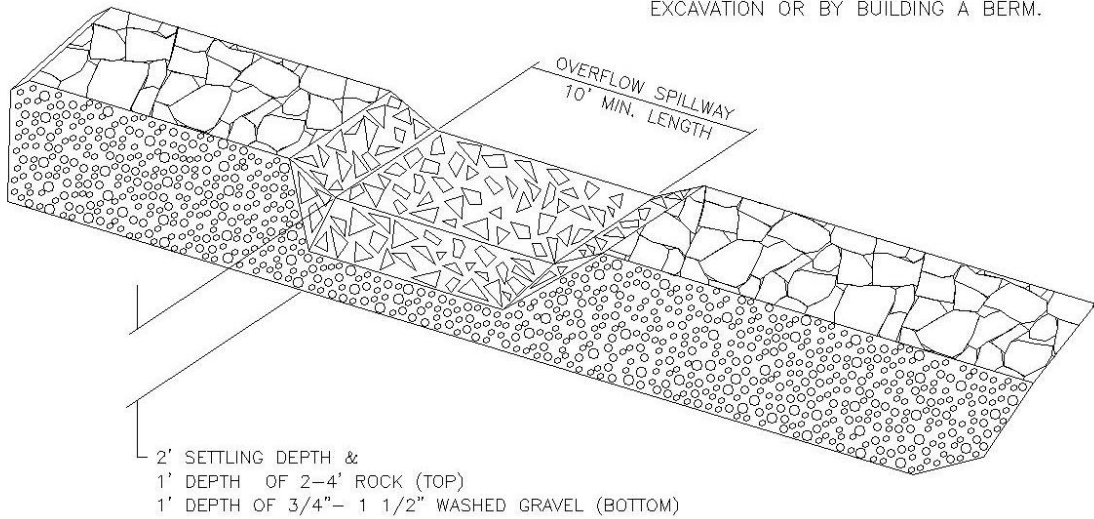

SEDIMENT TRAP OUTLET

NTS

NOTE:
 A FILTER FABRIC FENCE OR SIMILAR FILTER MUST BE CONSTRUCTED TO FILTER RUNOFF FROM THE SEDIMENT TRAP PRIOR TO DISCHARGE FROM THE CONSTRUCTION SITE.

4.2.11 **BMP 26: Sediment Basin**

A temporary sediment basin has one or more inflow points and baffles to spread the flow, wet and dry storage, a securely anchored riser pipe, a dewatering device, and an emergency overflow spillway. The sediment basin serves drainage areas of less than 10 acres and has a design life of approximately one year.

Basins are large facilities that treat runoff from large drainage areas. Because of this, basins have limited application on linear construction projects. The applications, advantages, and disadvantages of basins are included here for the designer's edification.

Combining with Permanent Drainage Facilities

- If a project includes a permanent stormwater retention/detention pond, the rough-graded or final-graded facility could function as a basin during construction. Design features of the permanent structure, such as surface area, retention time, and outlet control, should meet the design requirements of the temporary facility. Completion of the permanent facility shall occur only when all upstream control structures are in place and stabilization of contributing drainage areas is complete.
- If a project includes an infiltration facility, the roughly excavated facility could be used as a basin, providing the facility provides the surface area and retention time required by the basin. Excavate the sides and bottom of the facility to a minimum of two feet above final grade with a backhoe working at "arm's length" to minimize disturbance and compaction of the infiltration surface.
- Any required pretreatment facilities shall be fully constructed prior to any release of sediment-laden water to the facility. Pretreatment and shallow excavations are intended to prevent the clogging of soil with fines.

Advantages

- Protect downstream riparian properties from sediment deposits
- Prevent reduced downstream capacity due to sediment deposition in a stream channel
- Prevents clogging of downstream facilities
- Remove particles up to medium silt size 0.02 mm
- Surface water conveyances can be connected to the facility as site development proceeds

Disadvantages

- May become an attractive nuisance. Care must be taken to adhere to all safety practices.
- Failure of a basin which is not properly located could result in loss of life, damage to homes or buildings or interruption of services such as transportation or power.
- Maintenance and sediment removal is essential for adequate performance.
- Does not reduce turbidity resulting from fine silts and clays in runoff. Basins are more effective when used in conjunction with other measures such as seeding and mulching.

Design Criteria

- Water temperature in the basin may be too high for direct release. Always moderate the water temperature before it drains into a lake, stream, or waterway. Whenever possible, release the trap discharge onsite onto a relatively level, densely grassed area at least 50 feet from a waterway or wetland.
- Require installation of a staff gauge to aid in determining sediment depth
- The designer may want to route surface water collected from disturbed areas to a sediment basin prior to release from the site.

- A qualified engineer must design temporary sediment basins.

Inspection and Maintenance

- Inspect once per week on active sites, once every two weeks on in-active sites, and within 24 hours following a 0.5-inch rain event
- All damage caused by soil erosion or construction equipment shall be repaired before the end of each working day.
- Remove sediment when the sediment storage zone is half full. This sediment shall be placed in such a manner that it will not erode from the site. The sediment shall not be deposited downstream from the embankment or adjacent to a stream or floodplain.
- When temporary structures have served their intended purpose and the contributing drainage area has been properly stabilized, the embankments and resulting sediment deposit shall be leveled or otherwise disposed of in accordance with the approved erosion and sediment control plan.

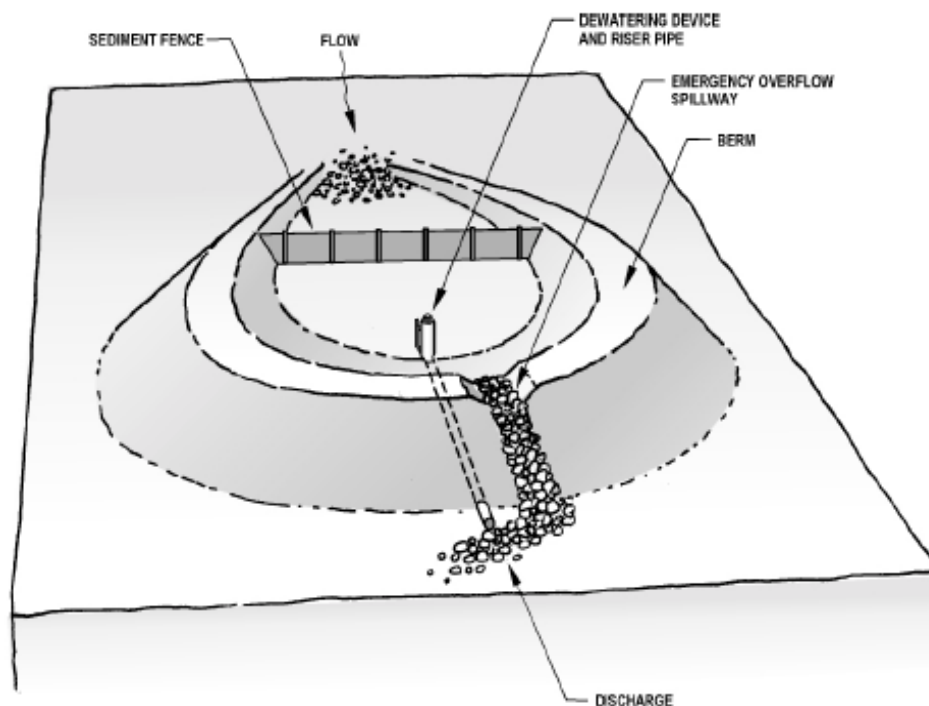
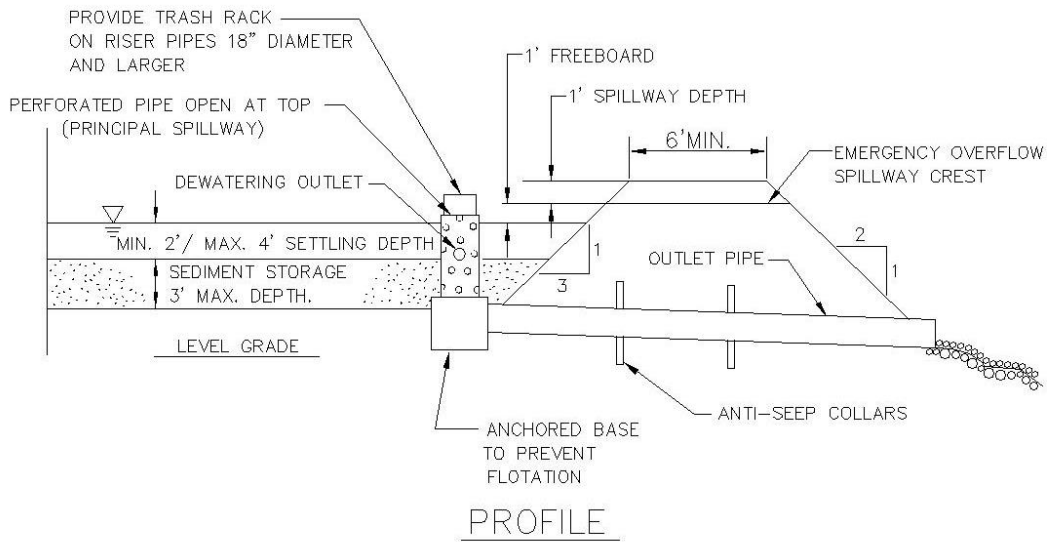
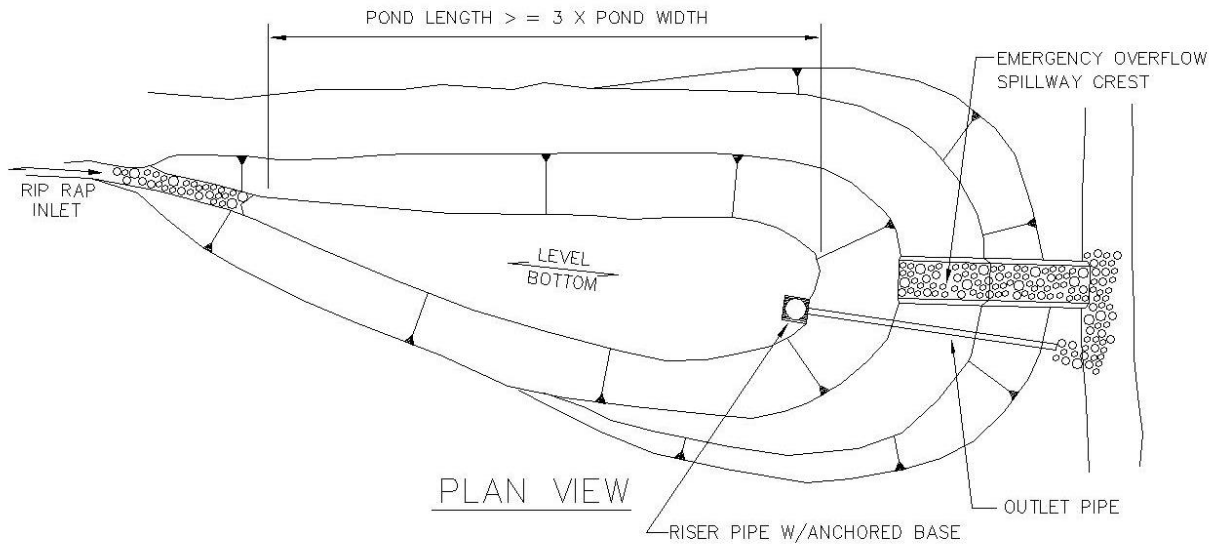

Diagram 4.2.11
SEDIMENT BASIN



NOTE:
 1. 50' MINIMUM OF HIGHLY VEGETATED AREA AND OR SEDIMENT FENCE IS REQUIRED PRIOR TO DISCHARGING TO STREAM OR WETLAND.

4.2.12 **BMP 27: Flocculants and Coagulants:**

Any use of Flocculants or Coagulants shall be submitted to DEQ with environmental Management Plan for approval prior to submittal of EPSC Plan to the City for approval.

Turbidity may be caused by silt and clay particulates which require an extended period of time to settle out due to their very small size, often much less than 0.001 mm in diameter. Removal of these colloidal suspension particles by settling alone is not practical. Polymers and inorganic chemicals additives speed the process of clarification by reacting with the particles. DEQ authorizes the use of cationic polymers that can be used as primary coagulants to reduce turbidity in stormwater. Inorganic chemicals such as aluminum or ferric sulfate and aluminum or ferric chloride can also be used. The added chemical destabilizes the suspension and causes the smaller particles to “floc” together as larger particles which settle more rapidly. The process consists of three steps: coagulation, flocculation, and settling or clarification.

Advantages

- Increased removal of turbidity
- Variety of additives and setups
- Customizable to job sites

Disadvantages:

- Increased onsite testing and sampling for TSS and pH
- Additional design for flows, volume and application rate of additive
- Typically requires large area for settling tank or pond
- Only way to determine if additive works is to take samples and test
- Additional Cost for additives and system
- Secondary Treatment for by-products of certain additives as needed

Inspection and Maintenance:

- Inspect daily when in use to verify system is functioning
- Sample and test system discharge TSS and pH when system is in use
- Make sure Compost Filter Socks are in contact with the surface it is installed on
- Inspect settling tank or pond weekly. Remove sediment when the sediment storage zone is half full. This sediment shall be placed in such a manner that it will not erode from the site. The sediment shall not be deposited downstream from the embankment or adjacent to a stream or floodplain.

4.2.13 **BMP 28: Construction Entrance**

A construction entrance consists of a stabilized rock pad placed at construction site ingress/egress locations that reduces the amount of sediment transported onto paved roads by vehicles or runoff. The Construction Entrance also includes a curb ramp designed out of wood.

Advantages

- Reduces traffic hazards caused by debris on public roadways
- Reduces sediment and other debris from entering roadways, which can then be washed into the storm

Disadvantages

- Only effective if erosion and sediment control employed elsewhere onsite
- Only works if installed at every location where significant construction traffic leaves the site
- Fills with sediment quickly and requires frequent maintenance and/or replacement of rock

Design Criteria

- Install construction entrance prior to any site work
- Whenever possible, construct the pad on a firm, compacted subgrade
- Install geotextile under rock when subgrade is not stable or is “pumping” up into the pad
- **Minimum length:**
 - 20 feet - all single-family sites
 - 50 feet – all other development sites
- **Minimum width:**
 - 20 feet – all construction sites
- **Minimum Depth:**
 - 8 inches – all construction sites
- **Rock Size:**
 - 1” minus – all single-family sites
 - 3”-6” – all other construction sites
- Do not install rock on paved surfaces. (Use wood curb ramps.)
- Wood Curb ramps should be made out of 2 × 6 material, nailed together
- Include a tire wash facility if the entrance does not prove effective in retaining sediment onsite

Inspection and Maintenance

- Requires ongoing inspection
- Immediately sweep up and remove or stabilize onsite any sediment that is tracked onto pavement
- If the sediment poses a threat to public safety and street sweeping proves ineffective, consider washing the street and collecting the water in a sediment pond or sump before it leaves the site.
- Add or replace rock as needed to maintain the specified dimensions
- Immediately remove any rock, which gets carried from the pad to the roadway.
- Replace rock when void space is filled with sediment

Diagram 4.2.13
CONSTRUCTION ENTRANCE

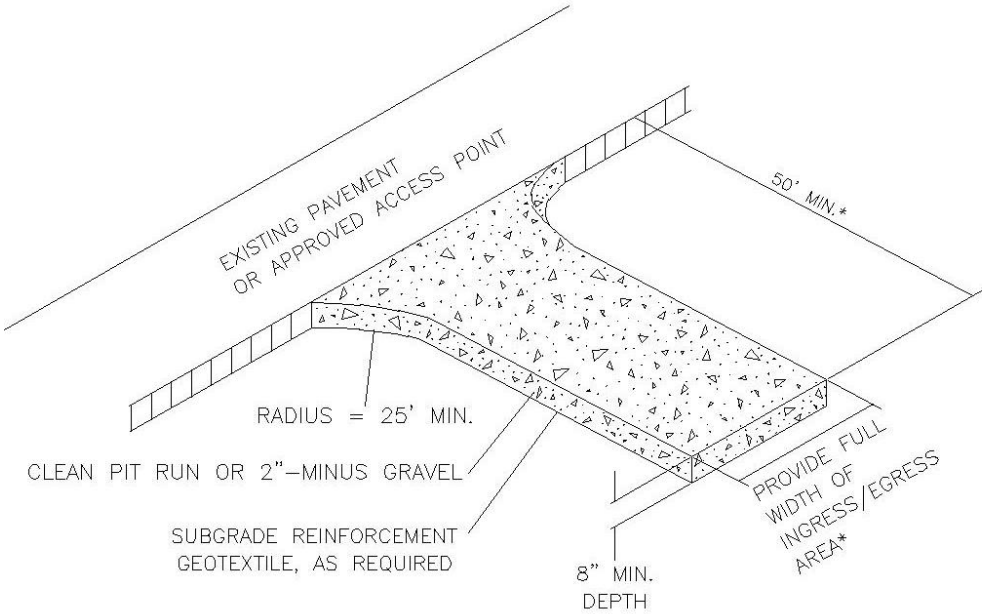

*20' MIN. FOR SINGLE FAMILY AND DUPLEX RESIDENTIAL

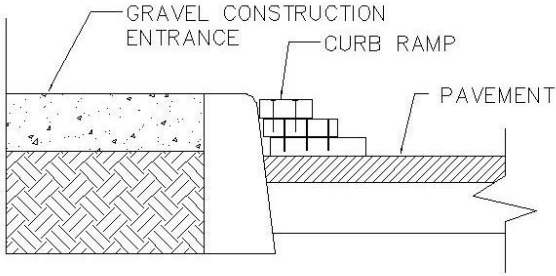

- NOTES:
DIMENSIONS
SINGLE FAMILY
 20' LONG BY 20' WIDE
 8" DEEP OF ¾" MINUS CLEAN ROCK.
COMMERCIAL
 50' LONG BY 20' WIDE
 3-6" CLEAN ROCK,
 GOVERNING AUTHORITY MAY REQUIRE
 GEOTEXTILE FABRIC TO PREVENT
 SUB-SOIL PUMPING.

4.2.14 **BMP 29: Tire Wash Facility**

Two types of tire wash facilities are available depending on the severity of sediment tracking and the size and duration of project. Type 1 can be retrofitted in the field, using geotextile fabric and rock. Like a stabilized construction entrance, it is graded so collected wash water is conveyed to a sediment trap, basin, or other suitable treatment facility. Type 2 consists of a shallow concrete-lined basin partially filled with water, through which exiting vehicles drive.

Advantages

- Reduces traffic hazards caused by debris on public roadways
- Reduces sediment on roadways, which can wash into the storm sewer system
- Type 1 is easy to construct and is relatively inexpensive
- Type 2 is useful for high traffic volumes or large projects of long duration

Disadvantages

- Only works if installed at every location where construction traffic leaves the site
- Fills with sediment quickly and requires frequent maintenance
- Requires a source of wash water
- Requires a turnout or doublewide exit to avoid entering vehicles having to drive through wash area
- Type 2 is costly to construct
- Both facilities will generate large volumes of sediment-laden water, requiring treatment elsewhere on site

Design Criteria

Type 1 (temporary)

- Minimum length: 40 feet
- Minimum width: 10 feet
- Minimum rock depth: 8 inches
- Average tire wash sump: 18 inches
- Install subgrade geotextile fabric as a liner
- Use 4"-6" rock over geotextile fabric
- **Alternate:** 3" asphalt lift over a stable base coarse
- Grade the pad to drain to suitable collection and treatment facility
- Install fencing as necessary to restrict exiting construction vehicle traffic to the tire wash

Type 2 (permanent)

- Minimum length: 40 feet with sloping ingress and egress
- Minimum width: 10 feet
- Minimum rock depth: 8 inches
- Average tire wash sump: 18 inches
- Run out impervious area should be a minimum of 50 feet, graded back to facility
- Line bottom of basin with geotextile and 12 inches of rock base coarse
- Construct basin out of 12" concrete with steel reinforcement
- Provide water supply
- Provide outlet for sediment-laden water discharge to treatment facility or provide pumps and tanks for water treatment

Inspection and Maintenance

- Inspect weekly minimum, or more frequently depending upon use

Type 1

- Clean or replace rock clogged with sediment
- Re-grade rock as needed
- Maintain tire wash sump depth
- Maintain a clean run-out pad
- Immediately remove any rock that gets carried from the pad to the roadway
- Ensure that wash water drainage, collection and treatment system is functioning

Type 2

- Remove/discharge wash water as needed
- Remove accumulated sediment from tire wash facility in order to maintain tire wash sump
- Ensure that wash water collection and treatment system is functioning

Diagram 4.2.14
TIRE WASH FACILITY

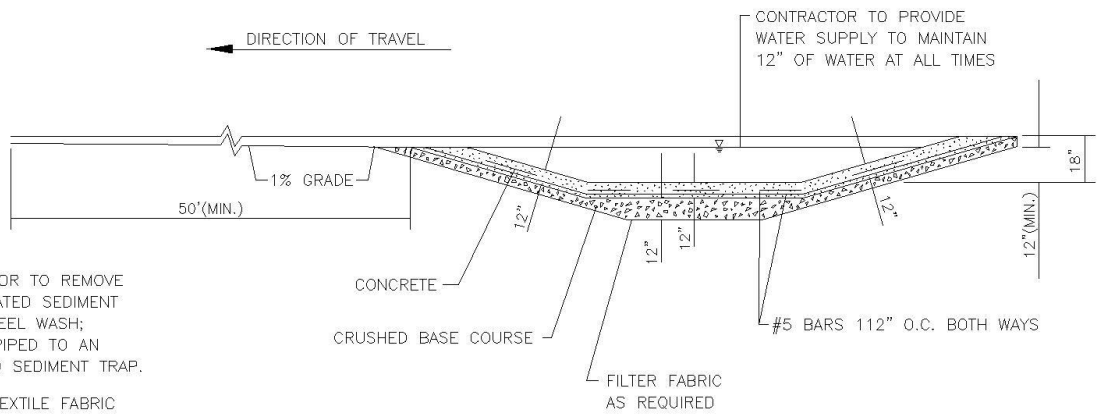
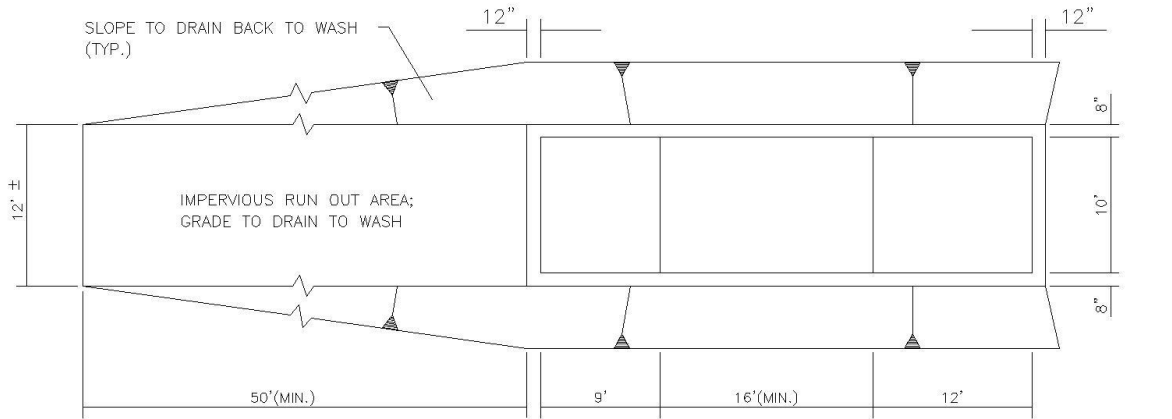

NOTES:

1. CONTRACTOR TO REMOVE ACCUMULATED SEDIMENT FROM WHEEL WASH; MAY BE PIPED TO AN APPROVED SEDIMENT TRAP.
2. USE GEOTEXTILE FABRIC WITH AGGREGATE FOR A TEMPORARY TIRE WASH.

CHAPTER 5: POLLUTION PREVENTION HOUSEKEEPING BEST MANAGEMENT PRACTICES

5.1 Management of Other Construction Site Pollutants

There are numerous potential pollutants, other than erosion and sediment, associated with construction activities that may impact stormwater. Potential pollutants include pollutants associated with the use of concrete and other cement-related mortars and the handling, application, and disposal of construction products and chemicals such as paints, adhesives, and solvents. The improper use and handling of construction materials can result in wash water, spills, or waste being left on the ground. These chemicals can infiltrate into soils causing groundwater contamination or wash-off to surface waters during subsequent storms. Housekeeping BMPs are intended to prevent pollutants from contact with exposed soils and coming into contact with stormwater runoff.

Although this manual is not intended to address all aspects of construction site pollution control, some issues overlap with erosion and sediment control and must be taken into account in the overall planning process.

At a minimum the contractor must provide pollution prevention for:

- off-site tracking of soils
- material management
- waste management
- vehicle and equipment management

Each construction project is unique, and understanding the pollution risks for each construction activity is essential to successfully selecting and implementing pollution control BMPs. Defining these risks requires careful review of the site characteristics and the nature of the construction project. Once these risks are defined, BMP objectives can be developed and pollution control BMPs selected. In general, the pollution control BMP objectives for construction projects are as follows:

- **Practice Good Housekeeping** – Perform activities in a manner which keeps potential pollutants from either draining or being transported off-site by managing pollutant sources and modifying construction activities.
- **Contain Waste** – Dispose of all construction waste in designated areas and keep stormwater from flowing on or off of these areas.

Table 5-1 presents disposal and management alternatives for typical potential pollutants associated with construction activities.

Table 5-1 Quick Reference for Pollution Control

Discharge/Activity	BMP Detail No.	BMP/Pollution Control
Painting & Paint Removal		
Excess paint	36, 32, 33	<i>Oil Based</i> 1. Recycle/reuse. 2. Dispose as hazardous waste. <i>Water Based</i> 1. Recycle/reuse. 2. Dry residue in cans, dispose as trash. If volume is too much to dry, dispose as hazardous waste.
Paint cleanup	32, 37	Wipe paint out of brushes, then: <i>Oil Based</i> 3 Filter and reuse thinners, solvents. 4 Dispose of as hazardous waste. <i>Water Based</i> 1. Rinse to sanitary sewer.
Paint stripping (with solvent)	32	5. Dispose as hazardous waste.
Non-hazardous paint scraping/sand blasting	32	6. Dry sweep, dispose as trash.
HAZARDOUS paint scraping/sand blasting (e.g. marine paints or paints containing lead or tributyl tin)	32, 37	7. Dry sweep, dispose as hazardous waste.
General Construction		
Soil from excavations during wet weather periods or forecasted rain	38	1. Cannot be placed in the street, on paved areas or near waterways. 2. Remove from site or backfill by end of day. 3. Cover with tarpaulin or surround with sediment barrier or use other runoff controls (see Chapter 4). 4. Place inlet protection over storm drain inlets. Note: Thoroughly sweep following removal of dirt in all four alternatives.

Table 5-1 Quick Reference for Pollution Control

Discharge/Activity	BMP Detail No.	BMP/Pollution Control
Soil from excavations placed on paved surfaces during dry season	38	8. Keep materials out of storm conveyance systems and thoroughly remove via sweeping. Cover to prevent wind erosion.
Cleaning streets in construction areas	36	9. Dry sweep 10. Use silt ponds, inlet protection and/or similar sediment control techniques when flushing pavement.
Soil erosion, sediments	(see Chapter 4)	11. Cover disturbed soils, use erosion controls, block entry to storm drain 12. Seed or plant as soon as possible
Fresh cement, grout, mortar	39	13. Use/reuse excess 14. Dispose to trash 15. Do not allow into surface water and/or collection systems
Wash water from concrete/mortar(etc.) cleanup	39	16. Wash onto dirt area and spade in 17. Pump and remove to appropriate disposal facility 18. Settle; pump water to vegetated area at least 150 feet from surface water.
Rinse water from concrete mixing trucks	39	19. Return truck to yard for rinsing into settling pond or dirt area. 20. At construction site, concrete wash into designated area, never allow into storm sewer or waterways.
Rinse water from paint sprayers	32	21. At construction site, wash into designated area for containment then remove from site.
Non-hazardous construction and demolition debris	36	22. Recycle/reuse (concrete, wood, etc.) 23. Dispose as trash
Hazardous demolition and construction debris (e.g., asbestos).	37	24. Dispose as hazardous waste
Concrete saw-cut slurry (wet sawing)	39	25. Use dry cutting technique and sweep up residue 26. Place a berm on down-slope side of project to collect slurry before it flows off site 27. Vacuum slurry and dispose off-site 28. Shovel out gutters; dispose residue to dirt area, construction yard or landfill 29. Block all storm drains or curb inlets

Table 5-1 Quick Reference for Pollution Control

Discharge/Activity	BMP Detail No.	BMP/Pollution Control
Construction dewatering (non-turbid, uncontaminated groundwater)	30	30. Recycle/reuse. 31. Discharge to storm drain after receiving City approval 32. Settle, pump water to sanitary sewer or vegetated area at least 50 yards from surface water. Discharge to sanitary sewer may require a permit from the POTW.
Construction dewatering (other than non-turbid, uncontaminated groundwater)	30	33. Recycle/reuse 34. Discharge to filtration system 35. As approved, treat prior to discharge to storm drain, requires NPDES permit.
Leaks from garbage dumpsters	35	36. Collect, contain leaking material. Eliminate leak, keep covered, return to leasing company for immediate repair 37. If dumpster is used for liquid waste, use plastic liner.
Leaks from construction debris bins	35, 33	38. Ensure bins are used for dry nonhazardous materials only. (Suggestion: fencing, covering helps prevent misuse).
Dumpster cleaning water	35	39. Clean at dumpster owner's facility and discharge waste through grease interceptor to sanitary sewer. 40. Clean on site and discharge through grease interceptor to sanitary sewer.
Cleaning driveways, paved areas	35	1. Sweep and dispose of as trash (dry cleaning only). 2. For vehicle leaks, follow this 3-step process: a. Clean up leaks with rags or absorbents b. Sweep, using granular absorbent material (cat litter) c. Mop and dispose of mop water to sanitary sewer
Paving Operations	31	41. Avoid paving during wet weather 42. Protect drainage systems by diverting runoff or trap/ filter system 43. Place drip pans or absorbent materials under paving equipment when not in use

Table 5-1 Quick Reference for Pollution Control

Discharge/Activity	BMP Detail No.	BMP/Pollution Control
Steam cleaning of sidewalks, plazas	35	44. Collect all water and properly dispose of; do not allow runoff to enter storm sewer. 45. Follow this 3-step process: a. Clean oil leaks with rags or absorbents b. Sweep (use dry absorbent as needed) c. Use no soap, discharge to storm drain
Aggregate wash from driveway/patio construction	35	1. Wash onto dirt area, spade in 2. Pour driveway approach last 3. Collect and remove to appropriate disposal facility 4. Settle, pump water to vegetated area at least 150 feet from surface water
Portable Toilets	44	5.
Landscape/Garden Maintenance		
Pesticides	34, 37, 44	46. Use all material in container. Rinse containers use rinse water as product. 47. Dispose rinsed containers as trash 48. Dispose unused pesticide as hazardous waste
Fertilizer applications	34, 37, 44	49. Sweep any “over spray” material from streets, sidewalks and driveways
Yard & garden clippings	36	50. Compost 51. Take to landfill
Tree trimming	36	52. Chip if necessary, before composting or recycling.
Vehicle/Equipment Wastes		
Used motor oil & oil filters	43, 35, 33, 37	53. Use secondary containment while storing, send to recycler
Antifreeze	43, 35, 33, 37	54. Use secondary containment while storing, send to recycler
Other vehicle fluids and solvents	43, 35, 33, 37	55. Dispose as hazardous waste
Automobile batteries	43, 33, 37	56. Use secondary containment while storing 57. Send to auto battery recycler 58. Take to recycling center

Table 5-1 Quick Reference for Pollution Control

Discharge/Activity	BMP Detail No.	BMP/Pollution Control
Vehicle washing	41, 44	59. Wash on pervious surface and use cold water only. 60. Never allow runoff to directly discharge to storm drainage systems.
Mobile vehicle washing	41	61. Collect wash water and discharge to sanitary sewer w/ City approval; never allow wash water to discharge to storm drainage systems.
Rinse water from dust removal at new car fleets	41	62. If rinsing dust from exterior surfaces for appearance purposes, do not use soap (cold water only).
Vehicle leaks & equipment fueling	35, 42, 43	63. Clean up leaks with rags or absorbents. 64. Sweep, using granular absorbent material (cat litter). Fuel only in designated area and place a spill kit in the fueling area.
Other Wastes		
Roof drains		65. If roof is contaminated with industrial waste products, discharge to sanitary sewer with approval from local sanitary authority (may need a discharge permit). 66. If no contamination is present, discharge to pervious surface.
Cooling water Air conditioning condensate		67. Recycle/reuse 68. Discharge permit may be required, contact local sanitary authority.
Pumped groundwater, infiltration/foundation drainage (contaminated)		69. Recycle/reuse (landscaping, etc.) 70. Discharge permit may be required, contact local sanitary authority.
Firefighting flows		71. If contamination is present, fire department will attempt to prevent flow to stream or storm drainage system.
Clean-up wastewater from sewer back-up		Follow this procedure: a. Block storm drain, contain, collect, and return spilled material to the sanitary sewer. b. Block storm drain; rinse remaining material to collection point and pump to sanitary sewer. (No rinse water may flow to storm drain.)

5.2 Pollution Control BMPs

This chapter describes specific BMPs for common construction activities that may pollute stormwater. The following fact sheets were adapted from the Construction Methods Handbook developed in 1993 by California's Stormwater Quality Task Force and are suitable for inclusion in erosion and sediment control (EPSC) plans or Pollution Control Plans (PCP) for typical contractor activities. The BMPs listed are not an exhaustive list, nor will every BMP be appropriate for every situation. Therefore, the suggested BMPs that are inappropriate may be deleted and additional BMPs for specific site conditions should be added. In addition, the selection and implementation of BMPs should be reviewed on a regular basis to match the changing conditions at construction sites.

The following fact sheets have been included.

Target Pollutants and Impact Significance

H = High M = Medium L/U = Low or Unknown

BMP Number and Title	Sediment	Nutrients	Toxic Materials	Oil and Grease	Floatable Materials	Other Constr. Waste
1 Dewatering Operations	H	L/U	M	L/U	L/U	L/U
2 Paving Operations	M	L/U	M	M	L/U	L/U
3 Structure Construction and Painting	L/U	L/U	M	L/U	H	H
4 Material Delivery and Storage	M	M	M	M	M	L/U
5 Material Use	L/U	M	M	M	M	L/U
6 Spill Prevention and Control	L/U	L/U	M	M	L/U	L/U
7 Solid Waste Management	M	L/U	L/U	L/U	H	H
8 Hazardous Waste Management	L/U	L/U	M	L/U	L/U	L/U
9 Contaminated Soil Management	M	L/U	M	L/U	L/U	L/U
10 Concrete Waste Management	M	L/U	L/U	L/U	L/U	M
11 Vehicle and Equipment Cleaning	M	L/U	M	M	L/U	L/U
12 Vehicle and Equipment Fueling	L/U	L/U	M	M	L/U	L/U
13 Vehicle and Equipment Maintenance	L/U	L/U	M	M	L/U	L/U
14 Employee and Subcontractor Training						

5.2.1 **BMP 30: Dewatering Operations**

Description

Prevent or reduce the discharge of pollutants to stormwater from dewatering operations by using sediment controls and by testing the groundwater for pollution.

Approach

There are two general classes of pollutants that may result from dewatering operations: sediment and toxic products (including petroleum products). High sediment content in dewatering discharges is common because of the nature of the operation. On the other hand, toxins and petroleum products are not commonly found in dewatering discharges unless the site or surrounding area has been used for industrial activities, or the area has a history of groundwater contamination. The following steps will help reduce stormwater pollution from dewatering discharges:

Sediment

- Use sediment controls to remove sediment from water generated by dewatering.
- Use filtration to remove sediment from a sediment trap or basin. Filtration can be achieved with:
 - Sump pit and a perforated or slit standpipe with holes and wrapped in filter fabric. The standpipe is surrounded by stones, which filter the water as it collects in the pit before being pumped out. Wrapping the standpipe in filter fabric may require an increased suction inlet area to avoid clogging and unacceptable pump operation.
 - Floating suction hose to allow cleaner surface water to be pumped out.

Toxic Products (including Petroleum Products)

- In areas suspected of having groundwater pollution, sample the groundwater near the excavation site and have the water tested for known or suspected pollutants at a certified laboratory. Check with the Department of Environmental Quality (DEQ) and the local wastewater treatment plant for their requirements for dewatering, additional water quality tests, and disposal options.
- With a permit, you may be able to recycle/reuse pumped groundwater for landscape irrigation, or discharge to the storm sewer. With a permit from the DEQ and/or a approval of the City of Albany Director of Public Works, you may be able to treat pumped groundwater and discharge it to the municipal wastewater treatment plant via the sanitary sewer.
- For a quick reference on disposal alternatives for specific wastes, see Table 5-1, Quick Reference – Disposal Alternatives.

5.2.2 **BMP 31: Paving Operations**

Description

Prevent or reduce the discharge of pollutants from paving operations, using measures to prevent run-on and runoff pollution, properly disposing of wastes, and training employees and subcontractors.

Approach

- Avoid paving during wet weather.
- Store materials away from drainage courses to prevent stormwater run-on (see BMP 4, Material Delivery and Storage).
- Protect drainage courses, particularly in areas with a grade, by employing BMPs to divert runoff or trap/filter sediment.
- Leaks and spills from paving equipment can contain toxic levels of heavy metals and oil and grease. Place drop pans or absorbent materials under paving equipment when not in use. Clean up spills

- with absorbent materials rather than burying. See BMP 42 (Vehicle and Equipment Maintenance) and BMP 35 (Spill Prevention and Control) in this chapter.
- Cover catch basins and manhole when applying seal coat, track coat, slurry seal, fog seal, etc.
- Shovel or vacuum saw cut slurry and remove from site. Cover or barricade storm drains during saw cutting to contain slurry.
- If paving involves Portland Cement Concrete, see BMP 39 (Concrete Waste Management).
- If paving involves asphaltic concrete, the following precautions may help prevent pollutant from entering stormwater:
 - Do not allow sand or gravel placed over new asphalt to wash into storm drains, streets, or creeks by sweeping. Properly dispose of this waste by referring to BMP 7 (Solid Waste Management) in this chapter.
 - Old asphalt must be disposed of properly. Collect and remove all broken asphalt from the site and recycle whenever possible.
 - If paving involves on-site mixing plant, follow the stormwater permitting requirements for industrial activities.
- Train employees and subcontractors

5.2.3 **BMP 32: Painting**

Description

Prevent or reduce the discharge of pollutants to stormwater from structure construction and painting by enclosing or covering or berming building material storage areas, using good housekeeping practices, using safer alternative products, and training employees and subcontractors.

Approach

- Keep the work site clean and orderly. Remove debris in a timely fashion. Sweep the area.
- Use soil erosion control techniques if bare ground is exposed.
- Buy recycled or less hazardous products to the maximum extent practicable.
- Conduct painting operations consistent with local air quality and OSHA regulations.
- Properly store paints and solvents. See BMP 33 (Material Delivery and Storage) in this chapter.
- Properly store and dispose of waste materials generated from the activity. See the waste management BMPs (BMP 36 to BMP 39) in this chapter.
- Recycle residual paints, solvents, lumber, and other materials to the maximum extent practical.
- Make sure that nearby storm drains are well marked to minimize the chance of inadvertent disposal of residual paints and other liquids.
- Clean the storm drain in the immediate construction area after construction is completed.
- Educate employees who are doing the work.
- Inform subcontractors of company policy on these matters and include appropriate provisions in their contract to make certain proper housekeeping and disposal practices are implemented.
- For a quick reference on disposal alternatives for specific wastes, see Table 5-1.
- Paint Sprayers wash into designated area with secondary containment then remove from site. Secondary containment shall be a container or a lined facility for discharge.

5.2.4 **BMP 33: Material Delivery and Storage**

Description

Prevent or reduce the discharge of pollutants to stormwater from material delivery and storage by minimizing the storage of hazardous materials on-site, storing materials in a designated area, installing secondary containment, conducting regular inspection, and training employees and subcontractors.

The best management practice covers only material delivery and storage. For other information on materials, see BMP 34 (Material Use), or BMP 35 (Spill Prevention and Control). For information on wastes, see the waste management BMPs in this chapter.

Approach

The following materials are commonly stored on construction sites:

- Soil
- Pesticides and herbicides
- Fertilizers
- Detergents
- Plaster or other products
- Petroleum products such as fuel, oil, and grease
- Other hazardous chemicals such as acids, lime, glues, paints, solvents, and curing compounds

Storage of these materials on-site can pose the following risks:

- Stormwater pollution
- Injury to workers or visitors
- Groundwater pollution
- Soil contamination

The following steps must be taken to minimize risk of pollution:

- Designate areas of the construction site for material delivery and storage.
 - Place near the construction entrances, away from waterways
 - Avoid transport near drainage paths or waterways
 - Surround with earth berms
 - Place in an area that will be paved
- Storage of reactive, ignitable, or flammable liquids must comply with the fire codes for your area. Contact the local Fire Marshal to review site materials, quantities, and proposed storage area to determine specific requirements.
- For a quick reference on disposal alternatives for specific wastes, see Table 5-1, Quick Reference – Disposal Alternatives.
- Keep an accurate, up-to-date inventory of materials delivered and stored on-site.
- Keep your inventory down.
- Minimize hazardous materials on-site storage.
- Handle hazardous materials as infrequently as possible.
- During the rainy season, consider storing materials in a covered area. Store materials in secondary containments such as an earthen dike, horse trough, or even a child's wading pool for non-reactive materials such as detergents, oil, grease, and paints. Small amounts of material may be secondarily contained in "bus boy" trays or concrete mixing trays.
- Do not store chemicals, drums, or bagged materials directly on the ground. Place these items on a pallet and, when possible, in secondary containment.
- If drums must be kept uncovered, store them at a slight angle to reduce ponding of rainwater on the lids and to reduce corrosion.
- Try to keep chemicals in their original containers and keep them well labeled.
- Train employees and subcontractors.

- Employees trained in emergency spill cleanup procedures must be present when dangerous materials or liquid chemicals are unloaded.
- If significant residual materials remain on the ground after construction is complete, properly remove materials and any contaminated soil (See BMP 38). If the area is to be paved, pave as soon as materials are removed to stabilize the soil.

5.2.5 **BMP 34: Material Use**

Description

Prevent or reduce the discharge of pollutants to stormwater from material use by using alternative products, minimizing hazardous material use on-site, and training employees and subcontractors.

Approach

The following materials are commonly used on construction sites:

- Pesticides and herbicides
- Fertilizers
- Detergents
- Plaster or other products
- Petroleum products such as fuel, oil, and grease
- Other hazardous chemicals such as acids, lime, glues, paints, solvents, and curing compounds.

Use of these materials on-site can pose the following risks:

- Stormwater pollution
- Injury to workers or visitors
- Groundwater pollution
- Soil contamination

The following steps must be taken to minimize the risk:

- Use less hazardous, alternative materials as much as possible
- Minimize use of hazardous materials on-site
- Use materials only where and when needed to complete the construction activity
- Follow manufacturer's instructions regarding uses, protective equipment, ventilation, flammability, and mixing of chemicals.
- Personnel who use pesticides must be trained in their use.
- Do not over-apply fertilizers, herbicides, and pesticides. Prepare only the amount needed. Follow the recommended usage instructions. Over-application is expensive and environmentally harmful. Unless on steep slopes, till fertilizers into the soil rather than hydroseeding. Apply surface dressings in several smaller applications, as opposed to one large application, to allow time for infiltration and to avoid excess material being carried off-site by runoff. Do not apply these chemicals just before it rains.
- Train employees and subcontractors in proper material use.

5.2.6 **BMP 35: Spill Prevention and Control**

Description

Prevent or reduce the discharge of pollutants to stormwater from leaks and spills by reducing the chance for spills, stopping the source of spills, containing and cleaning up spills, properly disposing of spill materials, and training employees.

This BMP covers only spill prevention and control. However, BMP 33 (Material Delivery and Storage) and BMP 34 (Material Use), also contain useful information, particularly on spill prevention. For information on wastes, see the waste management BMPs in this chapter.

Approach

The following steps will help reduce the stormwater impacts of leaks and spills:

Define “Significant Spill”

- Different materials pollute in different amounts. Make sure each employee knows what a “significant spill” is for each material they use, and what is the appropriate response for “significant” and “insignificant” spills.

General Measures

- Hazardous materials and wastes must be stored in covered containers and protected from vandalism.
- Place a stockpile of spill cleanup materials where it will be readily accessible
- Train employees in spill prevention and cleanup
- Designate responsible individuals

Cleanup

- Clean up leaks and spills immediately
- On paved surfaces, clean up spills with as little water as possible. Use a rag for small spills, a damp mop for general cleanup, and absorbent material for larger spills. If the spilled material is hazardous, then the used cleanup materials are also hazardous and must be sent to either a certified laundry (rags) or disposed of as hazardous waste.
- Never hose down or bury dry material spills. Clean up as much of the material as possible and dispose of properly. See the waste management BMPs in this chapter for specific information.

Reporting

- Report significant spills to local agencies, such as the Public Works Department Environmental Services Division (541) 917-7631.
- Federal regulations require that any significant oil spill into a water body or onto an adjoining shoreline be reported to the National Response Center (NRC) at 800-424-8802 (24 hour).

Use the following measures related to specific activities:

Vehicle and Equipment Maintenance

- If maintenance must occur on-site, use a designated area and /or a secondary containment, located away from drainage courses, to prevent the run-on of stormwater and the runoff of spills.
- Regularly inspect on-site vehicles and equipment for leaks, and repair immediately.
- Check incoming vehicles and equipment (including delivery trucks and employee and subcontractor vehicles) for leaking oil and fluids. Do not allow leaking vehicles or equipment on-site.
- Always use secondary containment, such as a drain pan or drop cloth, to catch spills or leaks when removing or changing fluids.
- Place drip pans or absorbent materials under paving equipment when not in use.
- Use adsorbent materials on small spills rather than hosing down or burying the spill. Remove the adsorbent materials promptly and dispose of properly.

- Promptly transfer used fluids to the proper waste or recycling drums. Do not leave full drip pans or other open containers lying around.
- Oil filters disposed of in trashcans or dumpsters can leak oil and pollute stormwater. Place the oil filter in a funnel over a waste oil-recycling drum to drain excess oil before disposal. Oil filters can also be recycled. Ask your oil supplier or recycler about recycling oil filters.
- Store cracked batteries in a non-leaking secondary container. Do this with all cracked batteries, even if you think all the acid has drained out. If you drop a battery, treat it as if it is cracked. Put it into the containment area until you are sure it is not leaking.

Vehicle and Equipment Fueling

- If fueling must occur on-site, use designated areas, located away from drainage courses, to prevent the run-on of stormwater and the runoff of spills.
- Discourage “topping-off” of fuel tanks; an increase in temperature can cause fuel to expand and overflow.
- Always use secondary containment such as a drain pan to catch when fuel spills/leaks.

5.2.7 **BMP 36: Solid Waste Management**

Description

Prevent or reduce the discharge or pollutants to stormwater from solid or construction waste by providing designated waste collection areas and containers, arranging for regular disposal, and training employees and subcontractors.

Approach

Solid waste is one of the major pollutants resulting from construction. Construction debris includes:

- Solid waste generated from trees and shrubs removed during land clearing, demolition or existing structures (rubble), and building construction
- Packaging materials including wood, paper and plastic
- Scrap or surplus building materials including scrap metals, rubber, plastic, glass pieces, and masonry products
- Domestic wastes including food containers such as beverage cans, coffee cups, paper bags, plastic wrappers, and cigarettes

The following steps will help keep a clean site and reduce stormwater pollution:

- Select designated waste collection areas on-site
- Inform trash-hauling contractors that you will accept only watertight dumpsters for on-site use. Inspect dumpsters for leaks and repair any dumpster that is not watertight
- Locate containers in a covered area and/or in a secondary containment
- Provide an adequate number of containers with lids or covers that can be placed over the container to keep rain out or to prevent loss of wastes when it is windy
- Plan for additional containers and more frequent pickup during the demolition phase of construction.
- Collect site trash daily, especially during raining and windy conditions
- Erosion and sediment control devices tend to collect litter. Remove this solid waste promptly
- Make sure that toxic liquid wastes (used oils, solvents, and paints) and chemicals (acids, pesticides, additives, curing compounds) are not disposed of in dumpsters designated for construction debris
- Salvage or recycle any useful material. For example, trees and shrubs from land clearing can be used as a brush barrier, or converted into wood chips, then used as mulch on graded areas.

- Do not hose out dumpsters on the construction site. Leave dumpster cleaning to trash hauling contractor.
- Arrange for regular waste collection before containers overflow
- If a container does spill, clean up immediately.
- Make sure that construction waste is collected, removed, and disposed of only at authorized disposal areas.
- Train employees and subcontractors in proper solid waste management
- For a quick reference on disposal alternatives for specific wastes, see Table 5-1.

5.2.8 **BMP 37: Hazardous Waste Management**

Description

Prevent or reduce the discharge of pollutants to stormwater from hazardous waste through proper material use, waste disposal, and training of employees and subcontractors.

Approach

Many of the chemicals used on-site can be hazardous materials that become hazardous waste upon disposal. These wastes may include:

- Paints and solvents
- Petroleum products such as oils, fuels, and grease
- Herbicides and pesticides
- Acids for cleaning masonry
- Concrete curing compounds

In addition, sites with existing structures may contain wastes that must be disposed of in accordance with Federal, State, and local regulations. These wastes include:

- Sandblasting grit mixed with lead-, cadmium-, or chromium-based paints
- Asbestos
- PCBs (particularly in older transformers)

The following steps will help reduce stormwater pollution from hazardous wastes:

Material Use

- Use the entire product before disposing of the container
- Do not remove the original product label, it contains important safety and disposal information
- Do not over-apply herbicides and pesticides. Prepare only the amount needed. Follow the recommended usage instruction. Over-application is expensive and environmentally harmful. Apply surface dressings in several smaller applications, as opposed to one large application, to allow time for infiltration and to avoid excess material being carried off-site by runoff. Do not apply these chemicals just before it rains. People applying pesticides must be certified in accordance with Federal and State regulations.
- Do not clean brushes or rinse paint containers into the dirt, street, gutter, storm drain, or stream. “Paint out” brushes as much as possible. Rinse water-based paints to the sanitary sewer. Filter and re-use thinners and solvents. Dispose of excess oil-based paint and sludge as hazardous waste.

Waste Recycling/Disposal

- Select designated hazardous waste collection areas on-site

- Hazardous materials and wastes must be stored in covered containers and protected from vandalism.
- Place hazardous waste containers in secondary containment
- Do not mix wastes. This can cause chemical reactions, make recycling impossible, and complicate disposal.
- Recycle material such as used oil or water-based paint
- Make sure toxic liquid wastes (used oils, solvents, and paints) and chemicals (acids, pesticides, additives, curing compounds, etc.) are not disposed of in dumpsters designated for construction debris.
- Arrange for regular waste collection before containers overflow
- Make sure that hazardous waste (e.g., excess oil-based paint and sludge) is collected, removed, and disposed of only at an authorized disposal area.
- For a quick reference on disposal alternatives for specific wastes, see Table 5-1.

Training

- Train employees and subcontractors in proper hazardous waste management
- Warning signs should be placed in areas recently treated with chemical
- Place a stockpile of spill cleanup materials where it will be readily accessible
- If a container does spill, clean up immediately

5.2.9 **BMP 38: Contaminated Soil Management**

Description

Prevent or reduce the discharge of pollutants to stormwater from contaminated soil and highly acidic or alkaline soils by conducting pre-construction surveys, inspecting excavations regularly, and remediating contaminated soil promptly.

Approach

Contaminated soils may occur on your site for several reasons including:

- Past site uses and activities
- Detected or undetected spills and leaks
- Acid alkaline solutions from exposed soil or rock formations high in acid or alkaline forming elements.

Most developers conduct pre-construction environmental assessments as a matter of routine. Recent court rulings holding contractors liable for cleanup costs when they unknowingly move contaminated soil highlight the need for contractors to confirm a site assessment is complete before earth moving begins.

The following steps will help reduce stormwater pollution for contaminated soil:

- Conduct thorough site planning including pre-construction geologic surveys
- Look for contaminated soil as evidenced by discoloration, odors, differences in soil properties, abandoned underground tanks or pipes, or buried debris
- Prevent leaks and spills to the maximum practical extent. Contaminated soil can be expensive to treat and/or dispose of properly. However, addressing the problem before construction is much less expensive than after the structures are in place.
- Test suspected soils at a certified laboratory

- If the soil is contaminated, work with the local regulatory agencies to develop options for treatment and/or disposal.
- For a quick reference on disposal alternatives for specific wastes, see Table 5-1.

5.2.10 **BMP 39: Concrete Waste Management**

Description

Prevent or reduce the discharge of pollutants to stormwater from concrete waste by conducting washout off-site, performing on-site washout in a designated area, and training employees and subcontractors.

Approach

The following steps will help reduce stormwater pollution from concrete wastes:

- Store dry and wet materials under cover, away from drainage areas
- Avoid mixing excess amounts of fresh concrete or cement on-site
- Perform washout of concrete trucks off-site or in designated areas only
- Do not wash out concrete trucks into storm drains, open ditches, streets, streams or onto exposed soils.
- Do not allow excess concrete to be dumped on-site, except in designated areas
- For on-site washout

Locate washout area at least 50 feet from storm drains, open ditches, or water bodies. Do not allow runoff from this area by constructing a temporary pit or bermed area large enough for liquid and solid waste.

Wash out wastes shall be placed into a secondary containment container or a lined facility, where the concrete can be set, be broken up, and then disposed of properly.

- When washing concrete to remove fine particles and expose the aggregate, avoid creating runoff by draining the water to a bermed or level area.
- Do not wash sweepings from exposed aggregate concrete into the street or storm drain. Collect and return sweepings to aggregate base stockpile or dispose in the trash.
- Train employees and subcontractors in proper concrete waste management
- For a quick reference on disposal alternatives for specific wastes, see Table 5-1.

5.2.11 **BMP 40: Vehicle and Equipment Cleaning**

Description

Prevent or reduce the discharge of pollutants to stormwater from vehicles and equipment by using off-site facilities; washing in designated, contained areas only; eliminating discharges to the storm drain by infiltrating or recycling the wash water; and/or training employees and subcontractors.

Approach

- Use off-site commercial washing business as much as possible. Washing vehicles and equipment outdoors or in areas where wash water flows onto paved surfaces or into drainage pathways can pollute stormwater. If you wash a large number of vehicles or pieces of equipment, consider conducting this work at an off-site commercial business. These businesses are better equipped to handle and dispose of the wash waters properly. Performing this work off-site can also be economical by eliminating the need for a separate washing operation at your site.

- If washing must occur on-site, use designated bermed wash areas to prevent wash water contact with stormwater, creeks, rivers, and other water bodies. The wash area can be sloped for wash water collection and subsequent infiltration into the ground.
- Use as little water as possible to avoid having to install erosion and sediment control for the wash area.
- Use phosphate-free, biodegradable soaps.
- Educate employees and subcontractors on pollution prevention measures.
- Do not permit steam cleaning on-site. Steam cleaning can generate significant pollutant concentrations.
- For a quick reference on disposal alternatives for specific wastes, see Table 5-1.

5.2.12 **BMP 41: Vehicle and Equipment Fueling**

Description

Prevent fuel spills and leaks and reduce their impacts to stormwater by using off-site facilities, fueling in designated areas only, enclosing or covering stored fuel, implementing spill controls, and training employees and subcontractors.

Approach

- Use off-site fueling stations as much as possible. Fueling vehicles and equipment outdoors or in areas where fuel may spill/leak onto paved surfaces or into drainage pathways can pollute stormwater. If you fuel a large number of vehicles or pieces of equipment, consider using an off-site fueling station. These businesses are better equipped to handle fuel and spills properly. Performing this work off-site can also be economical by eliminating the need for a separate fueling area at your site.
- If fueling must occur on-site, use designated areas, located away from drainage.
- Discourage “topping-off” of fuel tanks
- Always use secondary containment, such as a drain pan or drop cloth, when fueling to catch spills/leaks.
- Place a stockpile of spill cleanup materials where it will be readily accessible.
- Use adsorbent material on small spills rather than hosing down or burying the spill. Remove the adsorbent materials promptly and dispose of properly.
- Carry out all Federal and State requirements regarding stationary above-ground storage tanks.
- Avoid mobile fueling of mobile construction equipment around the site; rather, transport the equipment to designated fueling areas. With the exception of tracked equipment such as bulldozers and perhaps forklifts, most vehicles should be able to travel to a designated area with little lost time.
- Train employees and subcontractors in proper fueling and cleanup procedures.
- For a quick reference on disposal alternatives for specific wastes, see Table 5-1.

5.2.13 **BMP 42: Vehicle and Equipment Maintenance**

Description

Prevent or reduce the discharge of pollutants to stormwater from vehicle and equipment maintenance by running a “dry site.” This involves using off-site facilities, performing work in designated areas only, providing cover for materials stored outside, checking for leaks and spills, containing and cleaning up spills immediately, and training employees and subcontractors.

Approach

- Keep vehicles and equipment clean; do not allow excessive build-up of oil and grease.
- Use off-site repair shops as much as possible. Maintaining vehicles and equipment outdoors or in areas where vehicles or equipment fluids may spill or leak into the ground can pollute stormwater. If you maintain a large number of vehicles or pieces of equipment, consider using an off-site repair shop. These businesses are better equipped to handle vehicle fluids and spills properly. Performing this work off-site can also be economical by eliminating the need for a separate maintenance area.
- If maintenance must occur on-site, use designated areas, located away from drainage courses, to prevent the run-on of stormwater and the runoff of spills.
- Always use secondary containment, such as a drain pan or drop cloth, to catch sills or leaks when removing or changing fluids.
- Place a stockpile of spill cleanup materials where it will be readily accessible.
- Use adsorbent materials on small spills rather than hosing down or burying the spill. Remove the adsorbent materials promptly and dispose of properly.
- Regularly inspect on-site vehicles and equipment for leaks, and repair immediately.
- Check incoming vehicles and equipment (including delivery trucks and employee and subcontractor vehicles) for leaking oil and fluids. Do not allow leaking vehicles or equipment on-site.
- Segregate and recycle wastes, such as greases, used oil or oil filters, antifreeze, cleaning solutions, automotive batteries, hydraulic, and transmissions fluids.
- Train employees and subcontractors in proper maintenance and spill cleanup procedures.
- For a quick reference on disposal alternatives for specific wastes, see Table 5-1.

5.2.14 **BMP 43: Employee and Subcontractor Training**

Description

Employee/subcontractor training, like maintenance on a piece of equipment, is not so much a best management practice as it is a method by which to implement BMPs. This fact sheet highlights the importance of training and of integrating the elements of employee/subcontractor training from the individual source controls into a comprehensive training program as part of the EPSC plan.

The specific employee/subcontractor training aspects of each of the source controls are highlighted in the individual fact sheets. The focus of this fact sheet is more general and includes the overall objectives and approach for assuring employee/subcontractor training in stormwater pollution prevention. Accordingly, the organization of this fact sheet differs from the other fact sheets in the chapter.

Objectives

Employee/subcontractor training should be based on four objectives:

- Promote a clear identification and understanding of the problem, including activities with the potential to pollute stormwater
- Identify solutions (BMPs)
- Promote employee/subcontractor ownership of the problems and the solutions
- Integrate employee/subcontractor feedback into training and BMP implementation

Approach

- Integrate training regarding stormwater quality management with existing training programs that may be required by other regulations, the Hazardous Waste Operations and Emergency Response

standard (29CFR 1910.120), or the Spill Prevention Control and Countermeasure Plan (40CFR 112).

- Train employees/subcontractors in standard operating procedures and spill cleanup techniques described in the Pollution Control Plan. Employee/subcontractors trained in spill containment and cleanup must be present during the loading/unloading and handling of materials.
- Personnel who use pesticides must be trained in their use.
- Educating off-site contractors and subcontractors supports the efforts of well-trained employees.
- Consider posting the quick reference table around the job site or in the on-site office trailer to reinforce training.
- Train employees/subcontractors in standard operating procedures and spill cleanup techniques described in the fact sheets. Employees/subcontractors trained in spill containment and cleanup must be present during the loading/unloading and handling of materials.
- Personnel who use pesticides must be trained in their use. The Oregon Department of Pesticide Regulation and county agricultural commissioner's license pesticide dealers, certify pesticide applicators, and conduct on-site inspections.
- Proper education of off-site contractors is often overlooked. The conscientious efforts of well-trained employees/subcontractors can be lost by unknowing off-site contractors, so make sure they are well informed about what they are expected to do on-site.

5.2.15 BMP 44: Portable Toilet

Description

Prevent or reduce the discharge of pollutants to stormwater from onsite portable toilets used during construction. Such pollutants include bacteria, organic matter, disinfectants, and suspended soils.

Objectives

Approach

- Place toilets on flat stable ground. Toilets shall be located outside of vehicular and work areas. Toilets shall not be located in the public right-of-way.
- Locate toilets as far from storm drains as possible. Provide secondary containment to prevent risk of leak or spill. The toilets must be at least 20 feet away from any storm drain or streets and 75 feet away from any sensitive areas.
- Avoid placement on impervious surfaces such as concrete, that will quickly direct spills to the MS4 system. Grass, sand and gravel surfaces will adsorb liquid for easy cleanup of leaks or spills.
- Place toilets inside security fences to prevent vandalism.
- Consider securing toilets to the ground with cables and stakes if they are located in an open area subject to high winds.
- Ensure easy access for pump truck and toilet service staff.

Maintenance

- Follow vendor recommendations for a suitable number of toilets for the anticipated site workforce.
- Provide a suitable cleaning and maintenance schedule.
- Check weekly for damage, leaks, and spills.
- Clearly label toilets needing maintenance or repair. Promptly notify vendor to schedule maintenance.
- Rinse water generated during cleaning of portable toilet must not be discharged to the ground or MS4 system and must be retaining within the tank.

- Maintain spill response material and equipment on site.

REFERENCES

Blueprint for a Clean Bay-Construction-Related Industries: Best Management Practices for Stormwater Pollution Prevention; Santa Clara Valley Nonpoint Source Pollution Control Program, 1992

Erosion Prevention and Sediment Control Manual, City of Corvallis, September 2005

Stormwater management for Construction Activities, Developing Pollution Prevention Plans and Best Management Practices, EPA 832-R-92005; USEPA, April 1992.

Hot-mix Asphalt Paving Handbook, U.S. Army Corps of Engineers, Ac 150/5370-14, Appendix July 1991

Best Management Practices and Erosion Control Manual for Construction Sites; Flood Control District of Maricopa County, AZ. September 1992

Coastal Nonpoint Pollution Control Program: Program Development and Approval Guidance, Working Group Working Paper; USEPA, April 1992

Processes, Procedures, and Methods to Control Pollution Resulting from all Construction Activity; USEPA, 430/0-73-007, 1973.

Swisher, R.D., 1987. Surfactants Biodegradation, Marcel Decker Corporation

Erosion Prevention and Sediment Control Manual. City of Corvallis, OR, 2008

CHAPTER 6: MAINTENANCE AND INSPECTION

Erosion prevention and sediment control (EPSC) measures are required to be installed on all construction sites prior to any land disturbing activities being performed. Such activities have the potential to impact natural systems deemed worthy of protection. An EPSC plan is required to be submitted for all construction sites within the Albany city limits where land disturbing activity is performed that meets the requirements identified in Chapter 2. Inspection and Maintenance of EPSC measures throughout the life of the project are imperative to ensure their effective performance. Unless the measures are properly installed and maintained, there is a strong chance of failure during the construction period.

6.1 Erosion and Pollution Control Manager

Larger, more complex construction sites such as subdivisions and commercial and street projects require ongoing, detailed inspection and maintenance for longer periods of time. These projects may also be subject to the Site Improvement permitting requirements identified in Title 15 of the Albany Municipal Code. Although the EPSC measures and processes required under Title 12 are equally applicable to these projects, permitting may be incorporated within the Site Improvement (SI) permitting process.

The owner of the site shall designate a competent person, known as the Erosion and Pollution Control Manager (EPCM), possessing knowledge and experience that, to the City's satisfaction, qualify him or her in erosion and sediment control techniques. At a minimum the EPCM shall have a thorough knowledge of the content of this manual. It is also recommended the EPCM should have attended a class on erosion and sediment control materials and installation practices which are outlined in this manual. For sites over 1 acre of disturbance, the EPCM is required to be a certified CESCL. The EPCM shall be responsible for ensuring the implementation of the EPSC plan and have the authority to immediately mobilize necessary personnel and equipment to correct and modify erosion prevention and sediment controls when required.

Duties of the EPCM include:

- Manage and ensure proper implementation of the EPSC plan
- During periods of active construction, maintain the EPSC plan at the project site, available for review upon request
- Accompany the City in a field review of the EPSC plan prior to the beginning of work
- Inspect erosion and sediment controls on active construction sites weekly
- Inspect erosion and sediment controls on inactive sites at least biweekly
- Inspect erosion and sediment controls on both active and inactive sites at least daily during rainy periods where a minimum 0.5 inch of rain has fallen in a 24-hour period
- Mobilize crews to make immediate repairs to the controls or install controls during working and non-working hours
- Record measures taken to clean up significant amounts of sediment
- Complete erosion control monitoring forms after each inspection
- Maintain up to date EPSC plan throughout the life of the project
- Prepare a contingency plan in preparation for emergencies and the rainy season
- Accompany the City on inspections

6.1.1 Ineffective Controls

The EPCM shall record measures to clean up significant amounts of sediment. Should a control measure not function effectively, one or more of the following tasks must be performed.

- Immediately repair the control.

- Replace the control.
- Provide additional controls.

6.2 Pre-Construction Meeting

The EPCM, contractor and inspector shall carefully review the EPSC plan prior to the pre-construction meeting to understand what is required. Implementing the EPSC plan and assuring its performance may involve significant expense. The following pre-construction activities should be required:

- Prior to the pre-construction meeting, review and comment of the EPSC plan
- During the pre-construction meeting, review all comments and concerns
- Prohibit clearing and grading operations prior to EPSC plan approval and implementation
- Tentatively locate construction accesses
- Delineate clearing limits, drainage courses, easements, setbacks, wetlands, and other sensitive areas and their buffers

The pre-construction meeting provides an opportunity for the contractor to discuss the plan with the inspector and learn which elements of the EPSC plan deserve the most attention. Adjustments to improve performance or make installation easier and maintenance more reliable may also be discussed.

The pre-construction meeting is also an opportunity to discuss the inspection schedule and procedures. Key points to consider in the pre-construction meeting are:

- Pollution Control Plan for contractor operations
- Qualifications of individuals designated as competent person for EPSC plan
- Method to be used to document the up-to-date EPSC plan
- Adjacent areas that need special protection from sedimentation, particularly environmentally sensitive areas such as wetlands, stream crossings, channel, and water disposal outlets
- Location of erosion and sediment control BMPs and their implementation
- Sequence of installation with respect to the construction schedule
- Surface stabilization plans, temporary and permanent seeding
- Construction schedule and any anticipated shutdown periods
- Maintenance plans and the contractor's procedure for monitoring performance
- Location of all borrow and disposal areas
- Emergency or contingency plans
- Any special requirements identified in permits
- Monitoring form used and availability
- Biological Assessment – this report comes from the consultant and covers special needs and concerns for threatened and endangered species on the project. The contractor should be aware of its contents.

6.2.1 Modified EPSC Plan

All projects will include an EPSC plan. This plan is a guide and ideally should have addressed all erosion problems for the project adequately. However, the EPSC plan should not be followed blindly. It is the owner's or EPCM's responsibility to propose modifications to the plan.

In addition, effective erosion control is closely tied to a contractor's staging, operation methods, and construction timing. When the EPSC plan is developed, the contractor's staging and operation methods are unknown. Therefore, it is expected changes to the EPSC plan will be updated throughout the life of the project. As modifications to the EPSC plan take place, it is extremely important to secure the interest of all parties. Communication between the contractor, designated person, and the inspector is vital.

Depending upon the level of modification, the design engineer may need to be consulted and changes

to the EPSC plan must be submitted to the City. Regardless of the magnitude, a contingency plan must be implemented immediately. Minor modifications to the EPSC plan such as installing small sections of sediment control barriers, can be field adjusted and handwritten on the plans.

6.2.2 Construction Schedule Review

The implementation of the construction schedule must include the following:

- Timing of activities to limit seasonal and weather impacts
- Timing of wet season work and any temporary work shut down
- Time of activities to meet “in-water” work restrictions
- Erosion prevention and sediment controls shown on the plans should be installed before ground-disturbing activities begin
- Permanent facilities, such as sediment traps and basins, which will be used during construction as temporary measures should be installed
- Retention of temporary perimeter controls until all upstream areas are finally stabilized
- Timing of seeding operations

6.2.3 Monitoring Form

On all development sites, inspections are to be recorded on the Erosion Control Monitoring Form (See Appendix). The effectiveness of each BMP at every location on site shall be documented on the form and general observations on site conditions should also be recorded. Information provided on the form is useful for tracking repairs and demonstrating permit compliance. It is noteworthy that in the event of permit violations or subsequent enforcement actions, the information recorded on the form, along with photographs and videos, may be used to evaluate the responsibility of involved parties.

6.3 Materials

The purpose of this manual is to provide cost effective, environmentally sensitive management of erosion. This manual illustrates materials that have been approved based on geographical controls such as climate and soil type. Materials not listed in this manual may be approved based on equal to or greater than criteria. Specific questions regarding approval of alternative materials and procedures can be answered by calling the City of Albany Public Works Department, (541) 917-7676.

6.4 Installation

It must be understood that installation is equally important to the value and success of the materials. If installed incorrectly, even the best materials will fail causing more damage and additional expense to the project. For this reason alone, installation procedures must be followed very closely.

Installation of all base measures must be inspected, and any deficiencies corrected prior to the start of land disturbing activities. Subsequent inspections of any additional installations should also be made throughout the life of the project as needed.

The inspector, contractor, and EPCM shall be familiar with installations details for each BMP used on the project. Details for the installation of all specified BMPs should be provided in the EPSC plan. Installation details for BMPs are also provided in Chapter 4 of this manual.

6.5 Inspection Requirements

The owner or designated person (EPCM) shall be required to provide ongoing inspection of erosion and sediment BMP control measures throughout the life of the project. Inspections shall be recorded on an approved monitoring form.

Minimum inspection requirements shall be as follows.

- Once per week on active sites
- Once every two weeks on in-active sites
- Within 24 hours following a 0.5-inch rain event

6.5.1 Inspection of Work Restriction Areas

All construction projects are required to restrict certain types of work, which may contribute to sediment-laden water leaving the project boundaries or entering waterways. The following work restrictions need to be inspected prior to the start of work and throughout the life of the project.

- Flag Clearing Limits: Construction site clearing limits will be clearly flagged in accordance with the approved plans. No ground disturbance is permitted beyond the flagged boundary. Flagging must be maintained for the duration of construction.
- Perimeter Controls before Grubbing: All appropriate perimeter controls must be installed prior to any major site grubbing operation. Perimeter controls include interceptor ditches, berms, infill areas, and sediment fences along the banks of existing streams and toes of slopes.
- Wet Weather Season Plan and Schedule: Prior to the wet season construction work and before temporary work suspension for winter, the contractor or designated person shall meet with the city to review and update the EPSC plan and to develop a schedule to ensure appropriate controls are implemented and maintained during the wet season work and suspended periods.
- Limit Disturbed Areas: If soil erosion and sediment resulting from construction activities is not effectively controlled, the city will limit the amount of disturbed areas that can be effectively controlled.
- Install BMPs Early: Erosion and sediment control BMPs should be incorporated into the projects as early as practical. All erosion and sediment BMP control measures must be installed according to the approved implementation schedule and with these specifications.
- Remedies of the City: Failure to control erosion and or pollution shall be cause for the City to pursue all remedies authorized by Title 12 of the Albany Municipal Code. These include stopping all construction work, undertaking separate abatement activities at the permit holder’s expense, and assessing fines each day until measures have been taken to bring all construction into compliance with these specifications.

6.6 Stabilization Requirements

All soil exposed and disturbed by construction-related activities should be stabilized with temporary or permanent BMPsas soon as possible. Disturbed areas where work is not commencing must be stabilized within 7 days.

6.7 Erosion Control Contingency Items

It is a requirement that all construction sites have materials on hand as a contingency in the event of a failure or when required to shore up BMPs installed as part of the EPSC plan. The contingency items may also be used at the discretion of the project inspector to strengthen the erosion control measures as needed during construction. At a minimum, the following materials are to be kept on the project site for use in emergencies.

For minor land disturbing activities as described in Chapter 2

24 feet of sediment fence
250 square feet or plastic sheeting
100 feet of rope

For major land disturbing activities as described in Chapter 2

100 feet of sediment fence
500 square feet or plastic sheeting
1,000 feet of rope

10 empty sandbags (to be filled as needed)	50 empty sandbags (to be filled as needed)
2 bales of straw (used for ground cover)	10 bales of straw (used for ground cover)
4 bio-filter bags with stakes	10 bio-filter bags with stakes

6.8 **Maintenance**

Erosion and sediment control BMPs must be maintained in good working order at all times in order to function as intended. These controls must be maintained in place until the City issues notification of acceptance of permanent stabilization.

Typical maintenance activities, guidelines, and failure modes for BMPs are discussed in Chapter 4 of this manual. The inspector should be familiar with maintenance requirements for each BMP used on the project. It is noteworthy that maintenance activities and frequencies vary among the different BMPs and will depend largely on weather and other site conditions. In general, the more effective erosion prevention measures are, the less maintenance will be required for sediment control BMPs.

6.8.1 **Sediment Removal**

Sediment shall be removed, and the controls upgraded or repaired as outlined in Chapter 4 BMP maintenance, or as directed. In the event of continuous rainfall over a 24-hour period, or other circumstances that preclude equipment operation in that area, additional sediment control shall be hand-carried and installed in accordance with best management practices and as approved by the City. Sediment shall be removed from controls such as sediment fences, sediment barriers, check dams, inlet protection, and sediment traps when the sediment buildup has reached $\frac{1}{3}$ the exposed height of the control or storage depth. Rock filters and filter berm material shall be replaced with new rock material when sediment reduces the filtering capacity by 50 percent. Rock or other material specified shall be added or removed as needed to maintain proper function of the entrance areas. All paved areas shall be kept clean (by mechanical means) for the duration of the project.

6.8.2 **Sediment Disposal**

Removed sediment shall be placed in a non-erodible area within the construction site or removed and disposed of offsite in accordance with all federal, state, and local laws and ordinances. Sediment-laden water shall not be flushed into the stormwater system.

6.9 **Inspector Checklist**

The Inspector Checklist included in Appendix B will be used by City representatives when inspecting erosion and sediment control BMPs on a project site. The checklist is intended to summarize the key elements of a successful erosion and sediment control program. Topics on the checklist include:

- Schedule Review
- Erosion and Sediment Control Plan
- Erosion and Pollution Control Manager
- Sensitive Areas
- Contingency Plans
- Materials On-Hand
- Maintenance
- Monitoring Forms
- Slope Protection and Stabilization
- Plan Revisions and Modifications

- BMP Evaluation
- Additional Items

6.9.1 Winterization

The wet weather season is October 1st through April 30th. Prior to wet weather season work and before temporary work suspension for winter, the contractor shall meet with the City to review and update the EPSC plan and to develop a schedule to assure that appropriate controls are implemented and maintained during wet season and work suspension periods. Winter preparations should begin in August.

6.9.2 Designer/Inspector Toolbox

Several worksheets are provided in Appendix B to aid designers and inspectors in determining and verifying the quality and quantity of various erosion control items. These are especially useful when verifying the application rates of various mulch and hydraulically applied products. Appendix B includes the following:

- Rainfall Intensity and Duration Frequency Curves
- Slope Inclination Conversions
- Wood Fiber Mulch Hydraulic Application Worksheet
- Seed/Fertilizer Hydraulic Application Worksheet
- Hydraulic Application Example Problems
- Seed or Fertilizer Hydraulic Application
- Wood Fiver Mulch Hydraulic Application

Appendix A

Sample EPSC Plans and Submittal Requirements

Minor Land Disturbing Activity Submittal Requirements

Minor Land Disturbing Activity Sample Plan

Major Land Disturbing Activity Submittal Requirements

Major Land Disturbing Activity Sample Plan

Minor Land Disturbing Activity - Plan Submittal Requirements

EROSION PREVENTION AND SEDIMENT CONTROL (EPSC)

An EPSC permit is required for all land-disturbing activities affecting an area of two thousand square feet or greater, cumulatively.

Minor Land Disturbing Activity

- Individual single-family home or duplex construction on existing lots of record, or manufactured home placement on individual lots or in manufactured home parks.
- The affected area is less than one acre in size.
- Average slopes throughout the disturbed area do not exceed 10 percent.
- Slopes greater than 3:1 do not exceed six feet in height.
- Concentrated runoff through the disturbed area does not originate from more than one acre off site.
- The site does not contain sensitive areas.

You must submit a completed EPSC permit application along with your EPSC site plan. The Sample Residential Site Plan (Attached) may be used if site has no sensitive areas, steep slopes, and is under one acre. Follow the checklist below to create the EPSC site plan.

Start with a copy of your site plan, drawn to scale, showing the following:

- Property lines, easements (with widths), and north arrow. Show the lengths along property lines. Show the distances to buildings and structures.
- Elevations on the property to indicate the amount of fall and/or grades across the property.
- Contour lines showing the existing and final grades/topography of the site.
- Flow arrows showing existing (light) and proposed (dark) drainage patterns. It is the permit holders responsibility not to alter the flow of surface water to harm neighboring properties.
- Proximity to sensitive areas.
- Location of the 100-year flood plain, if applicable.
- Location and size of drainage ways, swales, ditches, etc.
- Location of utilities on the property (sewer, water, etc.)
- All areas of disturbance on the site, including areas that will be cleared, graded, or excavated.
- Location for storage of soils and/or wastes.

Show the location of Erosion Prevention and Sediment Control Measures:

- Place EPSC measures in accordance with the Best Management Practices (BMPs) shown in the City of Albany EPSC Manual. Examples include:
 - Gravel Construction Entrance;
 - Perimeter Control;
 - Inlet protection;
 - Undisturbed buffer zones (*10-foot minimum width for slopes < 5%, fence off with orange construction fencing*).
- Clearly designate a concrete wash-out area for all concrete trucks, mortar, and concrete tools.

Provide a construction schedule showing:

- Installation date for EPSC BMPs;
- Commencement date for land disturbing activities;
- Construction completion date;
- Site stabilization date.



Minor Land Disturbing Activity - Plan Submittal Requirements

EROSION PREVENTION AND SEDIMENT CONTROL (EPSC)

Standard permit conditions

1. Prior to any ground disturbing activity on the site, an initial inspection by City staff is required. EPSC Best Management Practices (BMPs) must be in place prior to the inspector arriving. Call (541) 791-0116 to schedule your inspection.
2. EPSC BMPs must be installed in such a manner as to ensure that sediment and sediment-laden water does not enter upon adjacent properties or rights-of-way, the stormwater system, wetlands, or Waters of the State.
3. EPSC BMPs shown on the plans are minimum requirements for anticipated site conditions. During the construction period, the EPSC measures shall be upgraded as needed for unexpected storm events and to ensure that sediment and sediment-laden water does not leave the site.
4. EPSC BMPs shall be inspected daily by the permit holder and maintained as necessary to ensure their function.
5. Stabilized gravel construction entrances shall be installed at the beginning of construction and maintained for the duration of the project. Additional measures may be required to ensure that all paved areas are kept clean for the duration of the project.
6. EPSC BMPs shall be kept in place until permanent ground cover is established.
7. Exposed soil must be permanently stabilized against wind and water erosion before the EPSC permit can be closed. Once the site is stabilized, schedule a final inspection by calling (541) 791-0116. Permanent soil stabilization includes landscaping, seeding, or covering exposed soil with a minimum 2-inch layer of bark or wood chips, per Section 2.3.3 of the EPSC Manual.
8. It is the property owner's responsibility to ensure that any proposed grading, fill, excavation, or other site work does not negatively impact drainage patterns to or from adjacent properties.

Wet Weather Season

- Wet weather BMPs will be in effect from October 1st through April 30th. However, the project site is required to manage runoff from the site year around.
- Rain is the driving factor behind most erosion in this region. Rainfall impact and surface water runoff over exposed soil dislodges sediment particles, suspending them in moving water. Saturated soils are more easily tracked off site by equipment.
- During the wet weather season or when rain is forecasted additional Erosion Prevention and Sediment Control BMPs are required. The project shall have these BMPs onsite and readily available year-round.

Where can I get assistance?

- We are here to help you. Staff are typically available from 8:00 am to 5:00 pm weekdays to answer your questions by phone at (541) 917-7676, and at the Public Works Department front counter in City Hall, 333 Broadalbin Street SW. We encourage you to call and make arrangements for a free on-site consultation.
- The City's GIS mapping service is available at: <https://infohub.cityofalbany.net/infohub/>
- Floodplain data can be obtained from FEMA at: <https://msc.fema.gov/portal/home>
- The City's EPSC Manual and related information found on the EPSC website: <https://albanyoregon.gov/pw/engineering/erosion-prevention-and-sediment-control>
- Sample Site Plan, attached.



City of Albany Public Works Department – Erosion Prevention & Sediment control
333 Broadalbin Street SW
(541) 917-7646

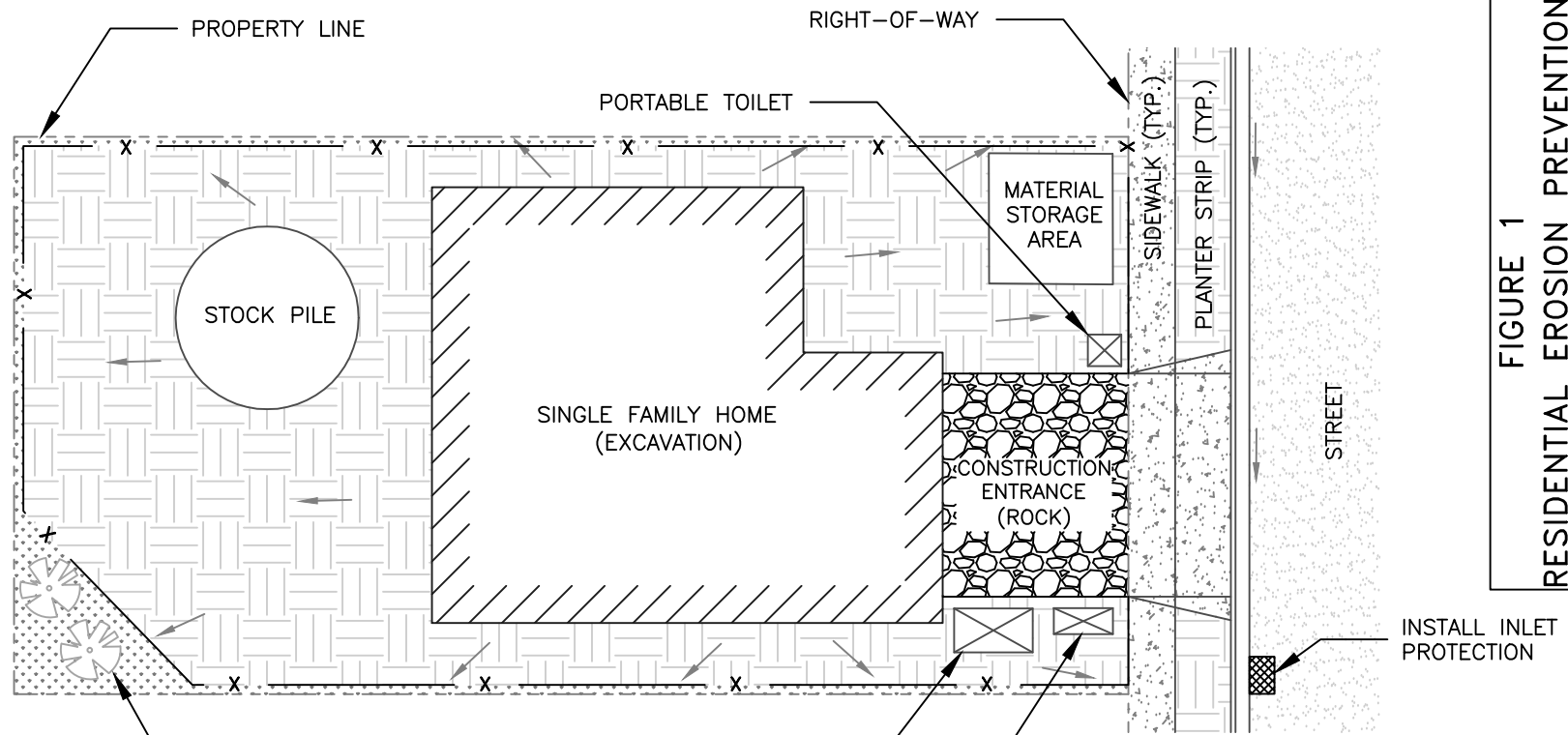

**FIGURE 1
RESIDENTIAL EROSION PREVENTION
AND SEDIMENT CONTROL PLAN***

1" = 20' OCTOBER 2017

SENSITIVE AREA TO BE MARKED OFF AND PROTECTED

DUMPSTER
CONCRETE WASHOUT

INSTALL INLET PROTECTION

LEGEND

- PROPERTY LINE
- x — PERIMETER CONTROL
- DRAINAGE ARROWS
- [Disturbed Area Pattern] DISTURBED AREA TO BE STABILIZED
- [Existing Vegetation Pattern] EXISTING VEGETATION
- [Tree Symbol] EXISTING TREES

REQUIRED BASE MEASURES

- PERIMETER CONTROL
- CONSTRUCTION ENTRANCE
- STORM DRAIN INLET PROTECTION

CONSTRUCTION SITE BMP MEASURES

- STORE ALL PAINT, SOLVENTS AND HAZARDOUS MATERIALS IN AN ENCLOSED AREA.
- SWEEP STREET AND HARD SURFACES TO DISPOSE OF ANY TRACK OFF MATERIAL.
- PERFORM FUELING AND VEHICLE MAINTENANCE AT AN OFF-SITE FACILITY.
- CLEAN UP SPILLS PROMPTLY USING ONSITE SPILL KIT.

NOTES

- DIG OUT FOR CONSTRUCTION ENTRANCE AND BUILDING PAD CAN OCCUR ONCE SEDIMENT CONTROLS ARE IN PLACE.
- ADDITIONAL SEDIMENT CONTROLS MEASURES MAY BE REQUIRED AS SITE CONDITIONS CHANGE TO PREVENT SEDIMENT FROM LEAVING THE SITE AND/OR ENTERING STORM SYSTEM.
- ALL DISTURBED AREAS MUST BE STABILIZED BEFORE THE EPSC PERMIT CAN BE FINALIZED.
- CALL FOR AN INSPECTION OF EPSC INSTALLATIONS.
- IF YOU HAVE ANY QUESTIONS, CONCERNS OR NEED TO REQUEST AN INSPECTION PLEASE CALL 541-791-0116.
- WET WEATHER CONDITIONS APPLY OCTOBER 1ST THROUGH APRIL 30TH.

* THIS PLAN APPLIES TO RESIDENTIAL SITE OF LESS THAN 5% SLOPE AND NOT ADJACENT TO SENSITIVE AREAS SUCH AS STREAM, WETLANDS AND RIPARIAN AREAS.

Major Land Disturbing Activity - Plan Submittal Requirements

EROSION PREVENTION AND SEDIMENT CONTROL (EPSC)

An EPSC permit is required for all land-disturbing activities affecting an area of two thousand square feet or greater, cumulatively.

Major Land Disturbing Activity

Major land disturbing activities are those that meet the requirements for an EPSC permit noted above, and the affected area meets one or more of the following conditions:

- Affect an area over an acre in size; or
- Average slopes throughout the disturbed area exceed 10%; or
- Slopes greater than 3:1 exceed six feet in height; or
- Concentrated runoff through the disturbed area originates from more than one acre off-site; or
- The site contains sensitive areas.

You must submit a completed EPSC permit application along with your EPSC site plan. A Sample Site Plan for Major Land Disturbing Activity (Attached) is provided for reference. Follow the checklist below to create the EPSC site plan.

Submit a completed Erosion Prevention and Sediment Control (EPSC) application form. Submit one set of the EPSC plan, drawn to scale, showing the following:

- Vicinity map, property address, and property owner's name and address.
- Locations, types, and applicable dimensions of EPSC Best Management Practices (BMPs).
- Applicable details of erosion control BMPs showing full dimensions of construction info.
- Existing and proposed ground contours, including a minimum of the first 50 feet of abutting property.
- Arrows to indicate existing and final flow patterns of surface water. It is the permit holder's responsibility not to alter the flow of surface water to harm neighboring properties.
- Locations and sizes of existing and proposed channels and drainage pipes (labeled as such and with arrows indicating flow direction) on and immediately upstream and downstream of the site.
- Location of the 100-year flood plain, if applicable.
- Site entrances/exits (as approved by the City).
- Applicable standard erosion control notes from Appendix, with additions or changes as required.
- Other notes including references to timing of placement and removal of erosion control measures, and erosion measure specifications such that types and quantities of materials necessary for the installation of the erosion control measures are fully detailed.
- Stamp or signature of the person preparing the plan, licensed as a professional civil or environmental engineer, landscape architect, geologist, or certified professional in erosion and sediment control.**

Submit a construction schedule showing the following:

- Construction start and completion dates.
- Dates when erosion control measures will be in place.
- Timing of site clearing and grading, placement of fills and excavations.
- Projected date of removal of erosion control measures (after landscaping is established or after establishment of a healthy grass stand or other approved vegetation).

Submit a copy of any applicable 1200-C permit issued by ODEQ. If application has been made to ODEQ but a permit has not yet been issued, provide a copy of the completed application filed with ODEQ. Provide a copy of the NPDES 1200-C permit when it is issued. A RUSLE 2 report may be required for any project adjacent to

City of Albany Public Works Department – Erosion Prevention & Sediment control

333 Broadalbin Street SW

(541) 917-7646



Major Land Disturbing Activity - Plan Submittal Requirements

EROSION PREVENTION AND SEDIMENT CONTROL (EPSC)

Standard permit conditions

1. Prior to any ground disturbing activity on the site, an initial inspection by City staff is required. EPSC Best Management Practices (BMPs) must be in place prior to the inspector arriving. Call (541) 791-0116 to schedule your inspection.
2. EPSC BMPs must be installed in such a manner as to ensure that sediment and sediment-laden water does not enter upon adjacent properties or rights-of-way, the stormwater system, wetlands, or Waters of the State.
3. EPSC BMPs shown on the plans are minimum requirements for anticipated site conditions. During the construction period, the EPSC measures shall be upgraded as needed for unexpected storm events and to ensure that sediment and sediment-laden water does not leave the site.
4. EPSC BMPs shall be inspected daily by the permit holder and maintained as necessary to ensure their function.
5. Stabilized gravel construction entrances shall be installed at the beginning of construction and maintained for the duration of the project. Additional measures may be required to ensure that all paved areas are kept clean for the duration of the project.
6. EPSC BMPs shall be kept in place until permanent ground cover is established.
7. Exposed soil must be permanently stabilized against wind and water erosion before the EPSC permit can be closed. Once the site is stabilized, schedule a final inspection by calling (541) 791-0116. Permanent soil stabilization includes landscaping, seeding, or covering exposed soil with a minimum 2-inch layer of bark or wood chips, per Section 2.3.3 of the EPSC Manual.
8. It is the property owner's responsibility to ensure that any proposed grading, fill, excavation, or other site work does not negatively impact drainage patterns to or from adjacent properties.

Wet Weather Season

- Wet weather BMPs will be in effect from October 1st through April 30th. However, the project site is required to manage runoff from the site year around.
- Rain is the driving factor behind most erosion in this region. Rainfall impact and surface water runoff over exposed soil dislodges sediment particles, suspending them in moving water. Saturated soils are more easily tracked off site by equipment.
- During the wet weather season or when rain is forecasted additional Erosion Prevention and Sediment Control BMPs are required. The project shall have these BMPs onsite and readily available year-round.

Where can I get assistance?

- We are here to help you. Staff are typically available from 8:00 am to 5:00 pm weekdays to answer your questions by phone at (541) 917-7676, and at the Public Works Department front counter in City Hall, 333 Broadalbin Street SW. We encourage you to call and make arrangements for a free on-site consultation.
- The City's GIS mapping service is available at: <https://infohub.cityofalbany.net/infohub/>
- Floodplain data can be obtained from FEMA at: <https://msc.fema.gov/portal/home>
- The City's EPSC Manual and related information found on the EPSC website: <https://albanyoregon.gov/pw/engineering/erosion-prevention-and-sediment-control>
- Sample Site Plan, attached.

City of Albany Public Works Department – Erosion Prevention & Sediment control
333 Broadalbin Street SW
(541) 917-7646



FIGURE 1
MAJOR EROSION PREVENTION
AND SEDIMENT CONTROL PLAN

JANUARY 2024

1"=500'

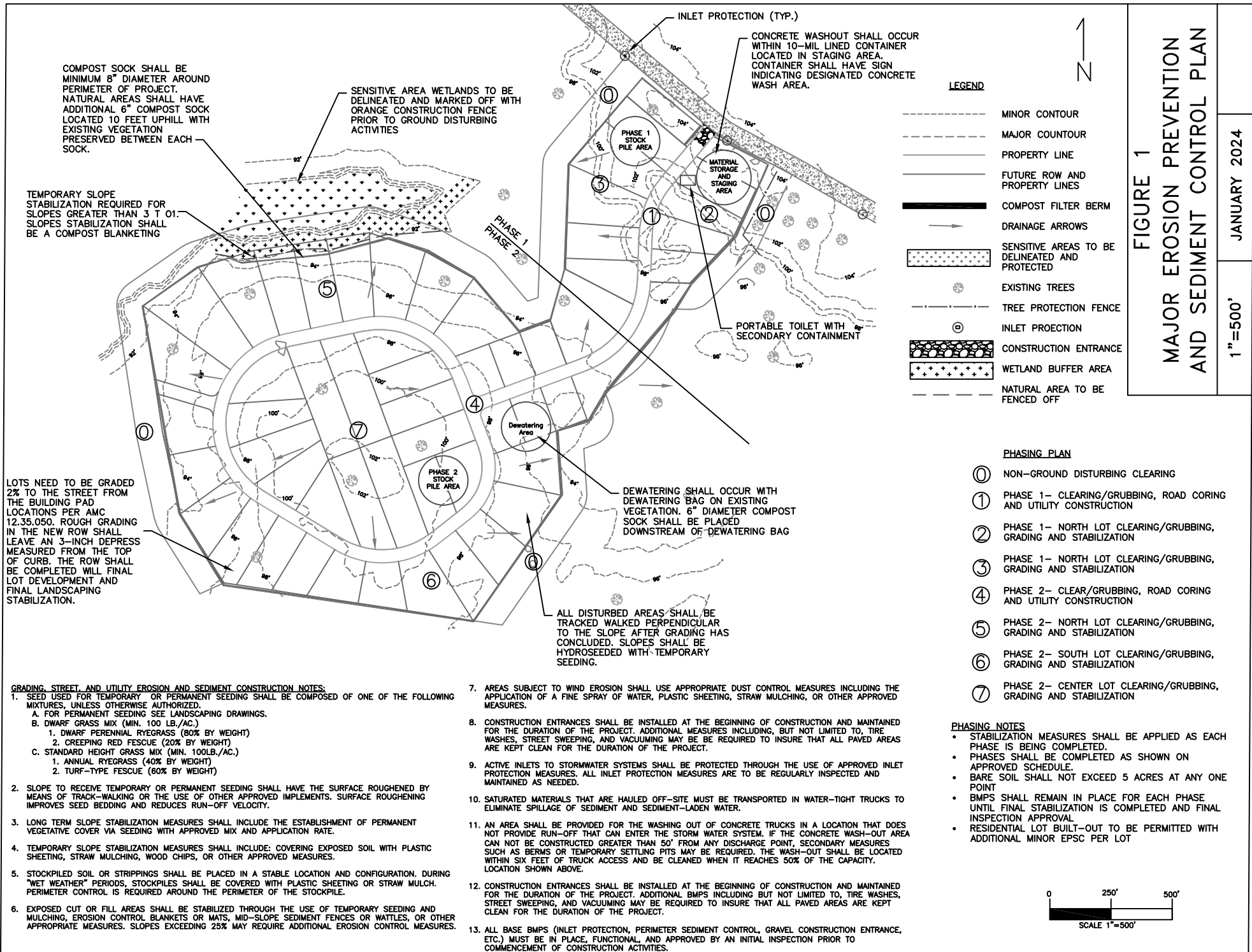

Appendix B

Contractor/Inspector Resources

Inspector Checklist

Erosion Control Monitoring Form

Rainfall Intensity, Duration, and Frequency Curve

Slope Conversion Table

Wood Fiber, Seed, or Fertilizer Hydraulic Application

**SAMPLE INSPECTOR CHECKLIST
FOR
EROSION CONTROL**

SCHEDULE

- Have you looked at the Contractors Schedule and determined any conflicts?
- Install necessary Best Management Practices (BMP's) prior to any earthwork beginning. Are earthwork operations being performed in October with soils that are highly erosive? Grubbing of areas that will be worked on much later should be delayed. Staging of project may require staging of erosion control measures. Is seeding scheduled before the end of the seed dates?
- Is there work in sensitive areas that may alter contractor's schedule?
- When will the contractor remove BMP's? Don't remove until seeded slopes are established.

EROSION PREVENTION AND SEDIMENT CONTROL PLAN

- Walk project during preliminary or advanced plan review and look for potential erosion problems
- Have you reviewed the Contractor's Erosion Prevention and Sediment Control Plan to determine if it is adequate or makes sense? The plan included in the bid package may need modifications to address site conditions or staging
- Walk project with ESCM prior to any earthwork looking for needed modifications of the plan. Is the plan being kept up-to-date? Is the plan kept on-site? Where?
- What is contractor's erosion control plan for offsite borrow sources and waste areas?

EROSION AND SEDIMENT CONTROL MANAGER (ESCM)

- Have you met and talked with the person identified as the ESCM?
- Is this person certified?
- Does this person understand all the required duties of the ESCM?
- Does this person have the authority to direct resources and make changes in an emergency situation?

SENSITIVE AREAS

- Are there sensitive areas, which require "extra" attention?
- Have they been adequately addressed on the EPSC plan?
- Will these sensitive areas require more monitoring?

CONTINGENCY PLAN

- Is there a contingency plan for unexpected events?
- What is the plan for stabilization of earthwork performed after seeding dates?

MATERIALS ON-HAND

- It may be difficult to get Erosion Control materials in the middle of the wet season. It is easier to deal with erosion before it happens rather than after.
- Does the Contractor have adequate materials on hand to cover each phase of work they plan on performing?
- Are installed erosion and sediment controls in good working order?
- Are catch basins cleaned out when more than 6 inches of sediment depth accumulates?
- Are sediment fences, barriers, check dams, inlet protection cleaned out when sediment reaches 1/3 of the storage depth?
- Are construction entrances maintained with fresh rock to prevent tracking of sediment onto pavement?

MONITORING FORMS

- Are you getting Erosion Control Weekly reports as often as they should be filed from the plan?
- Are the forms complete and adequately represent site conditions and work performed?
- Are forms on-site with the "Up-to-Date Plan"?

SLOPE PROTECTION & STABILIZATION

- Permanently finish slopes from top down and seed as you go! Track walk slopes to provide loosened soil and hold seed
- Temporarily stabilize unfinished earthwork scheduled for re-disturbance at a later date (i.e. straw mulch, chemical soil stabilizers, plastic sheeting, matting, etc.)

PLANS ARE ONLY GUIDE

What's best for your project is what works on your project. No designer can sit in an office and determine what works on your project. It may require trial and error. The plans are a toolbox with available tools. You may have to create and modify these tools to satisfy the conditions

IT'S NOT WORKING!!!

- Are the BMP' s working?
- If not, are the facilities attempting to prevent erosion before it starts?

ADDITIONAL ITEMS

- Go back to newly installed BMP's to check their performance
- How will contractor handle dust control or wind erosion?
- Will snow melt change runoff and drainage patterns?

Erosion Control Monitoring Form

Project Name: _____

Date: _____ Time: _____ Weather: _____

Rainfall In the Last 24 Hours: Yes No Estimated Quantity _____ (inches)

Site Active: Yes No Days Since Last Inspection: _____

Inspection Type: Initial Inspection Regular Inspection Final Active Storm Water Runoff Other
(if Other please provide description: _____)

Observations*:

Corrective Actions Taken/Needed*:

Have Any Changes Been Made to the ESCP: Yes No

If Yes, What Changes Have Been Made:

Have The Changes Been Documented (i.e. "Red Lines"): Yes No Action Plan: Yes No

Inspected By: Print Name: _____ Title: _____

Signature: _____

Additional Comment Space on Back

RAINFALL INTENSITY - DURATION - FREQUENCY CURVES

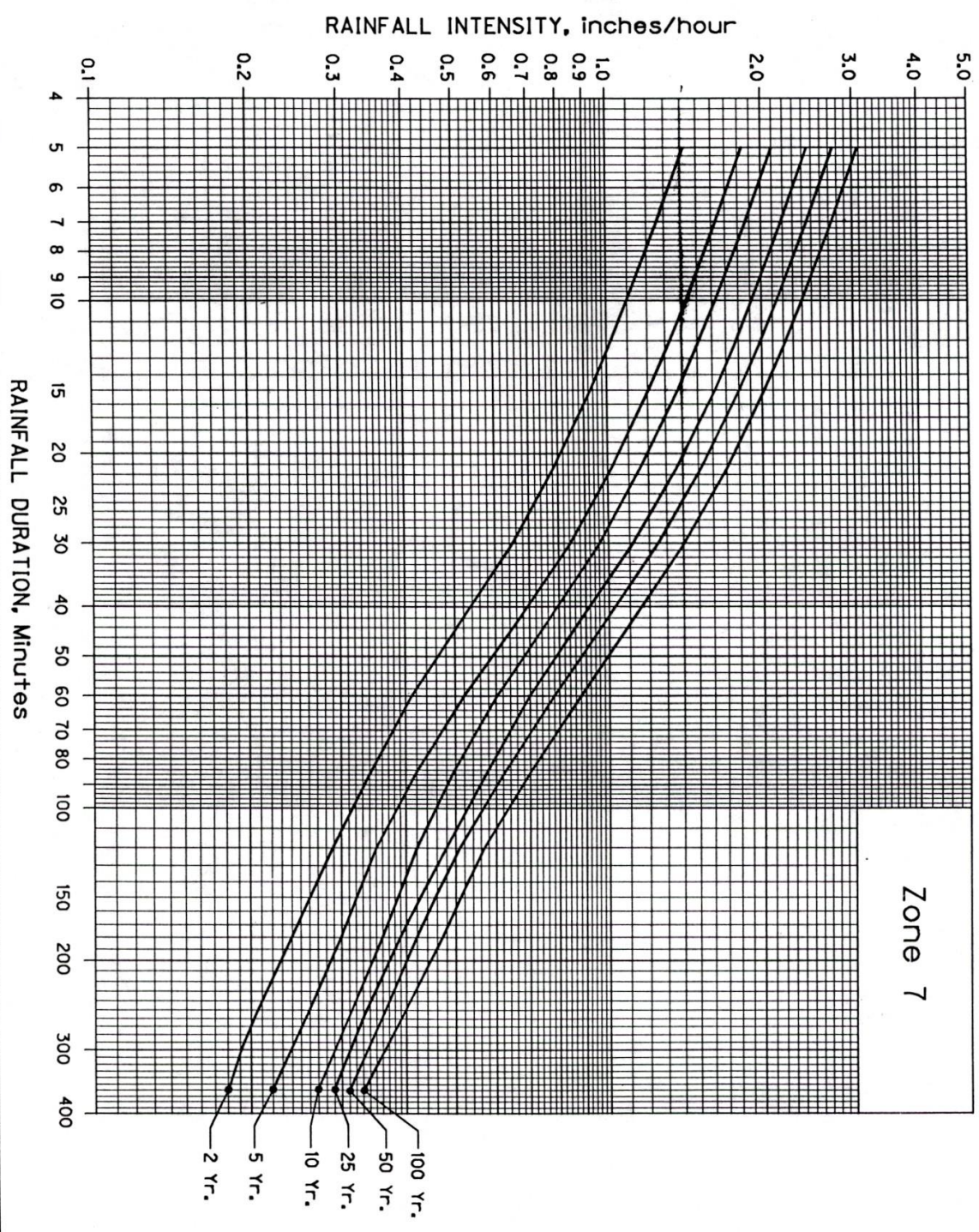

SLOPE CONVERSION TABLE

Horizontal:Vertical	% Grade	Angle Degree
100:1	1.0%	0.6
90:1	1.1%	0.6
80:1	1.3%	0.7
70:1	1.4%	0.8
60:1	1.7%	1.0
50:1	2.0%	1.1
40:1	2.5%	1.4
35:1	2.9%	1.6
30:1	3.3%	1.9
25:1	4.0%	2.3
20:1	5.0%	2.9
19:1	5.3%	3.0
18:1	5.6%	3.2
17:1	5.9%	3.4
16:1	6.3%	3.6
15:1	6.7%	3.8
14:1	7.1%	4.1
13:1	7.7%	4.4
12:1	8.3%	4.8
11:1	9.1%	5.2
10:1	10.0%	5.7
9:1	11.1%	6.3
8:1	12.5%	7.1
7:1	14.3%	8.1
6:1	16.7%	9.5
5:1	20.0%	11.3
4:1	25.0%	14.0
3:1	33.3%	18.4
2:1	50.0%	26.6
1:1	100.0%	45.0

HYDRAULIC APPLICATION

Wood Fiber Mulch Hydraulic Application

Average Water Required for Application

$$V_{wa} \text{ (gal)} = (W_{wf}) / (40 \text{ lbs mulch} / 100 \text{ gal water})$$

Maximum Water Required for Application

$$V_{wm} \text{ (gal)} = (W_{wf}) / (50 \text{ lbs mulch} / 100 \text{ gal water})$$

Area of Coverage

$$A \text{ (acre)} = (W_{wf} / R_{wf})$$

$$A \text{ (ft}^2\text{)} = (W_{wf} / R_{wf}) * (43,560 \text{ ft}^2\text{/acre})$$

Wood Fiber Application Rate (lb/acre)	R_{wf}
Weight or Mass of Wood Fiber (lbs)	W_{wf}
Average Water Requirement (gal)	V_{wa}
Maximum Water Requirement (gal)	V_{wm}
Area of Coverage (ft ²) & (acres)	A

Seed or Fertilizer Hydraulic Application

Area of Coverage

$$A \text{ (acre)} = (W_{sf} / R_{su})$$

$$A \text{ (ft}^2\text{)} = (W_{sf} / R_{su}) * (43,560 \text{ ft}^2\text{/acre})$$

Seed or Fertilizer Application Rates (lb/acre)	R_{sf}
Weight or Mass of Seed or Fertilizer (lbs)	W_{sf}
Area of Coverage (ft ²) & (acres)	A

HYDRAULIC APPLICATION

Example #1 (Mulch -Area of Coverage)

Given: Required mulch application rate 2,000 lb/acre.
Hydro Seeder with 1,800 gal working capacity.
900 lbs of Wood Fiber to be applied over seeded area.

Find: Range of Area of Coverage.

Answer: Find the 2,000 lb/acre Application Rate Chart, Table D-1.

Using a 50 lbs / 100 gal mulch/water ratio:

Find 1,800 gal in the Maximum Water Required for Application column.
Follow this row over to the area columns.
One tank can cover 0.45 acre (19,602 ft²).

Using a 40 lbs / 100 gal mulch/water ratio:

Find 1,800 gal in the Average Water Required for Application column, .
There isn't an 1,800 gal row, so interpolate between 1,750 gal and 2,000 gal.
Follow the 1,750 gal and 2,000 gal row over to the area columns.
At 1,750 gal, one tank can cover 0.35 acre (15,246 ft²).
At 2,000 gal, one tank can cover 0.40 acre (17,424 ft²).
One tank can cover $1,800 \text{ lb} * ((0.40 \text{ acre} - 0.35 \text{ acre}) / (2,000 \text{ gal} - 1,750 \text{ gal}))$
 $= 0.36 \text{ acre (15,682 ft}^2\text{)}$.

Example #2 (Mulch - Materials Used)

Given: 0.60 acre (26,136 fr) area to be seeded.
Required mulch application rate 1,200 lb/acre.
Hydro Seeder with 2,500 gal working capacity.

Find: A) Amount of Mulch Required in lbs.
B) Range of Water Required in gal.
C) Number of Trips Required.

Answer: Find the 2,000 lb/acre Application Rate Chart, Table D-2.

A) Find 0.60 acre under the Area of Coverage column.
Follow the row over to the Wood Fiber column.
The wood fiber required by the area is 1,200 lb.

B) Find 0.60 acre under the Area of Coverage column.
Follow the row to the Required Water for Application column.
Using a 50 lbs / 100 gal mulch/water ratio:
The water required for the area is 2,400 gal.
Using a 40 lbs / 100 gal mulch/water ratio:
The water required for the area is 3,000 gal.

C) Using a 50 lbs / 100 gal mulch/water ratio:
 $(2,400 \text{ gal} / (2,500 \text{ gal/trip})) = 1 \text{ trip}$
Using a 40 lbs / 100 gal mulch/water ratio:
 $(3,000 \text{ gal} / (2,500 \text{ gal/trip})) = 1.2 \text{ trips, so use 2 trips.}$

HYDRAULIC APPLICATION

Example #3 (Seed - Area of Coverage)

Given: Seed Application Rate 40 lb/acre.
200 lb of seed is to be applied.

Find: Area of Coverage.

Answer: Use the Seed or Fertilizer Hydraulic Application Chart, Table D-1.
Find the 40 lb/acre application rate column.
Find the 200 lb seed row.
Determine where the column and the row intersect and record the area.
For 40 lb/acre, the area of coverage is *5 acre (217,800 ft²)*.
Or
Use the Formula on the Hydraulic Application Equations Sheet.
Find the area of coverage equation under the title Seed or Fertilizer Hydraulic Application.
The area equation is $A \text{ (acre)} = W_{sf} / R_{sf}$
 $\text{Area (acre)} = (200 \text{ lb}) / (40 \text{ lb/acre}) = 5 \text{ acre}$.
 $\text{Area (ft}^2) = ((200 \text{ lb}) / (40 \text{ lb/acre})) * (43,560 \text{ ft}^2/\text{acre}) = 217,800 \text{ ft}^2$.

Example #4 (Seed - Materials Needed)

Given: Required Area of Coverage
0.13 acre (5,662.8 ft²).
Seed Application Rate 200 lb/acre.

Find: Amount of Seed Required in lbs.

Answer: Use the Seed or Fertilizer Hydraulic Application Chart, Table D-1.
Find the 200 lb/acre application rate column.
Move down the list of areas to 0.13 acre.
0.13 acre is not in this column, so interpolate.
Find the area above and below 0.13 acre.
Follow the row from the area to the Amount of Seed column.
For 0.10 acre (4,356 ft²), the amount of seed is *20 lbs*.
For 0.15 acre (6,534 ft²), the amount of seed is *30 lbs*.
At 0.13 acre (5,662.8 ft²), the amount of seed is
 $0.13 \text{ acre} * ((30 \text{ lb} - 20 \text{ lb}) / (0.15 \text{ acre} - 0.10 \text{ acre})) = 26 \text{ lbs}$.
Or
Use the Formula on the Hydraulic Application Equations Sheet.
Find the area of coverage equation under the title Seed or Fertilizer Hydraulic Application.
The area equation is $A \text{ (acre)} = W_{sf} / R_{sf}$
Rearrange the equation so $W_{sf} \text{ (lb)} = (A) * (R_{sf})$
 $W_{sf} \text{ (lb)} = (0.13 \text{ acre}) * (200 \text{ lb/acre}) = 26 \text{ lbs}$.

Seed or Fertilizer Hydraulic Application

Application Load		Area of Coverage (A)														
		Application Rates of Pure Live Seed (R _{sf})														
(W _{sf})	20 lb/acre	40 lb/acre	60 lb/acre	80 lb/acre	100 lb/acre	200 lb/acre	400 lb/acre	20 lb/acre	40 lb/acre	60 lb/acre	80 lb/acre	100 lb/acre	200 lb/acre	400 lb/acre		
Pounds	acre	ft ²	acre	ft ²	acre	ft ²	acre	ft ²	acre	ft ²	acre	ft ²	acre	ft ²	acre	ft ²
10	0.50	21780	0.25	10,890	0.17	7,260	0.13	5,450	0.10	4,360	0.05	2,180	0.03	1,090		
20	1.00	43560	0.50	21,780	0.33	14,520	0.25	10,890	0.20	8,710	0.10	4,360	0.05	2,180		
30	1.50	65340	0.75	32,670	0.50	21,780	0.38	16,340	0.30	13,070	0.15	6,530	0.08	3,270		
40	2.00	87120	1.00	43,560	0.67	29,040	0.50	21,780	0.40	17,420	0.20	8,710	0.10	4,360		
50	2.50	108900	1.25	54,450	0.83	36,300	0.63	27,230	0.50	21,780	0.25	10,890	0.13	5,450		
60	3.00	130680	1.50	65,340	1.00	43,560	0.75	32,670	0.60	26,140	0.30	13,070	0.15	6,530		
70	3.50	152460	1.75	76,230	1.17	50,820	0.88	38,120	0.70	30,490	0.35	15,250	0.18	7,620		
80	4.00	174240	2.00	87,120	1.33	58,080	1.00	43,560	0.80	34,850	0.40	17,420	0.20	8,710		
90	4.50	196020	2.25	98,010	1.50	65,340	1.13	49,010	0.90	39,200	0.45	19,600	0.23	9,800		
100	5.00	217800	2.50	108,900	1.67	72,600	1.25	54,450	1.00	43,560	0.50	21,780	0.25	10,890		
120	6.00	261360	3.00	130,680	2.00	87,120	1.38	59,900	1.20	52,270	0.60	26,140	0.30	13,070		
140	7.00	304920	3.50	152,460	2.33	101,640	1.50	65,340	1.40	60,980	0.70	30,490	0.35	15,250		
160	8.00	348480	4.00	174,240	2.67	116,160	1.75	76,230	1.60	69,700	0.80	34,850	0.40	17,420		
180	9.00	392040	4.50	196,020	3.00	130,680	2.00	87,120	1.80	78,410	0.90	39,200	0.45	19,600		
200	10.00	435600	5.00	217,800	3.33	145,200	2.25	98,010	2.00	87,120	1.00	43,560	0.50	21,780		
220	11.00	479160	5.50	239,580	3.67	159,720	2.50	108,900	2.20	95,830	1.10	47,920	0.55	23,960		
240	12.00	522720	6.00	261,360	4.00	174,240	2.75	119,790	2.40	104,540	1.20	52,270	0.60	26,140		
260	13.00	566280	6.50	283,140	4.33	188,760	3.00	130,680	2.60	113,260	1.30	56,630	0.65	28,310		
280	14.00	609840	7.00	304,920	4.67	203,280	3.25	141,570	2.80	121,970	1.40	60,980	0.70	30,490		
300	15.00	653400	7.50	326,700	5.00	217,800	3.50	152,460	3.00	130,680	1.50	65,340	0.75	32,670		

Table A-1

Seed or Fertilizer Hydraulic Application

Application Load		Area of Coverage (A)																	
		Application Rates of Pure Live Seed (R _{sl})																	
(W _{sl})	Pounds	20 lb/acre		40 lb/acre		60 lb/acre		80 lb/acre		100 lb/acre		200 lb/acre		400 lb/acre					
		acre	ft ²	acre	ft ²	acre	ft ²	acre	ft ²	acre	ft ²	acre	ft ²	acre	ft ²				
10	0.50	21780	10,890	0.25	7,260	0.17	5,450	0.13	4,360	0.10	3,270	0.05	2,180	0.03	1,090				
20	1.00	43560	21,780	0.50	14,520	0.33	10,890	0.25	8,710	0.20	6,530	0.10	4,360	0.05	2,180				
30	1.50	65340	32,670	0.75	21,780	0.50	16,340	0.38	13,070	0.30	10,890	0.15	6,530	0.08	3,270				
40	2.00	87120	43,560	1.00	29,040	0.67	21,780	0.50	17,420	0.40	13,070	0.20	8,710	0.10	4,360				
50	2.50	108900	54,450	1.25	36,300	0.83	27,230	0.63	21,780	0.50	17,420	0.25	10,890	0.13	5,450				
60	3.00	130680	65,340	1.50	43,560	1.00	32,670	0.75	26,140	0.60	21,780	0.30	13,070	0.15	6,530				
70	3.50	152460	76,230	1.75	50,820	1.17	38,120	0.88	30,490	0.70	26,140	0.35	15,250	0.18	7,620				
80	4.00	174240	87,120	2.00	58,080	1.33	43,560	1.00	34,850	0.80	30,490	0.40	17,420	0.20	8,710				
90	4.50	196020	98,010	2.25	65,340	1.50	49,010	1.13	39,200	0.90	34,850	0.45	19,600	0.23	9,800				
100	5.00	217800	108,900	2.50	72,600	1.67	54,450	1.25	43,560	1.00	39,200	0.50	21,780	0.25	10,890				
120	6.00	261360	130,680	3.00	87,120	2.00	65,340	1.38	50,820	1.20	43,560	0.60	26,140	0.30	13,070				
140	7.00	304920	152,460	3.50	101,640	2.33	76,230	1.50	58,080	1.40	49,010	0.70	30,490	0.35	15,250				
160	8.00	348480	174,240	4.00	116,160	2.67	87,120	1.75	65,340	1.60	54,450	0.80	34,850	0.40	17,420				
180	9.00	392040	196,020	4.50	130,680	3.00	98,010	2.00	72,600	1.80	61,620	0.90	39,200	0.45	19,600				
200	10.00	435600	217,800	5.00	145,200	3.33	108,900	2.25	87,120	2.00	72,600	1.00	43,560	0.50	21,780				
220	11.00	479160	239,580	5.50	159,720	3.67	119,790	2.50	98,010	2.20	87,120	1.10	47,920	0.55	23,960				
240	12.00	522720	261,360	6.00	174,240	4.00	119,790	2.75	108,900	2.40	98,010	1.20	52,270	0.60	26,140				
260	13.00	566280	283,140	6.50	188,760	4.33	130,680	3.00	119,790	2.60	108,900	1.30	56,630	0.65	28,310				
280	14.00	609840	304,920	7.00	203,280	4.67	130,680	3.25	130,680	2.80	119,790	1.40	60,980	0.70	30,490				
300	15.00	653400	326,700	7.50	217,800	5.00	141,570	3.50	141,570	3.00	130,680	1.50	65,340	0.75	32,670				

Wood Fiber Mulch draulic Application

Table C-1 **500 lb/acre Application Rate (R_{wf})**

Wood Fiber (W _{wf}) Pounds	Water Required for Application		Area of Coverage (A)	
	Average (V _{wa}) 40 lbs mulch / 100 gal water *Gallons	Maximum (V _{wm}) 50 lbs mulch / 100 gal water *Gallons	ft ²	Acres
500	1,250	1,000	43,560	1.00
600	1,500	1,200	52,272	1.20
700	1,750	1,400	60,984	1.40
800	2,000	1,600	69,696	1.60
900	2,250	1,800	78,408	1.80
1,000	2,500	2,000	87,120	2.00
1,100	2,750	2,200	95,832	2.20
1,200	3,000	2,400	104,544	2.40
1,300	—	2,600	113,256	2.60
1,400	—	2,800	121,968	2.80
1,500	—	3,000	130,680	3.00

Table C-2 **1,500 lb/acre Application Rate (R_{wf})**

Wood Fiber (W _{wf}) Pounds	Water Required for Application		Area of Coverage (A)	
	Average (V _{wa}) 40 lbs mulch / 100 gal water *Gallons	Maximum (V _{wm}) 50 lbs mulch / 100 gal water *Gallons	ft ²	Acres
500	1,250	1,000	14,520	0.33
600	1,500	1,200	17,424	0.40
700	1,750	1,400	20,328	0.47
800	2,000	1,600	23,232	0.53
900	2,250	1,800	26,136	0.60
1,000	2,500	2,000	29,041	0.67
1,100	2,750	2,200	31,945	0.73
1,200	3,000	2,400	34,849	0.80
1,300	—	2,600	37,753	0.87
1,400	—	2,800	40,657	0.93
1,500	—	3,000	43,561	1.00

Wood Fiber Mulch Hydraulic Application

Table C-3 2,000 lb/acre Application Rate (Rwf)

Wood Fiber (Wwft) Pounds	Water Required for Application		Area of Coverage (A)	
	Average (Vwa) 40 lbs mulch / 100 gal water *Gallons	Maximum (Vwm) 50 lbs mulch / 100 gal water *Gallons	ft ²	Acres
500	1,250	1,000	10,890	0.25
600	1,500	1,200	13,068	0.30
700	1,750	1,400	15,246	0.35
800	2,000	1,600	17,424	0.40
900	2,250	1,800	19,602	0.45
1,000	2,500	2,000	21,780	0.50
1,100	2,750	2,200	23,958	0.55
1,200	3,000	2,400	26,136	0.60
1,300	—	2,600	28,314	0.65
1,400	—	2,800	30,492	0.70
1,500	—	3,000	32,670	0.75

Table C-4 2,500 lb/acre Application Rate (Rwf)

Wood Fiber (Wwft) Pounds	Water Required for Application		Area of Coverage (A)	
	Average (Vwa) 40 lbs mulch / 100 gal water *Gallons	Maximum (Vwm) 50 lbs mulch / 100 gal water *Gallons	ft ²	Acres
500	1,250	1,000	8,712	0.20
600	1,500	1,200	10,454	0.24
700	1,750	1,400	12,197	0.28
800	2,000	1,600	13,939	0.32
900	2,250	1,800	15,682	0.36
1,000	2,500	2,000	17,424	0.40
1,100	2,750	2,200	19,166	0.44
1,200	3,000	2,400	20,909	0.48
1,300	—	2,600	22,651	0.52
1,400	—	2,800	24,394	0.56
1,500	—	3,000	26,136	0.60

Wood Fiber Mulch Hydraulic Application

Table C-1 500 lb/acre Application Rate (R_{wf})

Wood Fiber (W _{wf}) Pounds	Water Required for Application		Area of Coverage (A)	
	Average (V _{wa}) 40 lbs mulch / 100 gal water *Gallons	Maximum (V _{wm}) 50 lbs mulch / 100 gal water *Gallons	ft ²	Acres
500	1,250	1,000	43,560	1.00
600	1,500	1,200	52,272	1.20
700	1,750	1,400	60,984	1.40
800	2,000	1,600	69,696	1.60
900	2,250	1,800	78,408	1.80
1,000	2,500	2,000	87,120	2.00
1,100	2,750	2,200	95,832	2.20
1,200	3,000	2,400	104,544	2.40
1,300	—	2,600	113,256	2.60
1,400	—	2,800	121,968	2.80
1,500	—	3,000	130,680	3.00

Table C-2 1,500 lb/acre Application Rate (R_{wf})

Wood Fiber (W _{wf}) Pounds	Water Required for Application		Area of Coverage (A)	
	Average (V _{wa}) 40 lbs mulch / 100 gal water *Gallons	Maximum (V _{wm}) 50 lbs mulch / 100 gal water *Gallons	ft ²	Acres
500	1,250	1,000	14,520	0.33
600	1,500	1,200	17,424	0.40
700	1,750	1,400	20,328	0.47
800	2,000	1,600	23,232	0.53
900	2,250	1,800	26,136	0.60
1,000	2,500	2,000	29,041	0.67
1,100	2,750	2,200	31,945	0.73
1,200	3,000	2,400	34,849	0.80
1,300	—	2,600	37,753	0.87
1,400	—	2,800	40,657	0.93
1,500	—	3,000	43,561	1.00

Wood Fiber Mulch Hydraulic Application

Table C-3 2,000 lb/acre Application Rate (Rwrf)

Wood Fiber (Wwrf) Pounds	Water Required for Application		Area of Coverage (A)	
	Average (Vwa) 40 lbs mulch / 100 gal water *Gallons	Maximum (Vwm) 50 lbs mulch / 100 gal water *Gallons	ft ²	Acres
500	1,250	1,000	10,890	0.25
600	1,500	1,200	13,068	0.30
700	1,750	1,400	15,246	0.35
800	2,000	1,600	17,424	0.40
900	2,250	1,800	19,602	0.45
1,000	2,500	2,000	21,780	0.50
1,100	2,750	2,200	23,958	0.55
1,200	3,000	2,400	26,136	0.60
1,300	—	2,600	28,314	0.65
1,400	—	2,800	30,492	0.70
1,500	—	3,000	32,670	0.75

Table C-4 2,500 lb/acre Application Rate (Rwrf)

Wood Fiber (Wwrf) Pounds	Water Required for Application		Area of Coverage (A)	
	Average (Vwa) 40 lbs mulch / 100 gal water *Gallons	Maximum (Vwm) 50 lbs mulch / 100 gal water *Gallons	ft ²	Acres
500	1,250	1,000	8,712	0.20
600	1,500	1,200	10,454	0.24
700	1,750	1,400	12,197	0.28
800	2,000	1,600	13,939	0.32
900	2,250	1,800	15,682	0.36
1,000	2,500	2,000	17,424	0.40
1,100	2,750	2,200	19,166	0.44
1,200	3,000	2,400	20,909	0.48
1,300	—	2,600	22,651	0.52
1,400	—	2,800	24,394	0.56
1,500	—	3,000	26,136	0.60

Appendix C

Glossary

Appendix C

Glossary of Terms

Absorption – The adhesion of a substance to the surface of a solid or liquid. Heavy metals such as zinc and lead often adsorb onto particles.

Accelerated Erosion – Erosion much more rapid than normal or geologic erosion, primarily as a result of the activities of man.

Alluvial Soils – Soils developed from transported and relatively recently deposited material (alluvium) characterized by a weak modification (or none) of the original material by soil-forming processes.

Alluvium – A general term for all detrital material deposited or in transit by streams, including gravel, sand, silt, clay, and all variations and mixtures of these. Unless otherwise noted, alluvium is unconsolidated.

Anadromous – Fishes which ascend rivers from the sea for breeding.

Annual Storm – The highest peak storm discharge that is expected in any given year.

Apron – A pad of non-erosive material designed to prevent scour holes developing at the outlet ends of culverts, outlet pipes, grade stabilization structures, and other water control devices.

Aquifer – An underground porous, water-bearing geological formation. The term is generally restricted to materials capable of yielding an appreciable supply of water.

Barrel – A conduit placed through a dam, levee, or a dike to control the release of water.

Base Flow – Stream discharge derived from groundwater sources as differentiated from surface runoff. Sometimes considered to include flows from regulated lakes or reservoirs.

Bearing Capacity – The maximum load that a material can support before failing.

Bedrock – The more or less solid rock in place either on or beneath the surface of the earth. It may be soft, medium, or hard and have a smooth or irregular surface.

Berm – A constructed barrier of compacted earth.

Best Management Practices (BMP's) – Physical, structural and/or managerial practices employed to avoid or mitigate damage or potential damage from the contamination or pollution of surface waters or wetlands. Structural BMP's are actual physical installations rather than procedural/managerial BMP's, such as good housekeeping and employee training.

Capillary Action – The tendency of drier soil particles to attract moisture from wetter portions of soil.

GLOSSARY OF TERMS (CONTINUED)

Catch Basin – A grated inlet, curb opening or combination inlet with or without a sump which admits storm water to a sewer or subdrain.

CD – Cross machine direction; direction perpendicular to the machine or manufacture direction.

Channel erosion – The erosion process whereby the volume and velocity of flow wears away the bed and/or banks of a well-defined channel.

Channel Stabilization – Protecting the sides and bed of a channel from erosion by controlling flow velocities and flow directions using jetties, drops or other structures and/or by lining the channel with a suitable liner such as vegetation, riprap, concrete, or other similar material.

Channel – A natural stream or excavated ditch that conveys water.

Channelization – Alteration of a stream channel by widening, deepening, straightening, or paving certain areas to improve flow characteristics.

Check Dam – A small dam constructed in a gully or other small watercourse to decrease flow velocity, minimize channel scour, and promote sediment deposition.

Chute – A high-velocity, open channel for conveying water down a steep slope without erosion, usually paved.

Classification – The official classification of soil materials and soil aggregate mixtures for highway construction used by the American Association of State Highway and Transportation Officials.

Clay – (1) Soil fraction consisting of particles less than 0.002 mm in diameter. (2) A soil texture class which is dominated by clay or at least has a larger proportion of clay than either silt or sand.

Cohesion – The capacity of a soil to resist shearing stress, exclusive of functional resistance.

Cohesive Soil – A soil that, when unconfined, has considerable strength when air-dried and significant strength when saturated.

Coir – Fiber made from coconut husks.

Compost – Organic residue or a mixture of organic residues and soil, that has undergone biological decomposition until it has become relatively stable humus.

Contour – An imaginary line on the surface of the earth connecting points of the same elevation.

Conventional Pollutants – Contaminants (other than nutrients) such as sediment, oil, and vehicle fluids.

Cut – Portion of ground surface or area from which earth has been removed or will be removed by excavating; the depth below the original ground surface to the excavated surface.

GLOSSARY OF TERMS (CONTINUED)

Cut-and-Fill – Process of earth grading by excavating part of a higher area and using the excavated material for fill to raise the surface of an adjacent lower area.

Cutoff Trench – A long, narrow excavation (keyway) constructed along the center line of a dam, dike, levee, or embankment and filled with relatively impervious material intended to reduce seepage of water through porous strata.

Cutting – A leaf, stem or branch cut from a plant to establish a new plant.

Design Highwater – The elevation of the water surface at peak flow conditions of the design flood. D

Design Life – The period of time for which a facility is expected to perform its intended function.

Design Storm – Selected storm of a given frequency used for designing a design storm system. Hypothetical storm derived from intensity- duration-frequency curves. A prescribed hydrograph and total precipitation amount (for a specific duration recurrence frequency) used to estimate runoff in order to analyze existing drainage, design new drainage facilities or assess impacts of a proposed project on surface water flow.

Desilting Area – An area of grass, shrubs, or other vegetation used for including deposition of silt and other debris from flowing water; located above a stock tank, pond, field, or other area needing protection from sediment accumulation.

Detention Facility – An above or below ground facility, such as a pond or tank, which temporarily stores storm water runoff and releases it at a controlled rate. There is little or no infiltration of the stored storm water.

Detention Time – The theoretical time required to displace the contents of a tank or unit at a given rate of discharge (volume divided by rate of discharge).

Detention – Storage and subsequent release of excess storm water runoff.

Dewatering – The removal of water temporarily impounded in a holding basin.

Dike – An embankment to confine or control water, often built along the banks of a river to prevent overflow of lowlands; a levee.

Discharge – Usually the rate of water flow; a volume of fluid passing a point per unit time commonly expressed as cubic feet per second, cubic meters per second, gallons per minute, or millions of gallons per day.

Dispersion, Soil – The breaking down of fine soil aggregates into individual particles, resulting in single-grain structure. Ease of dispersion influences the erodibility of soils. Generally speaking, the more easily dispersed the soil, the more erodible it is.

Diversion Dike – A barrier built to divert surface runoff.

GLOSSARY OF TERMS (CONTINUED)

Diversion – A channel with a supporting ridge on the lower side constructed at the top, across, or at the bottom of a slope for the purpose of controlling surface runoff.

Drain – A buried slotted or perforated pipe or other conduit (subsurface drain) or a ditch (open drain) for carrying off surplus groundwater or surface water.

Drainage – The removal of excess surface water or groundwater from land by means of ditches or subsurface drains.

Drainageway – A natural or artificial depression that carries surface water to a larger watercourse or outlet such as a river, lake, or bay.

Drop Inlet – Overall structure in which the water drops through a vertical riser connected to a discharge conduit or storm sewer.

Drop Spillway – Overall structure in which the water drops over a vertical wall onto an apron at a lower elevation.

Dry Pond – A facility which provides storm water quantity control by detaining runoff in a detention basin, then releasing the runoff at allowable rates.

Elongation The increase in length produced in the gage length produced by a tensile load.

Embankment A man-made deposit of soil, rock, or other material often used to form an impoundment.

Emergency Spillway Usually a vegetated earth channel used to safely convey flood discharges around an impoundment structure.

Energy Dissipater A device used to reduce the energy of flowing water to prevent erosion.

Environment The sum total of all the external conditions that may act upon a living organism or community to influence its development or existence.

Erodibility Susceptibility to erosion.

Erosion Prevention and Sediment Control Plan (EPSC plan) – Plans, specification and BMP details intended to prevent and control erosion and sediment related to the project construction activities.

Erosion Prevention and Sediment Control – Any temporary or permanent measures taken to reduce erosion, control siltation and sedimentation, and ensure that sediment- laden water does not leave a site.

Erosion The wearing away of the land surface by water, wind, ice, gravity, or other geological agents. The following terms are used to describe different types of water erosion:

GLOSSARY OF TERMS (CONTINUED)

Estuary – Area where fresh water meets salt water, (e.g. bays, mouths of rivers, salt marshes and lagoons). Estuaries serve as spawning and feeding grounds for large numbers of marine organisms and provide shelter and food for birds and wildlife.

Evapotranspiration – The combined loss of water from an area by evaporation from the soil surface and by transpiration of plants.

Excess Rainfall – The amount of rainfall that runs directly off an area.

Filter Blanket – A layer of sand and/or gravel designed to prevent the movement of fine-grained soils

Filter Fabric – A woven or non-woven, water permeable material generally made of synthetic products such as polypropylene and used in erosion and sediment control applications to trap sediment or prevent the movement of fine soil particles. Often used instead of a filter blanket.

Flood Peak – The highest stage or greatest discharge attained by a flood event. Thus, peak stage or peak discharge.

Flood Stage – The stage at which overflow of the natural banks of a stream begins.

Floodplain – The lowland that borders a stream and is subject to flooding when the stream overflows its banks.

Floodway – A channel, either natural, excavated, or bounded by dikes and levees, used to carry flood flows.

Flume – A constructed channel lined with erosion-resistant materials used to convey water on steep grades without erosion.

Fluvial Sediment – Those deposits produced by stream or river action.

Foundation Drain – A pipe or series of pipes which collects groundwater from the foundation or footing of structures to improve stability.

Freeboard – Vertical clearance between the normal operating level and the top side of an open conduit or channel. Vertical distance between the design water surface elevation and the elevation of the barrier retaining the water.

Frequency of Storm (design storm frequency) – The anticipated period in years that will elapse before another storm of equal intensity and/or total volume will recur: a 10-year storm can be expected to occur on the average once every 10 years.

Gabion – A wire mesh cage, usually rectangular, filled with rock and used to protect channel banks and other sloping areas from erosion.

Gauge – Device for measuring precipitation, water level, discharge, velocity, pressure, temperature, etc., e.g., a rain gauge. A measure of the thickness of metal, e.g., diameter of wire or wall thickness of steel pipe.

GLOSSARY OF TERMS (CONTINUED)

Geotextile – Any permeable textile used with foundation, rock, earth, or any other geotechnical engineering-related material as an integral part of a human-made project, structure, or system.

Grade Stabilization Structure – A structure for the purpose of stabilizing the grade of a gully or other watercourse, thereby preventing further head-cutting or lowering of the channel bottom.

Grade – (1) The slope of a road, a channel, or natural ground. (2) The finished surface of canal, bed, roadbed, top of embankment, or bottom of excavation; any surface prepared to a design elevation for the support of construction such as paving or the laying of a conduit. (3) To finish the surface of a canal bed, roadbed, top of embankment, or bottom of excavation, or other land area to a smooth, even condition.

Gradient – Change of elevation, velocity, pressure, or other characteristics per unit length; slope.

Grading – The cutting and/or filling of the land surface to a desired slope or elevation.

Grass – A member of the botanical family Gramineae, characterized by blade-like leaves that originate as a sheath wrapped around the stem.

Grassed Waterway – A natural or constructed waterway, usually broad and shallow, covered with erosion-resistant grasses and used to safely conduct surface water from an area.

Ground Cover (Horticulture) – Low-growing, spreading plants useful for low-maintenance landscape areas.

Gully erosion – The erosion process whereby runoff water accumulates in narrow channels and, over relatively short periods, removes the soil to considerable depths, ranging from 1 to 2 feet to as much as 75 to 100 feet.

Habitat – The environment in which the life needs of a plant or animal are supplied.

Harmful Pollutant – A substance which has adverse effects on an organism. Adverse effects include immediate death, chronic poisoning, impaired reproduction, and other conditions.

Head Loss – Energy loss due to friction, eddies, changes in velocity, elevation, or direction of flow.

Head – The height of water above any plain of reference. The energy, either kinetic or potential, possessed by each unit weight of a liquid, expressed as the vertical height through which a unit weight would have to fall to release the average energy possessed. Used in various compound terms such as pressure head or velocity head.

Headwater – The source of a stream. The water upstream from a structure or point on a stream.

Heavy Metals – Metals having a high specific gravity, present in municipal and industrial wastes, that pose long-term environmental hazards. Such metals include cadmium, chromium, cobalt, copper, lead, mercury, nickel, and zinc.

GLOSSARY OF TERMS (CONTINUED)

Hydrologic Cycle – The circuit of water movement from the atmosphere to the earth and back to the atmosphere through various stages or processes such as precipitation, interception, runoff, infiltration, percolation, storage, evaporation, and transpiration.

Hydrology – The science of the behavior of water in the atmosphere; on the surface of the earth, and underground.

Hyetograph – A graph of runoff rate, inflow rate or discharge rate past a specific point in time. A graph of flow versus time.

Impact Basin – A device used to dissipate the energy of flowing water to reduce erosion. Generally constructed of concrete partially submerged with baffles to dissipate velocities.

Impervious – A surface which water cannot easily penetrate. Can include graveled surface as well as paved surfaces.

Material Safety Data Sheets – Data sheets which come with materials. The sheets contain (MSDS) information such as pH, flashpoint, reactivity, first aid recommendations and indicate material classification and handling requirements.

MD – Machine direction; in textiles, the direction in a machine-made fabric parallel to the direction the fabric followed in the manufacturing machine.

Mean Depth – Average depth; cross-sectional area of stream or channel divided by its surface or top width.

Mean Velocity – The average velocity of a stream flowing in a channel or conduit at a given cross-section or in a given reach. It is equal to the discharge divided by the cross-section area of the reach.

Microclimate – The climate specifically associated with a very small area such as a crevice in a rock outcropping.

Mitigation – Means, in the following order of importance:

1. A voiding the impact altogether by not taking a certain action or part of an action
2. Minimizing impacts by limiting the degree or magnitude of the action and its implementation, by using appropriate technology, or by taking affirmative steps to avoid or reduce impacts.
3. Rectifying the impact by repairing, rehabilitating, or restoring the affected environment.
4. Reducing or eliminating the impact over time by preservation and maintenance operations during the life of the action and
5. Compensation for the impact by replacing, enhancing, or providing substitute resources or environments.

Mulch – A natural or artificial layer of plant residue or other materials covering the land surface which conserves moisture, holds soil in place, aids in establishing plant cover, and minimizes temperature fluctuations.

GLOSSARY OF TERMS (CONTINUED)

National Pollutant Discharge Elimination System (NPDES) – The part of the Federal Clean Water Act which requires permits (NPDES permits) for point and nonpoint source discharges.

Natural Drainage – The flow patterns of storm water runoff over the land in its pre- development state.

Nitrogen Fixation – The conversion of atmospheric nitrogen into stable compounds usable by plants. Carried out by bacteria that colonize the roots of most legumes.

Nonpoint Source Pollution – Pollution that enters a water body from diffuse origins on the watershed and does not result from discernible, confined, or discrete conveyances.

Normal Depth – Depth of flow in an open conduit during uniform flow for the given conditions.

Nutrients – Essential chemicals for plant and animal growth. Excessive amounts can lead to water quality degradation and algae blooms. Some nutrients are toxic at high concentrations.

Open Drain – Natural watercourse or constructed open channel that conveys drainage water.

Orifice – An opening with closed perimeter, usually of regular form, through which water may flow, generally to control outlet flow.

Outfall – The point, location, or structure where wastewater or drainage discharge from a sewer to a receiving body of water.

Outlet Channel – A waterway constructed or altered primarily to carry water from man-made structures, such as smaller channels, tiles, lines, and diversions.

Outlet – Point of water disposal from a stream, river, lake, tidewater, or artificial drain.

Peak Discharge – The maximum, instantaneous flow rate during a storm, usually in ~ reference to a specific design storm event.

Permeability Rate – The rate at which water will move through a saturated soil. Permeability rates are classified as follows:

1. Very slow - Less than 0.06 inches per hour.
2. Slow - 0.06 to 0.20 inches per hour.
3. Moderately slow - 0.20 to 0.63 inches per hour.
4. Moderate - 0.63 to 2.0 inches per hour.
5. Rapid - 6.3 to 20.0 inches per hour.
6. Very rapid - More than 20.0 inches per hour.

Permeability – A generic term for the ability of a material to conduct a fluid.

GLOSSARY OF TERMS (CONTINUED)

Permeable Soils – Soil materials with filtration rate of 10 minutes per inch or better. Such soils allow infiltration and reduce or eliminate surface and storm water runoff. Classified as SCS (Soil Conservation Services) Type A.

Permittivity – For a geotextile, the volumetric flow rate of water per unit cross- y section area, per unit head, under laminar flow conditions, in the normal direction through the fabric.

Pervious – Allowing movement of water.

pH – A numerical measure of hydrogen ion activity. The neutral point is pH 7.0. All pH values below 7.0 are acid and all above 7.0 are alkaline.

Plastic Limit – The moisture content at which a soil changes from a semi-solid to a plastic state.

Plasticity Index – The numerical difference between the liquid limit and the plastic limit of soil; the range of moisture content within which the soil remains plastic.

Point Source Pollutants – Pollution which enters a water body resulting from discernible confined or discrete conveyances.

Point Source – Any discernible, confined, and discrete conveyance, including but not limited to any pipe ditch, channel, tunnel, conduit, well, discrete fissure, container, rolling stock, concentrated animal feeding operation, or vessel or other floating craft, from which pollutants are or may be discharged.

Pollution Control Plan (PCP) – Consists of Pollution Control Plan form, narrative, site map and details describing measures to prevent pollution related to contractor activities.

Porosity – The volume of pore space in soil or rock.

Rainfall Intensity – The rate at which rain is falling at any given instant, usually expressed in inches per hour.

Rational Method – A means of computing storm drainage flow rates, Q , by use of the formula $Q=CIA$, where C is a coefficient describing the physical drainage area, I is the rainfall intensity and A is the area.

Receiving Stream – The body of water into which runoff or effluent is discharged.

Recharge Basin – A basin provided to increase infiltration for the purpose of replenishing groundwater supply.

Retention Structure – A natural or artificial basin that functions similar to a detention structure except that it maintains a permanent water supply.

Retention – The process of collecting and holding surface and storm water runoff with no surface overflow.

GLOSSARY OF TERMS (CONTINUED)

Retention/Detention Facility – A type of drainage facility designed either to hold water for a considerable length of time and then release it by evaporation, plant transpiration, and/or infiltration into the ground, or to hold surface and storm water runoff for a short period of time and then release it to the surface and storm water management system.

Rill erosion – An erosion process in which numerous small channels only several inches deep are formed; occurs mainly on recently disturbed and exposed soils. See Rill.

Riparian Rights – A principle of common law which requires that any user of waters adjoining or flowing through his lands must so use and protect them that he will enable his neighbor to utilize the same waters undiminished in quantity and undefiled in quality.

Riparian – Pertaining to banks of streams, wetlands, lakes, or tide waters.

Riser – The inlet portions of a drop inlet spillway that extends vertically from the pipe conduit barrel to the water surface.

Runoff – That portion of precipitation that flows from a drainage area on the land surface, in open channels or in storm water conveyance systems.

Salmonid – A member of the fish family salmonidae. Includes Chinook, coho, chum, sockeye and pink salmon, cutthroat, steelhead, rainbow, Dolly varden, brook, kokanee, and whitefish.

Sand – (1) Soil particles between 0.05 and 2.0 mm in diameter. (2) A soil textural class inclusive of all soils which are at least 70% sand and 15% or less clay.

Saturation – In soils, the point at which a soil or an aquifer will no longer absorb any amount of water without losing an equal amount.

Scour – The clearing and digging action of flowing water, especially the downward erosion caused by stream water in sweeping away mud and silt from the stream bed and outside bank of a curved channel.

Sediment Delivery Ratio – The fraction of the soil eroded from upland sources that actually reaches a stream channel or storage reservoir.

Sediment Discharge – The quantity of sediment, measured in dry weight or by volume, transported through a stream cross-section in a given time. Sediment discharge consists of both suspended load and bedload.

Sediment Pool – The reservoir space allotted to the accumulation of sediment during the life of the structure.

Sediment – Fragmented material originated from weathering and erosion of rocks and unconsolidated deposits. The material is transported by, suspended in, or deposited by water.

Sedimentation – Deposition or formation of sediment.

GLOSSARY OF TERMS (CONTINUED)

Seedbed – The soil prepared by natural or artificial means to promote the germination of seed and the growth of seedlings.

Seedling – A young plant grown from seed.

Settling Basin – An enlargement in the channel of a stream to permit the settling of debris carried in suspension.

Sheet Erosion – Relatively uniform removal of soil from an area without the development of conspicuous water channels.

Sheet erosion – The gradual removal of a fairly uniform layer of soil from the land surface by runoff water.

Sheet Flow – Relatively uniform flow over a plane surface without concentration of water into conspicuous channels.

Silt – (1) Soil fraction consisting of particles between 0.002 and 0.05 mm in diameter. (2) A soil textural class indicating more than 80% silt.

Siltation – Process by which a river, lake or other water body becomes clogged with sediment. Siltation can clog gravel beds and prevent successful salmon spawning.

Slope – Degree of deviation of a surface from the horizontal; measured as a numerical ratio or percent. Expressed as a ratio, the first number is the horizontal distance (run) and the second is the vertical distance (rise), e.g., 2:1. Slope can also be expressed as the rise over the run. For instance, a 2:1 slope is a 50 percent slope.

Soil Horizon – A horizontal layer of soil that, through processes of soil formation, has developed characteristics distinct from the layers above and below.

Soil Profile – A vertical section of the soil from the surface through all horizons.

Soil Stabilization – Use of rock-lining, vegetation, or other methods to prevent soil movement when loads are applied to the soil.

Soil Structure – The relation of particles or groups of particles which impart to the whole soil a characteristic manner of breaking; some types are crumb structure, block structure, platy structure, and columnar structure.

Soil Texture – The physical structure or character of soil determined by the relative proportions of the soil separates (sand, silt, and clay) of which it is composed.

Soil – The unconsolidated mineral and organic material on the immediate surface of the earth that serves as a natural medium for the growth of land plants.

GLOSSARY OF TERMS (CONTINUED)

Spillway – A passage such as a paved apron or channel for surplus water over or around or through a dam or similar structure. An open or closed channel, or both, used to convey excess water from a reservoir. It may contain gates, whether manually or automatically controlled, to regulate the discharge of excess water.

Splash erosion – The spattering of small soil particles caused by the impact of raindrops on wet soils. The loosened and spattered particles may or may not be subsequently removed by surface runoff.

Storm Frequency – The statistical time interval between major storms of predetermined intensity and runoff volumes for which storm sewers and other structures are designed and constructed to handle hydraulically without surcharge or back flood.

Storm Sewer – A sewer that carries storm water, surface drainage, street wash and other wash waters, but excludes sewage and industrial wastes. Also called a storm drain.

Storm Water Facility – A constructed component of a storm water drainage system, designed or constructed to perform a particular function, or multiple functions. Storm water facilities include pipes, swales, ditches, culverts, street gutters, detention basins, retention basins, constructed wetlands and other.

Storm Water – That portion of precipitation that does not percolate into the ground or evaporate, but flows via overland flow, interflow, channels or pipes into a defined surface water channel, or a constructed infiltration facility.

Stream Gauging – The quantitative determination of stream flow using gauges, current meters, weirs, or other measure instruments at selected locations. See Gauging station.

Streambanks – The usual boundaries, not the flood boundaries, of a stream channel. Right and left banks are named facing downstream.

Subcritical Flow – Flow at relatively low velocity where the wave from a disturbance can move upstream. Froude No. less than 1.

Subsoil – The B horizons of soils with distinct profiles. In soils with weak profile development, the subsoil can be defined as the soil below which roots do not normally grow.

Subsurface Drain – A pervious backfilled trench usually containing stone and perforated pipe for intercepting groundwater or seepage.

Subwatershed – A watershed subdivision of unspecified size that forms a convenient natural unit.

Surface Runoff – Precipitation that falls onto the surfaces of roofs, streets, the ground, etc., and is not absorbed or retained by that surface, but collects and runs off.

Suspended Solids – Organic or inorganic particles suspended in and carried by water: sand, mud, clay as well as solids.

GLOSSARY OF TERMS (CONTINUED)

Swale – An elongated depression in the land surface that is at least seasonally wet, is usually heavily vegetated, and is normally without flowing water. Swales conduct storm water into primary drainage channels and may provide some groundwater recharge.

Tile Drainage – Land drainage by means of a series of tile lines laid at a specified depth, grade and spacing.

Tile – Drainpipe made of perforated plastic, burned clay, concrete, or similar material, laid to a designed grade and depth, to collect and carry excess water from the soil.

Time of Concentration – The time period necessary for surface water runoff to reach the outlet of a sub-basin from the hydraulically most remote point in the tributary drainage area.

Toe of Slope – The base or bottom of a slope at the point where the ground surface abruptly changes to a significantly flatter grade.

Topography – General term to include characteristics of the ground surface such as plains, hills, mountains, degree of relief, steepness of slopes and other physiographic features.

Topsoil – The dark-colored surface layer of A horizon of a soil. When present it ranges in depth from a fraction of an inch to 2 or 3 feet; equivalent to the plow layer of cultivated soils. Commonly used to refer to the surface soil layer(s), enriched in organic matter and having textural and structural characteristics favorable for plant growth.

Total Solids – Solids in water, sewage or other liquids including dissolved, filterable and nonfilterable solids. The residue left when moisture evaporates and the remainder is dried at a specified temperature.

Total Suspended Solids (TSS) – The entire amount of organic and inorganic particles dispersed in water. TSS are the larger particles in the water which are more easily removed by sedimentation than smaller particles which cause turbidity.

Toxicity – The characteristic of being poisonous or harmful to plant animal life; the relative degree or severity of this characteristic.

Transmissivity – The volumetric flow rate per unit thickness under laminar flow conditions, in the in-plane direction of the fabric.

Trash Rack – structural device used to prevent debris from entering a pipe spillway or other hydraulic structure.

Turbidity – Is caused by silt and clay particles, particles smaller than 0.02 mm, suspended in water. Measurement of turbidity can be done by turbidimeter which measures light-beam scatter caused by small suspended particles and converts it to NTU (national turbidity units).

Turf – Surface soil supporting a dense growth of grass and associated root mat.

GLOSSARY OF TERMS (CONTINUED)

Unified Soil Classification – A classification system based on the identification of soils System according to their particle size, gradation, plasticity index, and liquid limit.

Vactor Waste – The waste material in the bottom of a catch basin.

Vegetative Stabilization – Protection of erodible or sediment-producing areas with:

1. Permanent seeding, producing long-term vegetative cover,
2. Short-term seeding, producing temporary vegetative cover, or
3. Sodding, producing areas covered with a turf of perennial sod-forming grass.

Water Quality – A term used to describe the chemical, physical, and biological characteristics of water, usually in respect to its suitability for a particular purpose.

Water Resources – The supply of groundwater and surface water in a given area.

Water Table – The free surface of the groundwater. That surface subject to atmospheric pressure under the ground, generally rising and falling with the season, or from other conditions such as water withdrawal.

Watercourse – A definite channel with bed and banks within which concentrated water flows, either continuously or intermittently.

Watershed Area – All land and water within the confines of a drainage divide.

Weir – Device for measure or regulating the flow of water. Weir notch the opening in a weir for the passage of water.

Wet Pond – A facility treating storm water by utilizing a permanent pool of water to remove conventional pollutants from runoff. Treatment mechanisms include sedimentation, biological uptake and plant filtration.

Wet Season – October 1 to April 3