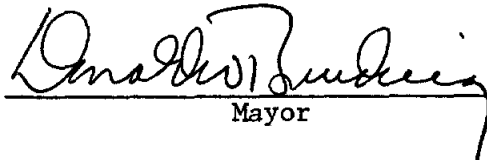

RESOLUTION NO. 2357

NOW, THEREFORE, BE IT RESOLVED by the Albany Council that the following be accepted by the City of Albany:

<u>Grantor</u>	<u>Purpose</u>
Victor G. Lands, M.D.	Easement for maintenance of sidewalk along Waverly Drive and 14th Avenue (see attached legals for Easement "D", "E", "F").
Victor G. Lands, M.D.	Maintenance Agreement for on-site pump station and storm drain facilities (see attached Exhibits "A" and "B").
Victor G. Lands, M.D.	Memorandum of Agreement for storm drainage maintenance for property referred to in attached Exhibit "A".

DATED this 13th day of October, 1982.

  
\_\_\_\_\_  
Mayor

ATTEST

  
\_\_\_\_\_  
City Recorder

SEP 23 1982

**DEVCO**  
ENGINEERING  
INC

CIVIL STRUCTURAL SURVEYING CONSTRUCTION MANAGEMENT

September 22, 1982

Mr. Stephen Bryant  
City of Albany  
127 Broadalbin S.W.  
Albany, Oregon 97321

Dear Mr. Bryant:

Subject: Albany Plaza

Enclosed, please find the following agreements executed by Dr. Lands:

1. Easement for Maintenance of Sidewalk. This easement supplies the additional 5 foot sidewalk along Waverly Drive.
2. Memorandum of Agreement. This agreement will provide the City with assurance that the maintenance on the pump station and storm drain facilities will be properly attended.
3. Memorandum of Agreement. This agreement is to be recorded in the County Deed Records.

After the City of Albany has provided the necessary signatures, please return a copy of these agreements to our office for our files.

If you have any questions, please feel free to contact this office at your convenience.

Sincerely,

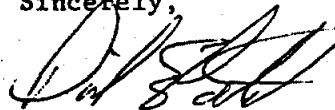

David E. Potter  
Civil Engineer

Encl.

EASEMENT  
FOR  
MAINTENANCE OF SIDEWALK

THIS AGREEMENT, made and entered into this 14<sup>th</sup> day of October, 1982, by and between VICTOR G. LANDS, M.D. herein called "Grantors", and the CITY OF ALBANY, a Municipal Corporation, herein called "City".

WITNESSETH, that for and in consideration of the sum of no dollars which do convey and transfer unto the City of Albany, a permanent easement and right-of-way, including the perpetual right to enter upon the real property hereinafter described at any time that it may see fit, and to construct, maintain and repair sidewalk for the purpose of constructing a sidewalk over, across, through and under the lands hereinafter described, together with the right to excavate and refill ditches and/or trenches for the location of the said sidewalk and the further right to remove trees, bushes, undergrowth and other obstructions interfering with the location, construction and maintenance of the said sidewalk.

The easement and right-of-way hereby granted covers a strip of land of variable width for the purpose of maintenance over the following described property:

SEE ATTACHED

TO HAVE AND TO HOLD the said easement and right-of-way unto the City of Albany and unto its successors and assigns forever.

EASEMENT "D", "E", "F"

LEGAL DESCRIPTION FOR ALBANY PLAZA PUBLIC ACCESS EASEMENT

LOCATED IN THE CITY OF ALBANY, OREGON

SIDEWALK ALONG WAVERLY DRIVE & 14TH AVENUE

EASEMENT D

Beginning at a point on the west boundary of the Donation Land Claim of Anderson Cox Claim No. 49, Township 11 South, Range 3 West of the Willamette Meridian, Linn County, State of Oregon, said point being South  $1^{\circ}22'$  East 200.00 feet distant from a point on the west line of said claim, 93.04 chains northerly from the southwest corner of said Claim No. 49, said last point being the point of intersection of the west line of said claim with the center line of the Santiam Highway, from said beginning point running thence South  $70^{\circ}22'58''$  East 32.13 feet, 32.15 feet per C.S. 17803; thence South  $70^{\circ}22'58''$  East 10.71 feet to the TRUE POINT OF BEGINNING; thence South  $70^{\circ}22'58''$  East 5.36 feet; thence South  $01^{\circ}22'00''$  East 273.15 feet; thence South  $88^{\circ}38'00''$  West 5.00 feet; thence North  $01^{\circ}22'00''$  West 275.07 feet to the TRUE POINT OF BEGINNING.

EASEMENT E

Beginning at a point on the west boundary of the Donation Land Claim of Anderson Cox Claim No. 49, Township 11 South, Range 3 West of the Willamette Meridian, Linn County, State of Oregon, said point being South 1°22' East 200.00 feet distant from a point on the west line of said claim, 93.04 chains northerly from the southwest corner of said Claim No. 49, said last point being the point of intersection of the west line of said claim with the center line of the Santiam Highway, from said beginning point running thence South 70°22'58" East 32.13 feet, 32.15 feet per C.S. 17803; thence South 01°22'00" East 501.20 feet; thence North 88°38'00" East 10.00 feet to the TRUE POINT OF BEGINNING; thence North 88°38'00" East 5.00 feet; thence South 01°22'00" West 170.76 feet; thence North 70°17'00" West 5.36 feet; thence North 01°22'00" West 168.84 feet to the TRUE POINT OF BEGINNING.

EASEMENT F

Beginning at a point on the west boundary of the Donation Land Claim of Anderson Cox Claim No. 49, Township 11 South, Range 3 West of the Willamette Meridian, Linn County, State of Oregon, said point being South 1°22' East 200.00 feet distant from a point on the west line of said claim, 93.04 chains northerly from the southwest corner of said Claim No. 49, said last point being the point of intersection of the west line of said claim with the center line of the Santiam Highway, from said beginning point running thence South 70°22'58" East 32.13 feet, 32.15 feet per C.S. 17803; thence South 01°22'00" East 746.22 feet; thence South 70°17'00" East 10.72 feet to the TRUE POINT OF BEGINNING; thence South 70°17'00" East 5.36 feet; thence South 01°22'00" East 278.52 feet; thence South 88°38'00" West 5.00 feet; thence North 01°22'00" West 280.09 feet to the TRUE POINT OF BEGINNING.

The City covenants that should it become necessary subsequent to the original construction of the said sidewalk, to enter in and upon the property for the purpose of maintenance, that the property will be restored to that condition that it was prior to the undertaking of the maintenance.

The Grantors do hereby covenant with the City that they are lawfully seized and possessed of the real property above described and that they have a good and lawful right to convey it or any part thereof and that they will forever warrant and defend the title thereto against the lawful claims of all person whomsoever.

IN WITNESS WHEREOF, the grantors have hereunto fixed their hands and seals the day and year first above written.

Victor G. Lands, M.D.

STATE OF OREGON )  
County of Linn ) ss  
City of Albany )

On this 21 day of September, 1982, personally appeared the above named Victor G. Lands, M.D. and acknowledged the foregoing instrument to be his voluntary act and deed.

Subscribed and sworn to before me this 21 day of September 1982.

Ellen Winchberger  
Notary Public for Oregon  
My Commission Expires: 1-12-86

STATE OF OREGON )  
County of Linn ) ss  
City of Albany )

I, Donald W. Brudvig, as Mayor of the City of Albany, Oregon, pursuant to Resolution Number 2357, do hereby accept on behalf of the City of Albany, the above easement pursuant to the terms thereof.

Dated: October 14, 1982.

CITY OF ALBANY, OREGON

Donald W. Brudvig  
Mayor

[Signature]  
Recorder

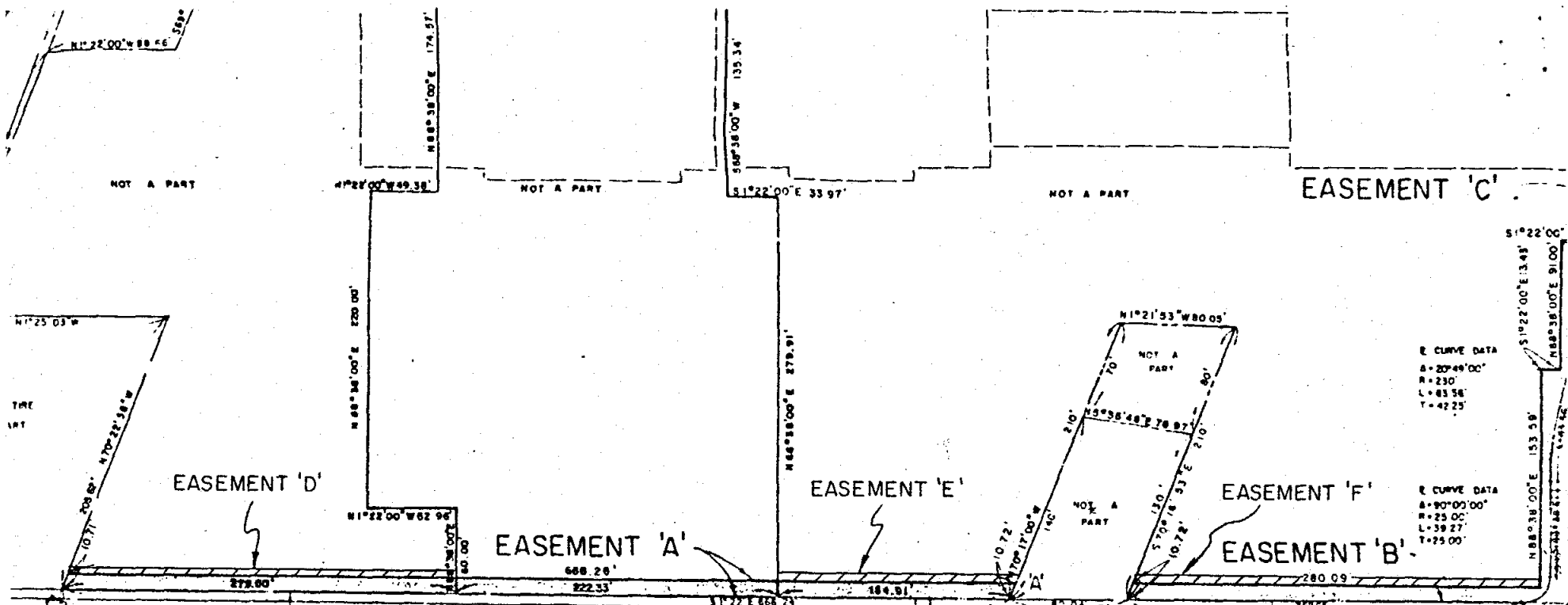

E CURVE DATA  
 A = 20°44'00"  
 R = 230'  
 L = 83.56'  
 T = 42.25'

E CURVE DATA  
 A = 90°00'00"  
 R = 25.00'  
 L = 39.27'  
 T = 25.00'

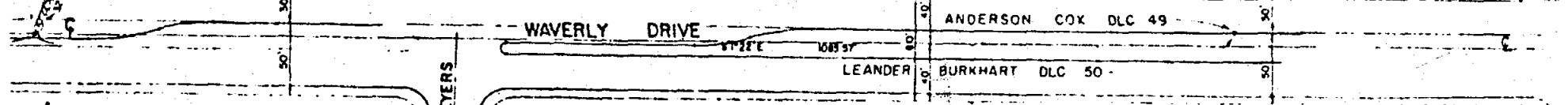

**PUBLIC ACCESS EASEMENT (SIDEWALK PURPOSES)**

ON A PARCEL OF LAND LOCATED IN THE  
 NORTHEAST QUARTER SEC. 8, T. 11 S., R. 3 W., W.B. & M.  
 LINN COUNTY, OREGON

MAINTENANCE AGREEMENT

THIS AGREEMENT is made and entered into this 14<sup>th</sup> day of October, 1982, by and between VICTOR G. LANDS M.D., Owner and Developer of the Albany Plaza Shopping Center, hereinafter referred to as OWNER; and the CITY OF ALBANY, a municipal corporation of the City of Albany, hereinafter referred to as the CITY.

WHEREAS, the CITY has granted certain zone change and conditional use permit approvals to the Owner allowing the construction of a shopping center in the CITY, and

WHEREAS, the site plan for said shopping center provides for storm water detention facilities for the purpose of storing storm water until the down stream storm drainage system can adequately dispose of runoff from the shopping center, and

WHEREAS, the CITY and the OWNER desire to set out the understanding of the parties as to their respective responsibilities for the maintenance of said storm water detention facilities,

NOW, THEREFORE, THE PARTIES MUTUALLY AGREE AS FOLLOWS:

The storm water detention facilities in question are intended to benefit property of the OWNER situated in the CITY OF ALBANY, Linn County, Oregon, and more particularly described as follow:

LEGAL DESCRIPTION: (See Exhibit "A" attached)



The detention pump facilities shall be constructed in accordance with the specifications set forth in Exhibit "B" attached hereto and by this reference incorporated herein.

All maintenance of the storm water detention facilities shall be the responsibility of the OWNER. The various components and functions of the storm water detention facilities are as follows:

1. A 36"dia.-1535 feet concrete pipe will be used to provide below ground storage of storm waters.
2. A duplex 25 HP Hydronix Pump Station will be used to elevate the storm water from the 36"dia. pipe thru a 12" PVC pressure pipe to a catch basin located at the southeast corner of 14th Street and Waverly Drive.
3. The storm water system has been designed for a 10-year design storm frequency. The discharge from the pump station into the catch basin at 14th Street and Waverly Drive is calculated to be 6.23 cfs. (2800 gpm).
4. It has been calculated that there will be no surcharging of the storm waters into the public parking areas associated with Albany Plaza Project. A maximum surcharge depth of approximately 0.5 feet is anticipated in the employee parking area (detention basin area) based on a 10-year storm frequency interval. A maximum surcharge depth of approximately 1.2 feet is anticipated in the employee parking area in addition to a surcharge depth of 0.4 feet in the truck wells based on a 50-year storm frequency interval.

Normal maintenance shall include the following:

1. Caring for the ground cover and any other landscaping (irrigation, trimming, mowing, etc.).
2. Removal of debris from the storm drainage system.

3. Checking and maintaining the pump station facilities to determine that the facilities are in working order as specified in the various functions and specifications.

Storm maintenance shall include the following:

1. Removal of debris from the catch basins, the storm drainage piping system, and the pump station facilities.
2. Repair of landscaping around pump station facilities.

The CITY, its agents, representatives and employees, shall at all times have access to the storm water detention facilities and related components.

Should the OWNER fail to maintain the detention basin in accordance with the specifications set forth above and in Exhibit "B", the CITY may make such repairs as may be necessary to restore the storm detention facilities to said condition, or contract with third parties for such restoration and the OWNER shall pay any and all such costs incurred.

Prior to initiating said repairs, the CITY shall give the OWNER 30 days notice in writing of the necessary repairs and shall undertake such repairs itself only in the event that the OWNER fails to effect said repairs within 30 days of the sending of said notice. Notwithstanding the foregoing, should an emergency arise, the CITY shall be entitled to effect all necessary repairs and bill the costs thereof to the OWNER as set forth above. An emergency shall be defined as any condition wherein the storm water detention facilities are not functioning according to the specifications set forth in Exhibit "B" at such time as storm waters are present and failure to make the necessary repair is likely to exceed the capacity of existing storm drainage facilities such that flooding of surrounding properties is imminent.

Notice shall be deemed received by the OWNER upon deposit of written notice in the United States Post Office with postage prepaid, addressed

to the OWNER at 811 Strada Vecchia Road Los Angeles, California 90077.

Should the OWNER fail to pay said costs within 30 days of submission of the bill, the CITY shall be entitled to a lien against the property of the OWNER to secure payment.

The CITY's remedies for breach of this agreement by the OWNER are cumulative and those remedies set forth herein shall be in addition to any and all other remedies available at law or in equity.

This agreement shall indure to the benefit of the CITY, its successors and assigns, and shall be binding upon the OWNER together with their heirs, successors and interest, and assigns, and shall at all times remain an obligation of the OWNER or OWNER's of Exhibit "A".

DATED this 14<sup>th</sup> day of October, 1982.

CITY OF ALBANY:

By Victor G. Lands, M.D.

OWNER: VICTOR G. LANDS, M.D.

By Willie Barron

STATE OF OREGON )  
 ) ss.  
County of Linn )

On this 21 day of September, 1982, personally appeared the above named Victor G. Lands, M.D. and acknowledged the foregoing to be his voluntary act and deed.

Before me:

Ellen Winckler  
NOTARY PUBLIC FOR OREGON  
My Commission Expires: 1-12-86

STATE OF OREGON

)  
) ss.

County of )

On this 14<sup>th</sup> day of October, 1982, personally appeared the above named William B. Barrons and acknowledged the foregoing to be his voluntary act and deed.

Before me:

Dorelene B. Whitney  
NOTARY PUBLIC FOR OREGON  
My Commission Expires: 12-14-83



EXHIBIT "A"

LEGAL DESCRIPTION  
FOR  
ALBANY PLAZA SHOPPING CENTER

Parcel I.

Beginning at a point on the west boundary of the Donation Land Claim of Anderson Cox, Claim No. 49, Township 11 South, Range 3 West of the Willamette Meridian, Linn County, State of Oregon, said point being South 1°22' East 200.00 feet distance from a point on the west line of said claim, 93.04 chains northerly from the southwest corner of said Claim No. 49, said last point being the point of intersection of the west line of said claim with the center line of the Santiam Highway, from said beginning point running thence South 70°22'58" East 32.13 feet (32.15 feet per C.S. 17803) to the TRUE POINT OF BEGINNING; thence South 70°22'58" East 205.62 feet (205.50 feet per C.S. 17803); thence North 1°25'03" West 157.86 feet; thence South 70°13'04" East 56.02 feet; thence South 70°10'00" East 143.98 feet; thence South 1°22'00" East 88.66 feet; thence South 69°36'30" East 87.62 feet; thence North 72°23'40" East 61.12 feet; thence North 1°22'00" West 50.00 feet; thence South 70°10'00" East 50.00 feet; thence South 1°22'00" East 423.97 feet; thence North 70°17'36" West 68.54 feet; thence South 1°25'29" East 722.87 feet; thence North 70°33'00" West 358.39 feet; thence along a 230.00 foot curve 83.56 feet (long chord bearing North 80°57'30" West, 83.10 feet); thence South 88°38'00" West 59.95 feet; thence along 25.00 foot curve 39.27 feet (long chord bearing North 46°22'00" West, 35.36 feet); thence North 1°22'00" West 268.95 feet; thence South 70°16'53" East 210.00 feet (South 70°17'00" East, 209.95 feet per C.S. 17803); thence North 1°21'53" West 80.05 feet (North 1°24'27" West 80.00 feet per C.S. 17803); thence North 70°17'00" West 210.00 feet; thence North 1°22'00" West 666.24 feet to the TRUE POINT OF BEGINNING.

Parcel II

Beginning at an iron rod which is South 1°22' East along the west line of the Anderson Cox Donation Land Claim No. 49 in Township 11 South, Range 3 West of the Willamette Meridian, Linn County, Oregon, 466.82 feet and South 70°17' East, parallel to the South Santiam Highway 568.76 feet from the intersection of the west line of said Donation Land Claim No. 49 and the center line of said Santiam Highway, said intersection being 93.04 chains North of the southwest corner of said Donation Land Claim No. 49 to the TRUE POINT OF BEGINNING and running thence South 70°17'36" East 68.54 feet; thence South 70°17' East, parallel to said Santiam Highway, 49.46 feet; thence South 1°22'00" East, parallel to the west line of said Donation Land Claim No. 49, a distance of 319.32 feet; thence North 70°17' West, parallel to said highway 118.00 feet; thence North 1°25'29" West 319.36 feet to the TRUE POINT OF BEGINNING.

## EXHIBIT B

### SPECIFICATIONS FOR THE PREFABRICATED WET WELL MOUNTED VACUUM-PRIMING PUMPING STATION

#### INTRODUCTION

The Contractor shall furnish and install one factory-built wet well mounted pumping station with all necessary parts and equipment that will provide for a complete working station.

#### OPERATING CONDITIONS

Each of the Dewatering Pumps shall be capable of delivering a capacity of 1400 GPM of raw sewage against a Total Dynamic Head of 46 feet, including a Suction Lift of 15 feet. The rated horsepower of each pump motor shall be 25 HP. All openings and passages shall be large enough to permit the passage of a 3" diameter solid, or stringy material which can pass through a 4" house collection system.

#### PUMP CHAMBER

The pumping machinery, controls, and auxiliary equipment as described below shall be mounted on a 3/16" thick, formed steel base. The base shall be reinforced as required to support the pumps, motors and suction piping. A 1/4" thick steel arch shall be welded to the base to provide hinge points for the Fiberglass hoods and to support the Control Panel. The entire base and arch assembly shall be hot dipped galvanized.

Two 1/4" thick polyester fiberglass hoods shall be provided to cover the pumping station. The hoods shall be hinged to the aforementioned arch to provide maximum accessibility to the pumping machinery, controls, and auxiliary equipment when they are open. In addition, a means shall be provided to assure the station is weather-tight when the hoods are closed. A means for locking the station shall be provided.

#### PUMPS

The pumps shall be vertical dry pit close coupled non-clog type, capable of passing a 3" sphere. The pump case shall be of high grade heavy cast iron with large clean out ports located in the casing near cutwater. The impeller shall be of cast iron, two-vane, non-clog, enclosed type, secured to the tapered shaft with a positive key. Double mechanical shaft seal with oil-filled seal chamber.

#### MOTORS

Motors shall be the vertical close coupled drip-proof, squirrel-cage induction type with low starting current and normal starting torque characteristics. The motors shall be non-overloading at the designed operating point and shall not exceed the service factor rating at the minimum specified head. (1750 RPM, 3 PHASE, 460 VOLT.)

### PRIMING

The priming shall be completely Duplex using separate vacuum chamber, pump, drains and controls for each pump.

### CONTROLS

Controls shall be by the lift station manufacturer, and shall be NEMA 1 design mounted inside the lift station, with circuit breakers, magnetic motor starters with 3rd leg overload protection, indication lights and H.O.A. selector switches. All terminals shall be numbered. An electric alternator shall also be provided to change the sequence of operation on the completion of each pump cycle. Provisions also provided for the pumps to operate in parallel if the level in the wet well continues to rise above the "Start Lead Pump" level.

### WIRING

Wiring outside the control cabinet shall be run in "seal-flex conduit. Accessories where furnished by the manufacturer with approved flexible cord may be plugged into polarized receptacles. All wiring and electrical material shall be according to National Electrical Code requirements. It shall be the responsibility of the contractor to furnish and install correctly sized service wires from the service pole to the control cabinet. No splices shall be permitted in the service wires. It shall also be the responsibility of the contractor to furnish and install all required exterior disconnects, switching mechanisms, alarm or control conduit, wiring and meter base.

### PIPING

Suction pipes shall be 6" hot dipped galvanized, extending through the station floor and ending below the pump chamber floor with 6" galvanized threaded couplings. The contractor shall provide two (2) 6" galvanized suction pipes threaded by plain one end, extending to within 6" above the bottom of the wet well. Discharge piping shall be connected to a common 12" discharge line as shown in Detail A.

### HEATER

A 500 Watt electric space heater shall be furnished and installed: The heater shall be supplied with a three-wire flexible cord with polarized plug for single phase, 60 Hertz, 115 Volt power. The heater shall be provided with an adjustable thermostat

### EQUIPMENT MANUFACTURE

The pump station shall be equal to the factory fabricated plant Hydro-Matic Model 281-V 6" x 8" manufactured by HYDRONIX, INC. Portland, Oregon or be approved as equal.

To be considered an approved equal, complete details, shop drawings, pump curves, wiring diagrams and a list of prior installations must be submitted to the engineer. Sufficient data must be submitted so the engineer can determine if the alternate pump station meets the required specifications.

#### WARRANTY

The manufacturer of the sewage pumping station shall warrant for one year from date of shipment that the pumping station and all related equipment will be free from defects in material and factory workmanship.

Warranties and guarantees by the suppliers of various components of the pumping station in lieu of a single source responsibility by the pumping station manufacturer will not be accepted. The pumping station manufacturer shall be solely responsible for the warranty of the pumping station and all related components.

In the event a component fails to perform as specified or is proven defective in service during the warranty period, excluding items of supply normally expended during operation, the manufacturer shall provide a replacement part without cost to the owner.

This warranty shall be void only if the product is properly serviced and operated under normal conditions and in accordance with the manufacturer's instructions.

#### WET WELL CONSTRUCTION

The bedding rock shall be clean compacted 12 inch depth 1"-0 crushed rock uniformly graded. The concrete for the wet well base and formed in place pump station base shall not be less than 3000 psi at 28 days.

The precast wet well section shall be 72 inches in diameter conforming to ASTM C-478. The wet well shall have a flat precast 6 inch top slab designed for H-20 loading. The holes necessary for accepting the pump station shall be provided for in the wet well cover. Only keylock joints are acceptable and may be grouted together with nonshrink mortar.

Wet well frames and covers shall be cast iron conforming to ASTM A-48. All covers shall be true and shall seat within the frame at all points. All frames and covers shall be free from porosity, shrinkage cavities or other defects that would impair serviceability. Frames shall be of the suburban type and be tamper proof.



# MANHOLE FRAME & COVER

## MANHOLE

### FRAME AND COVER

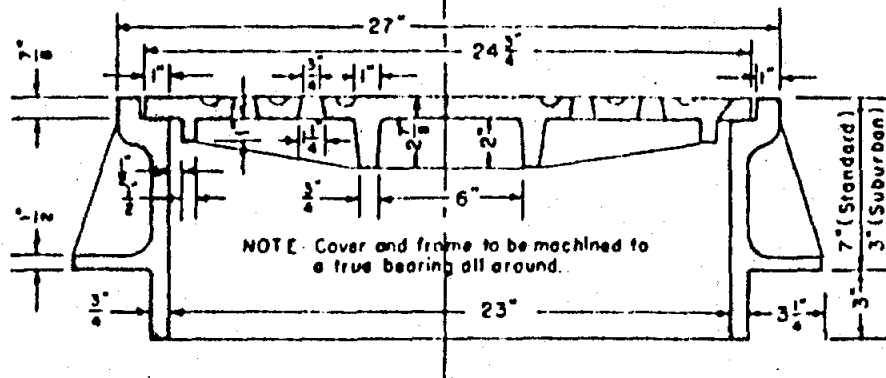
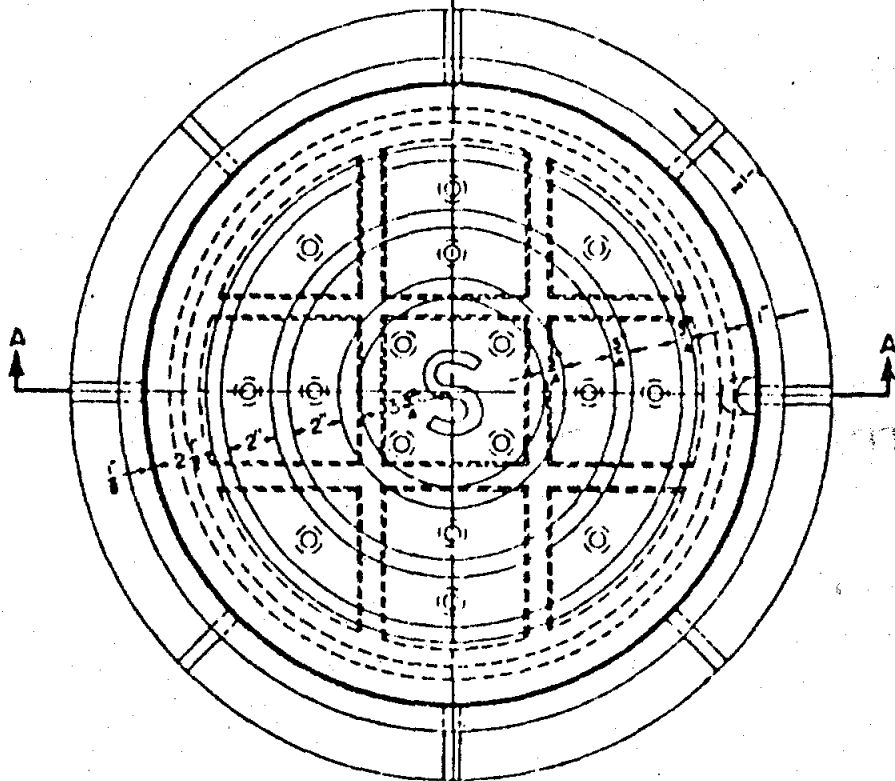

SECTION A-A

1500 A 2

MAY 1976

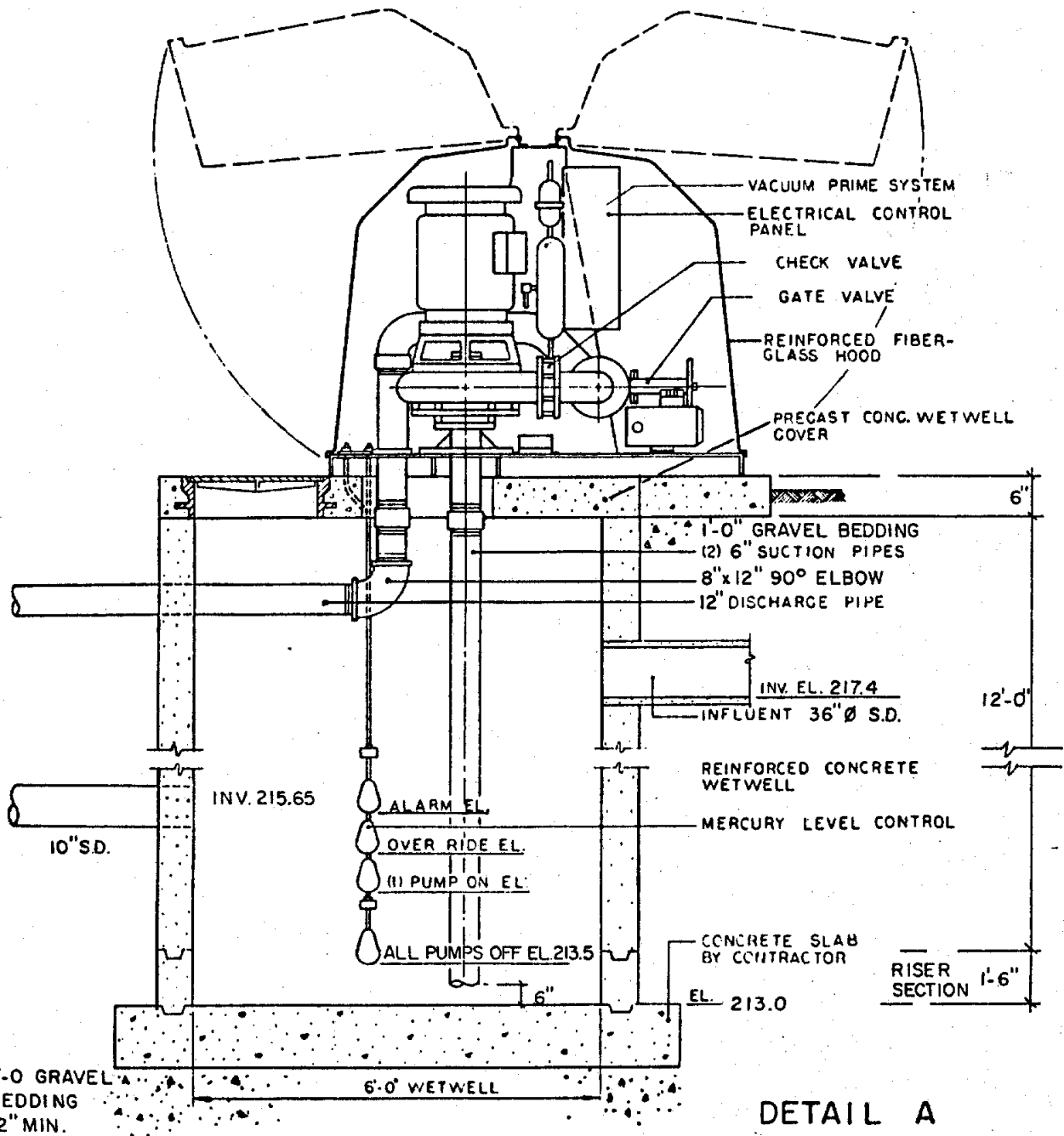
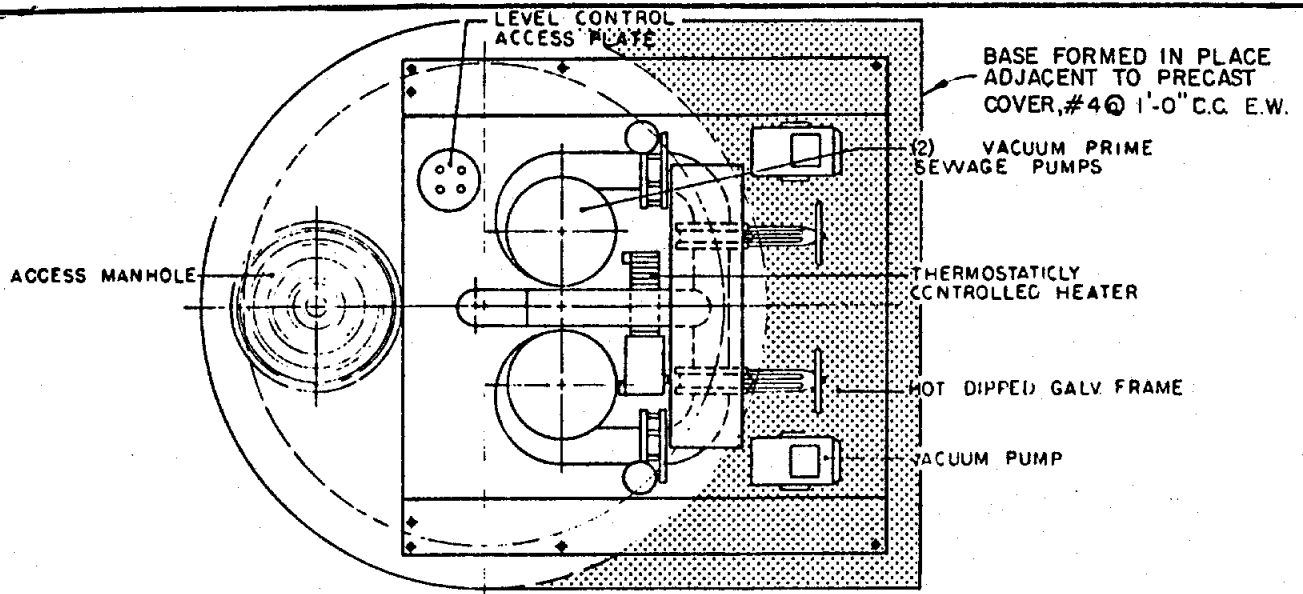

MEMORANDUM OF AGREEMENT

This Memorandum of Agreement shall reflect a Storm Drainage Maintenance Agreement entered into by and between Victor G. Lands, M.D., and the City of Albany on ~~September~~ <sup>October</sup> 14, 1982, such Agreement concerning certain conditions and restrictions on the property, which Agreement consists of

5 pages plus exhibits. Such Storm Drainage Maintenance Agreement concerns the property described in Exhibit "A" attached hereto.

Victor G. Lands, M.D.  
Victor G. Lands, M.D.

William B. Barrons  
William B. Barrons, City Manager  
City of Albany

STATE OF OREGON            )  
  ) ss.  
County of Linn             )

September 21, 1982

Personally appeared the above-named Victor G. Lands, M.D. and acknowledged the foregoing instrument to be his voluntary act. Before me:

Ellen Stinchberger  
NOTARY PUBLIC FOR OREGON  
My Commission expires: 1-12-86

STATE OF OREGON            )  
  ) ss.  
County of Linn             )

October 14, 1982

Personally appeared the above-named William B. Barrons and acknowledged the foregoing instrument to be his voluntary act. Before me:

Dorlene Whitney  
NOTARY PUBLIC FOR OREGON  
My Commission expires: 12-14-83

EXHIBIT "A"

LEGAL DESCRIPTION  
FOR  
ALBANY PLAZA SHOPPING CENTER

Parcel I

Beginning at a point on the west boundary of the Donation Land Claim of Anderson Cox, Claim No. 49, Township 11 South, Range 3 West of the Willamette Meridian, Linn County, State of Oregon, said point being South 1°22' East 200.00 feet distance from a point on the west line of said claim, 93.04 chains northerly from the southwest corner of said Claim No. 49, said last point being the point of intersection of the west line of said claim with the center line of the Santiam Highway, from said beginning point running thence South 70°22'58" East 32.13 feet (32.15 feet per C.S. 17803) to the TRUE POINT OF BEGINNING; thence South 70°22'58" East 205.62 feet (205.50 feet per C.S. 17803); thence North 1°25'03" West 157.86 feet; thence South 70°13'04" East 56.02 feet; thence South 70°10'00" East 143.98 feet; thence South 1°22'00" East 88.66 feet; thence South 69°36'30" East 87.62 feet; thence North 72°23'40" East 61.12 feet; thence North 1°22'00" West 50.00 feet; thence South 70°10'00" East 50.00 feet; thence South 1°22'00" East 423.97 feet; thence North 70°17'36" West 68.54 feet; thence South 1°25'29" East 722.87 feet; thence North 70°33'00" West 358.39 feet; thence along a 230.00 foot curve 83.56 feet (long chord bearing North 80°57'30" West, 83.10 feet); thence South 88°38'00" West 59.95 feet; thence along 25.00 foot curve 39.27 feet (long chord bearing North 46°22'00" West, 35.36 feet); thence North 1°22'00" West 268.95 feet; thence South 70°16'53" East 210.00 feet (South 70°17'00" East, 209.95 feet per C.S. 17803); thence North 1°21'53" West 80.05 feet (North 1°24'27" West 80.00 feet per C.S. 17803); thence North 70°17'00" West 210.00 feet; thence North 1°22'00" West 666.24 feet to the TRUE POINT OF BEGINNING.

Parcel II

Beginning at an iron rod which is South 1°22' East along the west line of the Anderson Cox Donation Land Claim No. 49 in Township 11 South, Range 3 West of the Willamette Meridian, Linn County, Oregon, 466.82 feet and South 70°17' East, parallel to the South Santiam Highway 568.76 feet from the intersection of the west line of said Donation Land Claim No. 49 and the center line of said Santiam Highway, said intersection being 93.04 chains North of the southwest corner of said Donation Land Claim No. 49 to the TRUE POINT OF BEGINNING and running thence South 70°17'36" East 68.54 feet; thence South 70°17' East, parallel to said Santiam Highway, 49.46 feet; thence South 1°22'00" East, parallel to the west line of said Donation Land Claim No. 49, a distance of 319.32 feet; thence North 70°17' West, parallel to said highway 118.00 feet; thence North 1°25'29" West 319.36 feet to the TRUE POINT OF BEGINNING.