



COMMUNITY DEVELOPMENT

333 Broadalbin Street SW, PO Box 490, Albany, Oregon 97321-0144 | COMMUNITY DEVELOPMENT 541-917-7550

Staff Report

Historic Review of Exterior Alterations and Substitute Materials

HI-18-24

September 25, 2024

Summary

This staff report evaluates a Historic Review of Substitute Materials and Exterior Alterations for a commercial structure on a developed lot within the Downtown National Register Historic District (Attachment A). The applicant proposes to modifications to exterior lighting, the removal of a rear stairway, changes to doors, the addition of mechanical units, and ADA improvements, with the use of substitute materials for the replacement of exterior windows.

Application Information

Review Body:	Landmarks Commission (Type III review)
Staff Report Prepared By:	Alyssa Schrems, Planner II
Property Owner/Applicant:	Glorietta Bay LLC/ Scott Lepman
Applicant's Representative:	Laura LaRoque, Udell Engineering & Land Surveying
Address/Location:	240 2nd Avenue SW, Albany, OR 97321
Map/Tax Lot:	Linn County Tax Assessor's Map No. 11S-03W-06CC-10200
Zoning:	Historic Downtown (HD) District (Downtown National Register Historic District)
Total Land Area:	14,023 square feet
Existing Land Use:	Commercial Business
Neighborhood:	Central Albany
Surrounding Zoning:	North: HD East: HD South: HD West: HD
Surrounding Uses:	North: Commercial, Store East: Commercial, Restaurants South: Commercial, Offices and Store West: Commercial, Restaurants
Prior History:	HI-03-07 – Application for Historic Review of Exterior Alterations to close off exterior restroom entrance with compatible materials. HI-16-07 – Application for Historic Review of Exterior Alterations to keep the taller of the two installed steel communications towers on top of the old Post Office building, extend the height to 70 feet and allow additional “whip” antennas up to 10 feet tall on top. HI-08-22 - Application for Historic Review of Exterior Alterations and Use of Substitute Materials for a commercial structure. The applicant proposes to remove and replace the existing membrane roof covering, complete

maintenance on the roof, remove and replace portions of the façade, remove the existing fire escape, restore existing wood windows, replace any windows beyond repair, replace the windows and door frames in the vestibule, modify the rear ramp to meet modern building code, and complete seismic upgrades.

Notice Information

On September 11, 2024, a notice of public hearing was mailed to property owners within 100 feet of the subject property. On September 20, 2024, notice of public hearing was also posted on the subject site. As of September 24, 2024, one comment has been received in support of the application. The comment was from a neighboring property owner, Oscar Hult, who expressed support for the proposed alterations and supports the use of substitute materials which appear to be removable in the future.

Analysis of Development Code Criteria

Historic Review of Exterior Alterations Generally (ADC 7.120)

Albany Development Code (ADC) review criteria for Historic Review of Exterior Alterations Generally (ADC 7.120) are addressed in this report for the proposed development. The criteria must be satisfied to grant approval for this application. Code criteria are written in **bold** followed by findings, conclusions, and conditions of approval where conditions are necessary to meet the review criteria.

Exterior Alteration Criteria (ADC 7.100-7.165)

Section 7.150 of the ADC, Article 7, establishes the following review criteria in **bold** for Historic Review of Exterior Alterations applications. For applications other than the use of substitute materials, the review body must find that one of the following criteria has been met in order to approve an alteration request.

- 1. The proposed alteration will cause the structure to more closely approximate the historical character, appearance, or material composition of the original structure than the existing structure; OR**
- 2. The proposed alteration is compatible with the historic characteristics of the area and with the existing structure in massing, size, scale, materials, and architectural features.**

Findings of Fact

- 1.1** Location and Historic Character of the Area. The subject property is located at 240 2nd Avenue SW in the Historic Downtown (HD) zoning district within the Downtown National Register Historic District. The surrounding properties are in the HD zoning district and are developed with a mix of uses including commercial, restaurants, offices, and parking lots.
- 1.2** Historic Rating. The subject building is rated as a Historic Contributing resource in the Downtown National Register Historic District. The building was constructed in 1914.
- 1.3** History and Architectural Style. The nomination form lists the architectural style of the building as Federal style. The structure was first constructed as the post office and was eventually turned into City Hall for the city. The building is sometimes referred to as “old City Hall” or “Federal Building”.
- 1.4** Proposed Exterior Alterations. The applicant proposes to install new exterior lighting as detailed in the submittals, install replacement windows using Anderson A-Series Fibrex windows (except for storefront windows which will be aluminum), remove exterior doors on the rear and sides of the main building and infill, remove a wood door on the rear of the building and replace with a full-lite metal door, remove metal stairways and railing on the south side of the addition, add mechanical units on the roof of the rear addition, and remove and replace ADA ramps, with the installation of a new steel frame, metal roofed doorway canopy. Proposed use of substitute materials (windows) is discussed further in ADC 7.170-7.225.

ADC 7.150 further provides the review body will use the Secretary of the Interior’s Standards for Rehabilitation as guidelines in determining whether the proposed alteration meets the review criteria. Conclusions for ADC 7.150 and 7.160 will be discussed below.

Secretary of Interior’s Standards for Rehabilitation – (ADC 7.160)

The following standards are to be applied to rehabilitation projects in a reasonable manner, taking into consideration economic and technical feasibility.

1. A property shall be used for its historic purpose or be placed in a new use that requires minimal change to the defining characteristics of the building and its site and environment.
2. The historic character of a property shall be retained and preserved. The removal of historic material or alteration of features and spaces that characterize a property shall be avoided.
3. Each property shall be recognized as a physical record of its time, place, and use. Changes that create a false sense of historical development, such as adding conjectural features or architectural elements from other buildings, shall not be undertaken.
4. Most properties change over time; those changes that have acquired historic significance in their own right shall be retained and preserved.
5. Distinctive features, finishes, and construction techniques or examples of craftsmanship that characterize a historic property shall be preserved.
6. Deteriorated historic features shall be repaired rather than replaced. Where the severity of deterioration requires replacement of a distinctive feature, the new feature shall match the old in design, color, texture, and other visual qualities and, where possible, materials. Replacement of missing features shall be substantiated by documentary, physical, or pictorial evidence.
7. Chemical or physical treatments, such as sandblasting, that cause damage to historic material shall not be used. The surface cleaning of structures, if appropriate, shall be undertaken using the gentlest means possible.
8. Significant archeological resources affected by a project shall be protected and preserved. If such resources must be disturbed, mitigation measures shall be undertaken.
9. New additions, exterior alterations, or related new construction shall not destroy historic materials that characterize the property. The new work shall be differentiated from the old and shall be compatible with the massing, size, scale, and architectural features to protect the historic integrity of the property and its environment.
10. New additions and adjacent or related new construction shall be undertaken in such a manner that if removed in the future, the essential form and integrity of the historic property and its environment would be unimpaired.

Findings of Fact

- 2.1 Building Use (ADC 7.160(1)). The building was originally constructed as a United States Post Office but was sold in 1965 to the City of Albany and was converted into City Hall. In 1995 the city sold the building, and it was converted into commercial use. The current property owner proposes to use the property as a boutique hotel or “commercial retail sales and service-oriented” use. Based on these facts, this criterion is met.
- 2.2 Historic Character (ADC 7.160(2)). The structure was constructed in the Federal style. In the 1960s several alterations to the structure occurred, including the rear addition and the exterior aluminum vestibule. These changes have not acquired a historic significance in their own right. Based on these facts, criterion ADC 7.160(2) is met.
- 2.3 Historic Record & Changes (ADC 7.160(3) and (4)). The structure was originally constructed in 1914 in the Federal style. The applicant does not propose any conjectural features or architectural elements from other buildings. Changes to the structure included the rear addition, aluminum vestibule, and ADA ramps have not acquired historic significance in their own right. Based on these facts, criterion ADC 7.160(3 and 4) are met.
- 2.4 Distinctive characteristics (ADC 7.160(5)). The structure was originally constructed in 1914 in the Federal style. Distinctive features include windows that have a stone architrave with bead and reel molding, and plain frieze, a cornice with leaf and dart enrichment in the ogee molding, dentil course, columns and pilasters with acanthus details and abacus, entablature with leaf and dart architrave molding, four arched openings on the north side, and a corner stone on the NW corner at 2nd and Broadalbin. The ground floor windows are double hung, six over six, with a wood sash. The second-floor windows are double hung, six over six with a “Union Jack” design, with a wood sash. The

applicant states that distinctive features, finishes, and construction techniques or examples of craftsmanship that characterize the property shall be preserved.

- 2.5 Deteriorated Features (ADC 7.160(6)). The applicant proposes to restore the building façade to approximate the original design and finish details as shown in historic photos. The applicant states that the proposal will restore some of the missing architectural elements and craftsmanship of the building based on pictorial evidence. Based on these facts, criterion ADC 7.160(6) is met.
- 2.6 Use of Chemical or Physical Treatments (ADC 7.160(7)). The applicant states they will not use chemical or physical treatments. Based on this, the criterion is met.
- 2.7 Significant Archaeological Resources (ADC 7.160(8)). The applicant states there are no known archeological resources located at or near this site. If significant archeological resources are found on the site, the contractor will notify the architect who will notify a SHPO archeologist. The artifact will not be moved and work in the area will cease until SHPO is done with their review. Based on these facts, this criterion appears to be met.
- 2.8 Historic Materials (ADC 7.160(9)). The applicant states the exterior alterations will not destroy historic materials that characterize the property. The proposed alterations will approximate the size, scale, and architectural features based on pictorial evidence. The Commission may determine if this criterion is met based on further evidence and testimony submitted.
- 2.9 New Additions (ADC 7.160(10)). The applicant states that there are no new additions proposed with this request, therefore this criterion is not applicable.

Conclusions

- 2.1 The proposed exterior alterations will restore deteriorated and/or missing character-defining features on the front façade.
- 2.2 The proposed alterations will cause the structure to approximate the original historic character and appearance of the building, potentially satisfying ADC 7.150(1) and consistent with the Secretary of Interior's Standards in ADC 7.160,

Historic Review of the Use of Substitute Materials (ADC 7.170-7.225)

ADC eligibility for the use of substitute materials (ADC 7.200(1)) and review criteria for Historic Review of the Use of Substitute Materials (ADC 7.200) are addressed in this report for the proposed development. The criteria must be satisfied to grant approval for this application. Code criteria are written in **bold** followed by findings, conclusions, and conditions of approval where conditions are necessary to meet the review criteria.

Eligibility for the Use of Substitute Materials (ADC 7.200)

The City of Albany interprets the Secretary of Interior's Standards for Rehabilitation on compatibility to allow substitute siding and windows only under the following conditions:

The building or structure is rated historic non-contributing; OR

In the case of historic contributing buildings or structures, the existing siding, windows or trim is so deteriorated or damaged that it cannot be repaired and finding materials that would match the original siding, windows or trim is cost prohibitive.

Any application for the use of substitute siding, windows, and/or trim will be decided on a case-by-case basis. The prior existence of substitute siding and/or trim on the historic buildings on the Local Historic Inventory will not be considered a factor in determining any application for further use of said materials.

The applicant proposes to replace wood windows with Andersen A-Series Fibrex exterior and wood interior windows. According to the applicant, Fibrex is a PVC-wood composite material.

Findings of Fact

- 3.1 Eligibility and Existing Conditions. The subject building is rated as a Historic Contributing resource in the Downtown National Register Historic District. The applicant states that the basement window openings consist of nine infilled window openings along with five rotten wood frames/sashes and two metal bar inserts. On the rear southern elevation there is one rotten wood frame and sashes. The

applicant also discusses the conditions of the aluminum vestibule windows but asserts that they are exempt from review as they are a like for like replacement. No photographic evidence of the damaged nature of the frames and sashes were provided. The applicant states that the cost of replacement material and long-term maintenance of the material would be cost prohibitive for the project. The applicant shall have the opportunity to expand on their eligibility for substitute materials at the hearing.

- 3.2 Substitute Materials. The applicant proposes to replace the windows with Andersen A-Series Fibrex exterior and wood interior windows, except for the vestibule windows which will be replaced with aluminum framed and glazed windows.

Conclusions

- 3.1 The building is rated as a Historic Contributing resource in the Downtown National Historic District and is therefore not eligible for review under the first threshold in ADC 7.200.
- 3.2 The applicant states that wood elements that are damaged due to rot will be replaced with Andersen A-Series Fibrex exterior and wood interior windows.
- 3.3 Based on the above analysis, staff recommends additional information regarding the cost prohibitive nature of non-substitute materials and additional evidence of the damaged nature of the wood frames and sashes. The applicant shall have an opportunity to expand on their eligibility at the hearing.

Design and Application Criteria for the Use of Substitute Materials (ADC 7.210)

Criterion 1

The proposed substitute materials must approximate in placement, profile, size, proportion, and general appearance of the existing siding, windows or trim.

Findings of Fact

- 1.1 The applicant states that detailed architectural drawings are enclosed with the application and depict placement, profile, size, proportion, and general appearance of existing and proposed materials. The Commission may determine the suitability of the proposed design, placement, profile, size and general appearance.

Conclusions

- 1.1 New windows are proposed to match the general appearance of the existing windows.
- 1.2 The Commission may determine if this criterion is met.

Criterion 2

Substitute siding, windows and trim must be installed in a manner that maximizes the ability of a future property owner to remove the substitute materials and restore the structure to its original condition using traditional materials.

Findings of Fact and Conclusions

- 2.1 The applicant states that all installed materials can be removed and replaced later if needed without considerable damage to the structure.
- 2.2 This criterion has been satisfied.

Criterion 3

The proposed material must be finished in a color appropriate to the age and style of the house, and the character of both the streetscape and the overall district. The proposed siding or trim must not be grained to resemble wood.

Findings of Fact

- 3.1 The applicant states that none of the window components will be grained to resemble wood.

Conclusions

- 3.1 The proposed material may not be wood grained.
- 3.2 This criterion has been satisfied.

Criterion 4

The proposed siding, windows or trim must not damage, destroy, or otherwise affect decorative or character-defining features of the building. Unusual examples of historic siding, windows and/or trim may not be covered or replaced with substitute materials.

Findings of Fact and Conclusions

- 4.1 The applicant states that the substitute windows and frames will not be installed over, or cover unusual examples of historic windows, trim, or decorative and character-defining features of the building.
- 4.2 Based on these facts, the criterion appears to be satisfied.

Criterion 5

The covering of existing historic wood window or door trim with substitute trim will not be allowed if the historic trim can be reasonably repaired. Repairs may be made with fiberglass or epoxy materials to bring the surface to the original profile, which can then be finished, like the original material.

Findings of Fact and Conclusions

- 5.1 There does not appear to be any historic wood trim on the structure.
- 5.2 Based on these facts, this criterion is satisfied.

Criterion 6

Substitute siding or trim may not be applied over historic brick, stone, stucco, or other masonry surfaces.

Findings of Fact

- 6.1 The applicant does not propose to install any siding or trim.

Conclusions

- 6.1 There is no siding or trim to be installed over the historic limestone or stucco.

Summary – Substitute Materials

The applicant proposes to replace wood windows with Andersen A-Series Fibrex exterior and wood interior windows. According to the applicant, Fibrex is a PVC-wood composite material.

Overall Conclusions

The applicant proposes to install new exterior lighting as detailed in the submittals, install replacement windows using Anderson A-Series Fibrex windows (except for storefront windows which will be aluminum), remove exterior doors on the rear and sides of the main building and infill, remove a wood door on the rear of the building and replace with a full-lite metal door, remove metal stairways and railing on the south side of the addition, add mechanical units on the roof of the rear addition, and remove and replace ADA ramps, with the installation of a new steel frame, metal roofed doorway canopy.

Staff finds all applicable criteria are met for the exterior alterations and use of substitute materials but encourages additional information regarding eligibility be provided by the applicant at the hearing.

Options and Recommendations

The Landmarks Commission has five options with respect to the subject application:

- Option 1: Approve the requests as proposed;
- Option 2: Approve the requests with conditions of approval;
- Option 3: Approve the Exterior Alteration request but deny the Use of Substitute Materials;
- Option 4: Approve the Use of Substitute Materials but deny the Exterior Alteration; or
- Option 5: Deny the requests.

Based on the discussion above, staff recommends the Landmarks Commission pursue Option 2 and approve both the Exterior Alteration request and the Use of Substitute Materials request with conditions. If the Landmarks Commission accepts this recommendation, the following motion is suggested.

Motion

I move to approve the exterior alterations and use of substitute materials including conditions of approval as noted in the staff report for application planning file no. HI-18-24. This motion is based on the findings and conclusions in the September 25, 2024 staff report and findings in support of the application made by the Landmarks Commission during deliberations on this matter.

Conditions of Approval

- Condition 1 **Exterior Alterations** – The proposed exterior alterations shall be performed and completed as specified in the staff report. Deviations from these descriptions may require additional review.
- Condition 2 **Historic Review** – A final historic inspection is required to verify that the work has been done according to this application. Please call the historic planner (541-791-0176) a day or two in advance to schedule.
- Condition 3 **Use of Substitute Materials** – Only the windows discussed in the application may be replaced. If additional windows are found to need replacement a new review shall be required.
- Condition 4 **Use of Substitute Materials** - The windows to be replaced shall be replaced with Andersen A-Series Fibrex windows. If a different type of substitute window is proposed it will require a new review.

Attachments

- A. Location Map
- B. Historic Resource Survey
- C. Land Use Findings
- D. Site Plan & Drawings

Acronyms

- ADC Albany Development Code
- HD Historic Downtown District

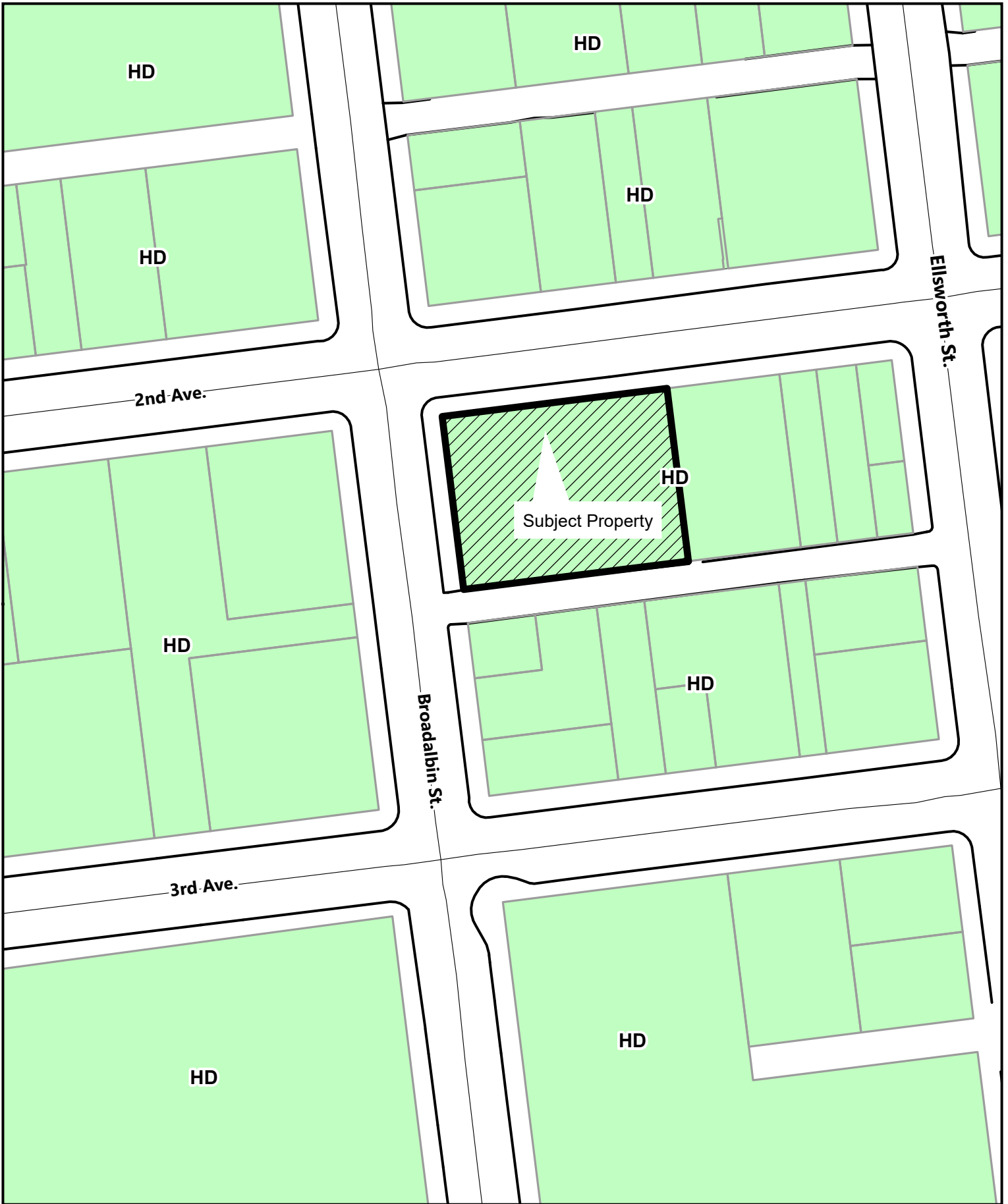

\\con.cityofalbany.net\homes\analysis\Desktop\Notice Map Template.mxd



240 2ND AVE SW

Date: 9/10/2024 Map Source: City of Albany

Location Map

OREGON INVENTORY OF HISTORIC PROPERTIES
HISTORIC RESOURCE SURVEY - ALBANY
DOWNTOWN HISTORIC DISTRICT

Attachment B.1

COUNTY: Linn

HISTORIC NAME: Old Post Office

ORIGINAL USE: Post Office/Federal

COMMON NAME: City Hall

CURRENT USE: Office/Retail

ADDRESS: 240 2nd Ave SW

CONDITION: Fair

ADDITIONAL ADDRESS

INTEGRITY: Good **MOVED?**

CITY: Albany

DATE OF CONSTRUCTION: c. 1914

OWNER: Lund, Robert A.

THEME: Federal

CATAGORY: Building

STYLE: American Renaissance

LOCATION: Downtown Historic District

ARCHITECT: James Knox Taylor

MAP NO: 11S 3W 6CC

TAX LOT: 10200

BUILDER:

BLOCK: 7

LOT: 1

QUADRANGLE: Albany

ADDITION NAME:

LOCAL RANKING: Primary

PIN NO: 11S03W06CC10200

ZONING: HD

SPECIAL ASSESSMENT: Y **YR:** 1994

PLAN TYPE/SHAPE: Rectangle

NO. OF STORIES: 2

FOUNDATION MAT.: Brick

BASEMENT: Y

ROOF FORM/MAT.: Shallow Hipped Roof

PORCH: N

STRUCTURAL FRAMING: Brick/Concrete

PRIMARY WINDOW TYPE: Ground floor, double hung wood sash, 6 light over 6. 2nd story: paired w. "Union Jack" design.

EXTERIOR SURFACING MATERIALS: Stucco over brick

DECORATIVE FEATURES:

Windows have stone architrave w/ bead and reel molding, plain freize. Cornice w/ leaf and dart enrichment in the ogee molding. Dentil course. Column and pilasters have acanthus details and abacus.

Entablature w/ leaf and dart architrave molding. Four arched openings on north side, corner stone on the NW corner at 2nd & Broadalbin.

EXTERIOR ALTERATIONS/ADDITIONS:

Aluminum entry doors. Concrete additions at the rear (south). Basement windows filled in.

NOTEWORTHY LANDSCAPE FEATURES:

6 trees and some shrubs on 2nd Ave. 2 trees on Broadalbin.

ADDITIONAL INFO:

Two city bus shelters on the west side (Broadalbin).

INTERIOR FEATURES:

Now divided into offices on 2nd floor and basement. Retail on 1st floor.



OREGON INVENTORY OF HISTORIC PROPERTIES
HISTORIC RESOURCE SURVEY - ALBANY
HISTORIC DISTRICT

Attachment B.2

COUNTY: Linn

NAME: Lund, Robert A.
ADDRESS: 240 2nd Ave SW
QUADRANGLE Albany

PIN 11S03W06CC10200
MAP 11S03W06CC
TAX LOT: 10200

SQ FT: 80x55

G/P SOURCES: Planning Division/L. Schwab

EID FOOTPRINT: N/A

OTHER INFO:

ADA ACCESS (Y/N): N

PARKING (Y/N): Y PARKING SPACES: 4

ELEVATOR (Y/N): N

PARAPET (Y/N): Y

SEISMIC (Y/N): N

HISTORIC PHOTO: Y

NEGATIVE NO.: C25

SLIDE NO.: 15C

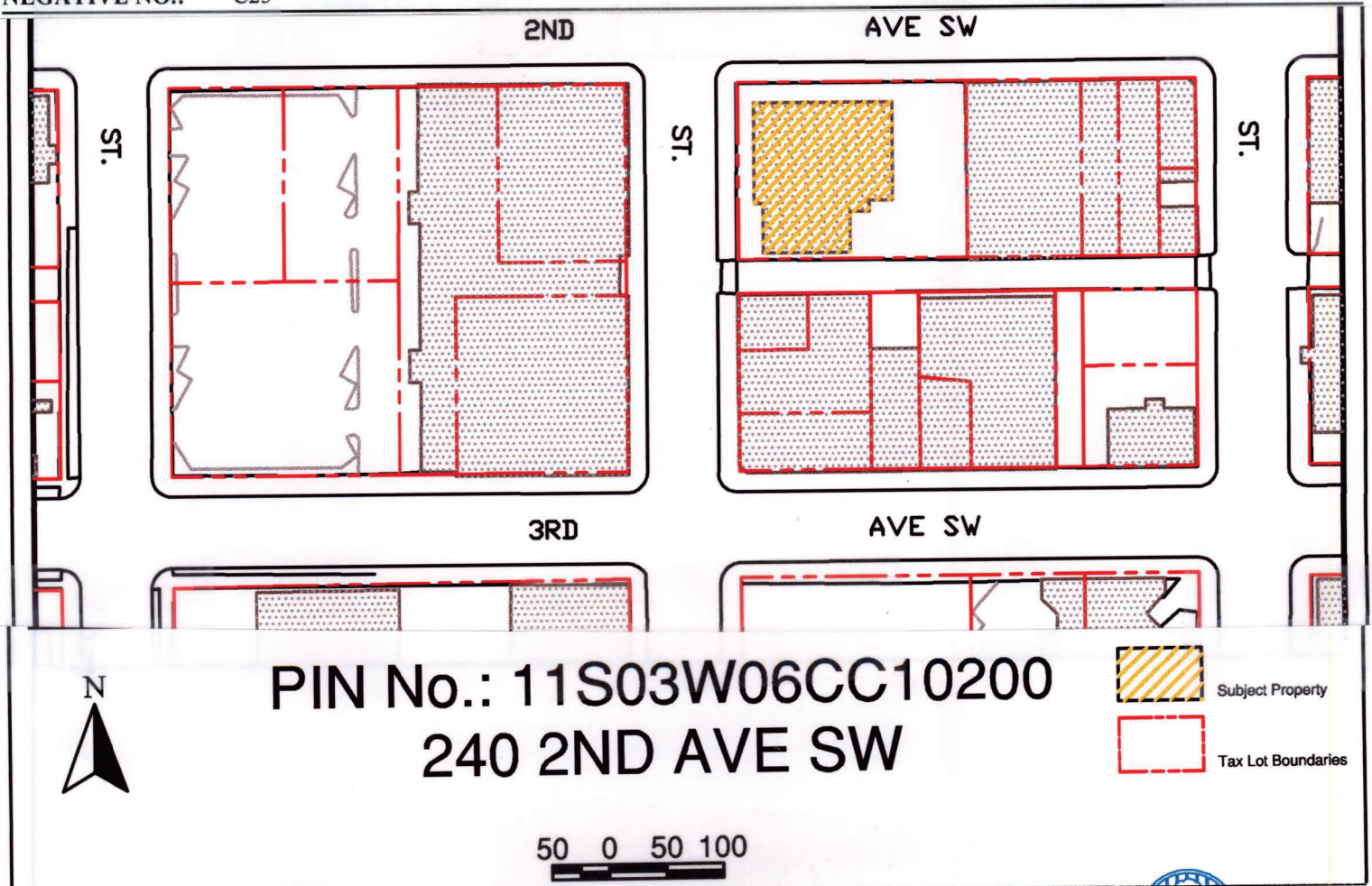

RECORDED BY: Roz Keeney

DATE: 3/99

LOCAL INVENTORY NO.: 51

SHPO INVENTORY NO.: None

CASE FILE NUMBER: HI-12-93, HI-08-87, HI-08-88, HI-17-89

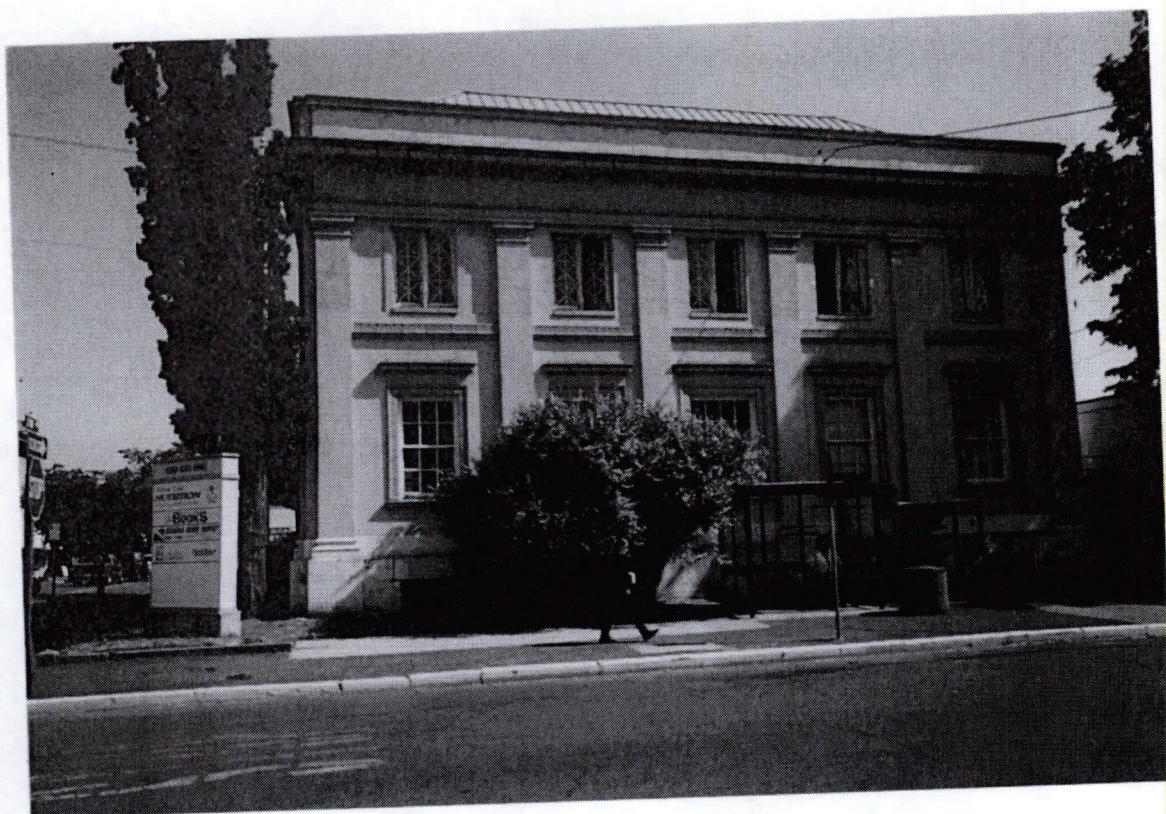
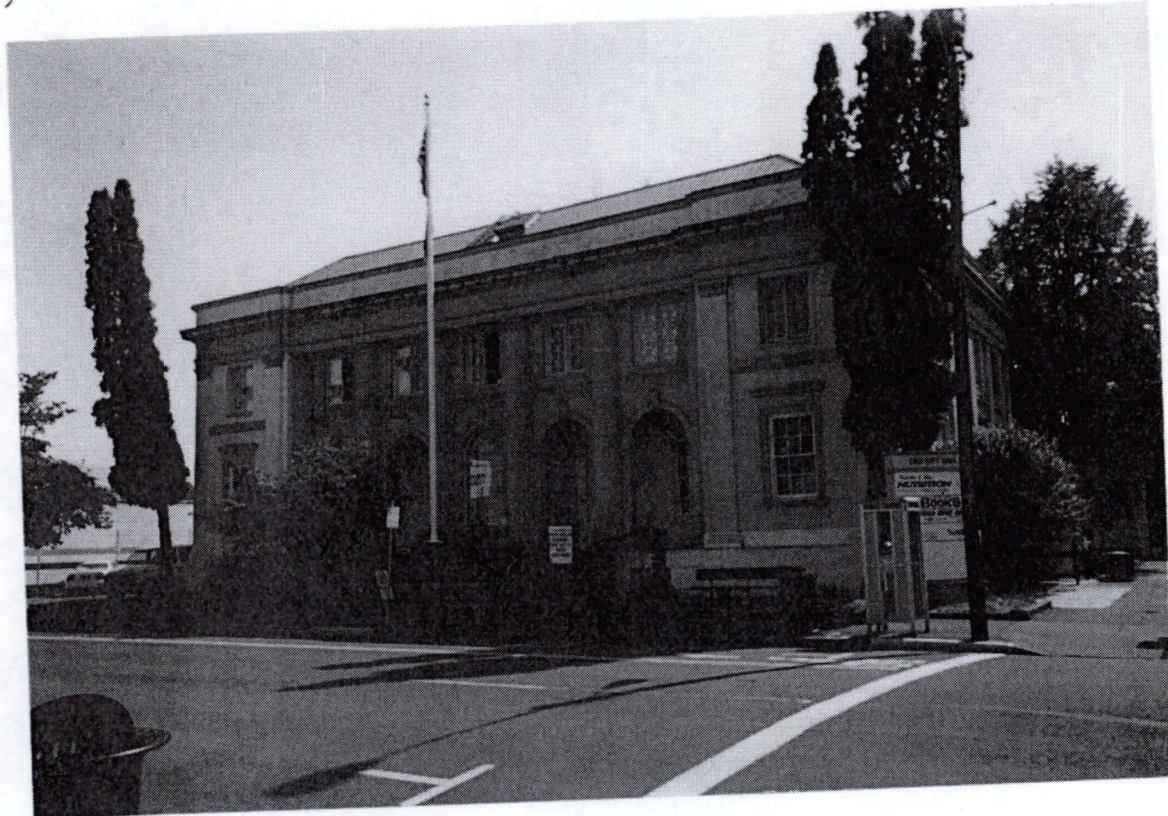





Historic Review of Exterior Alterations & Use of Substitute Materials

Submitted to: City of Albany
Planning Division
P.O. Box 490
Albany, Oregon 97321-0144
(541) 917-7550
cd.customerservice@cityofalbany.net

Property Owner/Applicant: Glorietta Bay LLC
100 Ferry Street NW
Albany, OR 97321
Scott Lepman
(541) 928-9390
scottlepman@gmail.com

Applicant's Representative: Udell Engineering and Land Surveying, LLC
63 E. Ash Street
Lebanon, OR 97355
Laura LaRoque
(541) 990-8661
laura@udelleng.com

Applicant's Representative: Varitone Architecture, LLC
231 2nd Ave. SW
Albany, OR 97321
Christina Larson
(541) 497-2954
christina@varitonearchitecture.com

Site Location: 240 2nd Avenue SW, Albany, OR 97322

Linn County Assessor's Map No.: 11S-03W-06CC Tax Lot 10200

Site Size: ±14,023 square feet

Existing Land Use: Commercial Structure

Zone Designation: Historic Downtown (HD) Zoning District

Comprehensive Plan Designation: Village Center

Surrounding Zoning: North: HD
South: HD
East: HD
West: HD

Surrounding Uses: North: Commercial

South: Commercial
 East: Commercial
 West: Commercial

Prior History: HI-03-07: Application for Historic Review of Exterior Alterations to close off exterior restroom entrance with compatible materials.

HI-16-07: Application for Historic Review of Exterior Alterations to keep the taller of the two installed steel communications towers on top of the old Post Office building, extend the height to 70 feet and allow additional “whip” antennas up to 10 feet tall on top.

HI-08-22: Application for Historic Review of Exterior and Use of Substitute Materials to remove and replace the existing membrane roof covering, complete maintenance on the roof, remove and replace portions of the façade, remove the existing fire escape, restore existing wood windows, replace any windows beyond repair, replace the windows and door frames in the vestibule, modify the rear ramp to meet modern building code, and complete seismic upgrades.

Executive Summary

Applications for Historic Review of Exterior Alterations and the Use of Substitute Materials for the Federal Building/Old City Hall commercial building located at 240 2nd Avenue SW that is a historic resource listed in the Downtown National Register Historic District.

According to Albany Development Code (ADC) 1.100, Table 1.100-1, 7.120(2), and 7.180, a Type III Quasi-Judicial Review before the Landmarks Commission is required for requests for exterior alterations of commercial buildings and the use of substitute materials on historic resources listed on the National Register of Historic Places.

The applicant is completing an interior and exterior renovation of the structure for commercial bouquet hotel in accordance with Oregon's Special Assessment of Historic Property Program and Federal Historic Preservation Tax Incentives program. Exterior renovations not already a vested by a former land use approval and that are subject to historic review, include the following:

1. Exterior Lighting:
 - a. In-Grade Luminaire (“L-1” Light Style) - Installation of new in-ground lighting. No contact with building. Proposed lighting will accent all pilasters around the building perimeter. Not subject to historic review.
 - b. Lamp Post / Pole Light (“L-2” Light Style) - Installation of ground mounted lighting. No contact with building. Existing landscape planters will become concrete pads for pole light installation.
 - c. LED Accent Lighting (“L-3” Light Style) - Installation of flexible LED lighting affixed by small screws and contained in aluminum channeling along back side of cornice. Proposed lighting will accent top cornice.
 - d. Entry Downlighting (“L-4” Light Style) - Replacement of existing lighting downlighting with new downlighting.
 - e. Utility Lighting / Wall Sconce (“L-5” Light Style) - Replacement of existing wall mounted utility style lighting along the back steel fire escape and back sides of building.

2. Windows:
 - a. At-Grade / Basement Windows (“D” Window Type) – Remove all at-grade / basement windows opening infill. Remove at-grade / basement windows opening metal bars. Replace all at-grade / basement windows with new Andersen, A-Series Fibrex exterior and wood interior windows. Replace metal bars with new metal bars (see keynote 02-16 and 02-25).
 - b. Storefront Windows / Exterior Vestibule (“S1, S2, and S3” Window Type) - Remove existing windows and door frames of the exterior vestibule. Replaced with new aluminum to match existing, color clear anodized.
 - c. Rear Elevation of Main Building (“E” Window Type) – Remove one existing window, install new windows and infill upper portion parge coat to match existing. Replacement window to be an Andersen, A-Series Fibrex exterior and wood interior window type (see keynotes 02-06/02-20).
 - d. Rear Elevation of Main Building (“G” Window Type) - Remove existing infill block to expose original windows. Restore and reinstall original windows (see keynote 02-05).
 - e. Rear Addition (“H” Window Type) - Add five new windows opening and windows to rear building addition. New windows to be Andersen, A-Series Fibrex exterior and wood interior window type.
3. Exterior Doors:
 - a. Remove door on rear main building (second story) and infill to match (see keynotes 02-04/09-01)
 - b. Remove existing hollow metal door on south building addition and replace with new full-lite, metal door (see keynote 02-07).
 - c. Remove existing wood door on rear west main building elevation and replace with new full-lite, wood door (see keynote 02-11).
 - d. Remove door on east and west main building elevation. Infill openings with a 1-inch recess (see keynote 02-17).
4. Rear Stairway:
 - a. Removal of existing metal stairway and railing on south elevation of the addition.
5. Mechanical Units:
 - a. Addition of mechanical units on the rooftop of rear addition.
6. ADA Accessibility:
 - a. Remove existing ramp and railing. Install new concrete ramp and painted metal tube railing (see keynote 02-03).
 - b. Installation of new steel frame, metal roofed doorway canopy (see HR-08(03)(04))
 - c. Remove existing ADA ramp and railing on rear addition and replace with new ADA compliant ramp and railing.

The Historic Review of Exterior Alterations and the Use of Substitute Materials criteria contained in Albany Development Code (ADC) 7.150 and ADC 7.210 are addressed in this report. These criteria must be satisfied to grant approval for this application.

Historic Review of Exterior Alterations (ADC 7.100-7.165)

Section 7.150 of the Albany Development Code (ADC), Article 7, establishes the following review criteria in **bold** for Historic Review of Exterior Alterations applications. For applications other than for substitute materials, the review body must find that one of the following criteria has been met to approve an alteration request.

1. The proposed alteration will cause the structure to more closely approximate the historical character, appearance or material composition of the original structure than the existing structure; OR
2. The proposed alteration is compatible with the historic characteristics of the area and with the existing structure in massing, size, scale, materials, and architectural features.

ADC 7.150 further provides that the review body will use the Secretary of the Interior's Standards for Rehabilitation as guidelines in determining whether the proposed alteration meets the review criteria

Secretary of Interior's Standards for Rehabilitation – (ADC 7.160)

The following standards are to be applied to rehabilitation projects in a reasonable manner, taking into consideration economic and technical feasibility.

1. A property shall be used for its historic purpose or be placed in a new use that requires minimal change to the defining characteristics of the building and its site and environment.
2. The historic character of a property shall be retained and preserved. The removal of historic material or alteration of features and spaces that characterize a property shall be avoided.
3. Each property shall be recognized as a physical record of its time, place, and use. Changes that create a false sense of historical development, such as adding conjectural features or architectural elements from other buildings, shall not be undertaken.
4. Most properties change over time; those changes that have acquired historic significance, in their own right, shall be retained and preserved.
5. Distinctive features, finishes, and construction techniques or examples of craftsmanship that characterize a historic property shall be preserved.
6. Deteriorated historic features shall be repaired rather than replaced. Where the severity of deterioration requires replacement of a distinctive feature, the new feature shall match the old in design, color, texture, and other visual qualities and, where possible, materials. Replacement of missing features shall be substantiated by documentary, physical, or pictorial evidence.
7. Chemical or physical treatments, such as sandblasting, that cause damage to historic material shall not be used. The surface cleaning of structures, if appropriate, shall be undertaken using the gentlest means possible.
8. Significant archeological resources affected by a project shall be protected and preserved. If such resources must be disturbed, mitigation measures shall be undertaken.
9. New additions, exterior alterations, or related new construction shall not destroy historic materials that characterize the property. The new work shall be differentiated from the old and shall be compatible with the massing, size, scale, and architectural features to protect the historic integrity of the property and its environment.
10. New additions and adjacent, or related new construction shall be undertaken in such a manner that if removed in the future, the essential form and integrity of the historic property and its environment would be unimpaired.

The analysis includes findings related to the Exterior Alterations review criteria in ADC 7.150, followed by the evaluation of the applicable Secretary of Interior Standards in ADC 7.160.

Findings of Fact

- 1.1 Location and Historic Character of the Area. The subject property, known as the “Old City Hall” or “Federal Building,” is located at 240 2nd Avenue SW in the Historic Downtown (HD) zoning district within the Downtown National Register Historic District. The surrounding properties are in the HD zoning district and are developed with a mix of uses including commercial, mixed-uses, and parking lots.
- 1.2 Historical Rating. The subject building is rated as a Historic Contributing resource in the Downtown National Register Historic District.
- 1.3 History and Architectural Style. The nomination form has a circa 1914 date and lists the building as the Federal Building and Post Office constructed in the limestone and stucco facing, Federal architectural style.
- 1.4 Prior Alterations. Exterior alterations listed in the nomination form include exterior vestibule, one-story rear addition, and infilled basement window openings.
- 1.5 Proposed Exterior Alterations. The applicant is completing an interior and exterior renovation of the structure for commercial bouquet hotel in accordance with Oregon's Special Assessment of Historic Property Program and Federal Historic Preservation Tax Incentives program. Exterior renovations not already vested by a former land use approval and that are subject to historic review, are listed in the executive summary and incorporated herein by reference.
- 1.6 Building Use (ADC 7.160(1)). The building’s original use was a United States Post Office. In 1965, the City of Albany purchased the building and converted it into a City Hall. In 1995, ownership and use of the building changed to commercial retail stores and offices. In 2015, the building was acquired by the current owner, and its use remains commercial.
The proposed use is a bouquet hotel or “commercial retail sales and service-oriented” use per the Albany Development Code. Interior and exterior alterations are proposed in association with the proposed use which are consistent with ADC 7.160(1).
- 1.7 Historic Record and Building Changes (ADC 7.160(3) and (4)). No conjectural features or architectural elements from other styles, buildings or time periods are proposed. In 1960, an adjoining building was torn down which exposed the east brick wall. A stucco coating was applied to this façade at that time. The property was further altered in the mid-60s. Alterations included a rear (south, one-story addition) for public restrooms and the existing exterior aluminum vestibule. These changes have not acquired historic significance. The proposal is consistent with ADC 7.160(3) and (4).
- 1.8 Distinctive Features and Character (ADC 7.160(2), (5), and (6)). The structure is a two-story building constructed in Federal architectural style. Decorative features noted in the nomination include limestone and stucco facing, shallow hipped roof, single bay pavilion framed with two-story pilasters, columns and pilasters support a full entablature, in modified Doric order. The applicant proposes to restore the entire building facade to approximate the original design and finish details as shown in historic photographs. The proposal will restore some of the missing architectural elements and craftsmanship of the building based on pictorial evidence satisfying ADC 7.160(2), (5), and (6).

- 1.9 Guidelines ADC 7.160(7) and (8) are not applicable. No chemical or physical treatments or soil disturbance of note is proposed. There are no known archaeological resources on the site.
- 1.10 Compatibility of Exterior Alterations and Additions (ADC 7.160(9) and (10)). The exterior alterations will not destroy historic materials that characterize the property. The proposed alterations will approximate the size, scale, and architectural features based on pictorial evidence consistent with ADC 7.160(9). No new additions are proposed with this request; therefore ADC 7.160(10) is not applicable.

Conclusions

- 1.1 The proposed exterior alterations will restore deteriorated and/or missing character-defining features on the street façades.
- 1.2 The proposed alterations will cause the structure to approximate the original historic character and appearance of the building satisfying ADC 7.150(1) and are consistent with the Secretary of Interior's Standards in ADC 7.160.
- 1.3 The proposal, as submitted, satisfies the review criteria for exterior alterations as proposed.

Historic Review of the Use of Substitute Materials Used for Siding, Windows, and Trim (ADC 7.170-7.225)

ADC 7.170 states that, "purpose of reviewing the use of substitute materials is to encourage the preservation of characteristics and materials of the historic architectural style. Review is required for the application of substitute materials for siding, windows and trim on buildings or structures originally constructed before 1946 and on the Local Historic Inventory."

ADC 7.020 defines a substitute material as, "materials made from different sources than the original materials. For example: If wood were the original material for siding, window or trim, material other than wood would be a substitute material." (Examples of substitute materials are plastic; vinyl; aluminum, and concrete.)

The application includes a proposal to replace and add new Andersen, A-Series Fibrex exterior and wood interior window types for windows denoted in the executive summary (incorporated herein by reference). Fibrex is a PVC-wood composite material.

The application also includes a proposal to replace an exterior vestibule which consists of a silver aluminum frame, aluminum double-doors, and single pane glass panes believed to have been added in the mid-60s. The proposal replaces aluminum framing and glazing with new aluminum framing and glazing. Therefore, this like for like material replacement it is not subject to the review standards of ADC 7.200 and 7.210.

Lastly, the application includes installation of a flexible LED lighting material contained in aluminum channeling along the back side of cornice. However, ADC 7.170 does not include substitute lighting material; therefore, this item is not subject to review via ADC 7.210.

As such, eligibility for the use of substitute materials (ADC 7.200) and review criteria for Historic Review of the Use of Substitute Materials (ADC 7.210) are addressed in this report for the proposed development. Code criteria are written in **bold** followed by findings and conclusions.

Eligibility for the Use of Substitute Materials (ADC 7.200)

The City of Albany interprets the Secretary of Interior's Standards for Rehabilitation on compatibility to allow substitute siding and windows only under the following conditions:

1. The building or structure is rated historic non-contributing; OR
2. In the case of historic contributing buildings or structures, the existing siding, windows, or trim is so deteriorated or damaged that it cannot be repaired and finding materials that would match the original siding, windows or trim is cost prohibitive. [OBJ]

Any application for the use of substitute siding, windows, and/or trim will be decided on a case-by-case basis. The prior existence of substitute siding and/or trim on the historic buildings on the Local Historic Inventory will not be considered a factor in determining any application for further use of said materials.

To be able to use substitute material, the applicant must first demonstrate that subject materials meet the eligibility requirements per ADC 7.200. Should the Landmarks Commission (LC) find one of the eligibility thresholds for the use of substitute materials is met, an analysis of ADC 7.210 is provided below regarding the proposed substitute material(s).

Findings of Fact

- 2.1 Eligibility. The subject building is rated as a Historic Contributing resource in the Downtown National Register Historic District. Therefore, the thresholds in ADC 7.200(2) must be met for eligibility: 1) the existing materials are so deteriorated and damaged that they cannot be repaired; and 2) finding materials that would match the original is cost prohibitive.
- 2.2 Existing Conditions.

The existing conditions of the items proposed to be replaced with substitute materials are as follows:

- a. Basement Window Openings: Nine infilled window openings. Five rotten wood frames/sashes. Two metal bar inserts.
- b. Rear South Elevation Window: One rotten wood frame/sash.
- c. Exterior Vestibule: Corroded aluminum framing. Clouded and scratched glazing.

- 2.3 Substitute Materials.

Proposed substitute materials are as follows:

- a. Basement Window Openings: The applicant proposes to replace infilled basement window openings and five rotten wood windows and frames with Andersen, A-Series Fibrex exterior and wood interior window type and metal bar inserts. Fibrex is a PVC-wood composite material. Window replacement will allow light into the basement, which will be used as active space after the remodel. The composite material will better prevent rotting from occurring as these windows are at-grade and more susceptible to moisture and water intrusion. Metal bars will help deter breakage.
- b. Rear South Elevation Window: The applicant proposes to partially in-fill and replace one rotten/damaged wood window and frame on the rear (south) elevation with Andersen, A-Series Fibrex exterior and wood interior window type. Fibrex is a PVC-wood composite material.
- c. Exterior Vestibule: The applicant proposes to replace the existing aluminum exterior vestibule. All windows and door frames of the exterior vestibule are proposed to be replaced with fixed clear anodized aluminum storefront frames and insulated fixed glass. Existing aluminum entry doors and transoms are proposed to be replaced with anodized aluminum doors with a narrow stile and insulated tempered, transparent glass.

The main purpose of retaining the vestibule is to aid in controlling the exchange of heat between outside and the building's interior. The secondary purpose is to remove existing corroded aluminum with new aluminum and clouded and scratched windowpanes with clear, double paned, thermal storefront windows.

- 2.4 **Costs.** A cost analysis was not included in the application submittal nor is one required per ADC 7.190. In this case, the cost of replacement material and long-term maintenance of such material would be cost prohibitive for the project.

Review criteria regarding this proposal are provided below along with an analysis of the proposal's conformance with the criteria.

Design and Application Criteria for the Use of Substitute Materials (ADC 7.210)

Criteria 1 through 3, Material Dimensions and Finish

1. The proposed substitute materials must approximate in placement, profile, size, proportion, and general appearance of the existing siding, windows, or trim.
2. Substitute siding, windows and trim must be installed in a manner that maximizes the ability of a future property owner to remove the substitute materials and restore the structure to its original condition using traditional materials.
3. The proposed material must be finished in a color appropriate to the age and style of the house, and the character of both the streetscape and the overall district. The proposed siding or trim must not be grained to resemble wood.

Findings of Fact and Conclusions

- 2.5 Detailed architectural drawings are enclosed and depict placement, profile, size, proportion, and general appearance of existing and proposed materials.
- 2.6 All installed materials can be removed and replaced later if needed without considerable damage to the structure.
- 2.7 None of the window components will be grained to resemble wood.

Criterion 4 through 6, Decorative Features and Unusual Examples of Historic Siding and Windows

4. The proposed siding, windows or trim must not damage, destroy, or otherwise affect decorative or character-defining features of the building. Unusual examples of historic siding, windows and/or trim may not be covered or replaced with substitute materials.
5. The covering of existing historic wood window or door trim with substitute trim will not be allowed if the historic trim can be reasonably repaired. Repairs may be made with fiberglass or epoxy materials to bring the surface to the original profile, which can then be finished, like the original material.
6. Substitute siding or trim may not be applied over historic brick, stone, stucco, or other masonry surfaces.

Findings of Fact and Conclusions

- 2.8 The substitute windows and frames will not be installed over, or cover unusual examples of, historic windows or trim or decorative and character-defining features of the building.
- 2.9 No decorative or character-defining features of the building would be impacted. As such, criteria 4 through

6 are satisfied.

Criterion 7 through 13: Siding and Trim Preparation and Installation

For the application of substitute siding and trim only:

7. The supporting framing that may be rotted or otherwise found unfit for continued support shall be replaced in kind with new material.
8. The interior surface of the exterior wall shall receive a vapor barrier to prevent vapor transmission from the interior spaces.
9. Walls to receive the proposed siding shall be insulated and ventilated from the exterior to eliminate any interior condensation that may occur.
10. Sheathing of an adequate nature shall be applied to support the proposed siding material with the determination of adequacy to be at the discretion of the planning staff.
11. The proposed siding shall be placed in the same direction as the historic siding.
12. The new trim shall be applied so as to discourage moisture infiltration and deterioration.
13. The distance between the new trim and the new siding shall match the distance between the historic trim and the historic siding.

Findings of Fact

- 2.10 No substitute siding or wall trim is proposed in association with this application. These criteria are not applicable to this submittal.

Conclusions

- 2.1 The existing vestibule windows and frames material are believed to be installed in the mid-60's. The material is beyond repair. The applicant proposes to remove existing vestibule windows and frames and replace them with thermal panes and anodized aluminum storefront frames.
- 2.2 The proposed new windows and frames will not destroy, or otherwise affect the character-defining features of the structure.
- 2.3 The criteria and guidelines for the use of substitute materials can be satisfied as proposed.

Criterion 14

A good faith effort shall be made to sell or donate any remaining historic material for architectural salvage to an appropriate business or non-profit organization that has an interest in historic building materials.

Findings of Fact and Conclusions

- 2.11 Any historic material being removed is rotten and beyond repair; Therefore, salvage is not proposed.
- 2.12 This criterion is satisfied.

Overall Conclusion

Based on the above analysis, the proposed application meets all the applicable decision criteria as outlined above.

Exhibits

- A. Architectural Plan Set
- B. Andersen A-Series Product Guide
- C. Lighting Package

A-SERIES



**ARCHITECTURAL
AUTHENTICITY
WITH UNPARALLELED
PERFORMANCE.**

CONTENTS

Innovation & Performance	2-3
Design	4-5
Window & Door Types	7
Exteriors & Interiors	8-9
Window Hardware	11
Patio Door Hardware	12-13
Glass	14-15
Art Glass & Insect Screens	16-17
Grilles	19
Easy Connect Joining System	20

A-SERIES WINDOWS

Windows	21
Casement Windows	26
Awning Windows	32
Double-Hung Windows	38
Picture Windows	44
Transom Windows	52
Specialty Windows	67
Complementary Casement Windows	113

A-SERIES PATIO DOORS

Patio Doors	119
Gliding Patio Doors	126
Hinged Inswing Patio Doors	134
Hinged Outswing Patio Doors	150
Patio Door Sidelights & Transoms	156
Complementary Curved Top Patio Doors	177

Exterior Trim	189
---------------------	-----

Combination Designs	196
Product Performance	206
Installation Accessories & Information	226
Sustainability	228

For warranty information, visit andersenwindows.com/warranty.



Andersen Corporation, including its subsidiaries, has been named a 2022 ENERGY STAR® Partner of the Year – Sustained Excellence Award winner, the highest honor given by ENERGY STAR, for continued leadership in protecting the environment through superior energy efficiency achievements.



“ENERGY STAR” is a registered trademark of the U.S. Environmental Protection Agency.



AMERICA'S MOST LOVED BRAND OF WINDOWS & DOORS.*

You want to give your customers a home they love, and we're here to make that easy for you. That's why we're proud to offer you products that rate #1 in quality and performance,** and to be the #1 trusted and recommended window and door brand:

A-SERIES PRODUCTS

Designed in collaboration with architects, A-Series products are our most fine-tuned windows and doors. Their matching sight lines, matching glass setbacks and size options will help you bring any architectural style to life down to the smallest detail. And with numerous glass options and composite exteriors, they're our best performing and most energy-efficient products capable of withstanding the toughest conditions.

*2022 Andersen brand surveys of U.S. realtors, contractors, builders and homeowners.

**2022 Andersen brand surveys of U.S. contractors, builders and architects.

UNPARALLELED INNOVATION & PERFORMANCE

The beauty of A-Series products goes beyond their architecturally detailed designs. They're also the best-performing, most energy-efficient windows and patio doors we've ever engineered. With environmental and impact certifications,* they can help you achieve almost anything.

BUILT STRONG

We use solid wood in interior door panels and window sash and frames plus fiberglass on outer door frames and window sash exteriors to provide an unmatched combination of strength, insulation, versatility and beauty.

Additionally, our Fibrex® composite material used in window frames and trim components delivers twice the strength and rigidity of vinyl.



WATER MANAGEMENT THAT WORKS

These features work together to direct water away from buildings:

- Hermetically sealed corner keys keep frames tight
- Sloped sill on double-hung windows
- Sill on patio doors channels water away from the home
- Innovative trim attachment flange secures trim independent of the window or door's water management system

VIRTUALLY MAINTENANCE-FREE EXTERIORS

Exteriors of A-Series products never need painting. They won't flake, rot, blister, peel, pit or corrode.** Plus they're warranted against corrosion for the life of the products† with no washing or waxing required.**



QUALITY SO SOLID, THE WARRANTY IS TRANSFERABLE**†

Our renowned Owner-2-Owner® limited warranty is fully transferable and not prorated, making it one of the best coverage plans available — which means it can add resale value for your customers. It's also supported by the industry's largest service network.

**OWNER2OWNER®
LIMITED WARRANTY**

ARCHITECTURAL AUTHENTICITY

A-Series products and their detailed design options make architectural authenticity not only possible but also easy to achieve. To find A-Series windows, doors, hardware, exterior trim and color palettes that are authentic to a particular home's architectural style, see our style library at andersenwindows.com/stylelibrary.

ENERGY-SAVING GLASS AND DESIGN

Andersen makes windows and doors with options that make them ENERGY STAR® v. 6.0 certified throughout the United States.

Visit andersenwindows.com/energystar for more information and contact your dealer to verify that the product with your glass option is ENERGY STAR certified in your area.



PHIUS CERTIFICATION **NEW!**

A-Series casement, awning and fixed transom windows are Phius (Passive House Institute US) certified, helping you work your designs toward a zero-carbon footprint.



*Available on select A-Series products.

**Visit andersenwindows.com/warranty for details.

†Hardware excluded.

All logos and marks are trademarks of their respective owners.

RIGOROUSLY TESTED

A-Series products have withstood testing that has taken them from temperatures as cold as Alaskan winters to the heat of Death Valley summers. They've stood up to hurricane-force winds and prolonged exposure to sea air.* A-Series standard products feature the following ratings:†

Windows	PG50 (DP50)
Gliding Patio Doors	PG50 (DP50)**
Hinged Patio Doors	PG45 (DP45)

PG50[†]

ADH4080 +50/-50
(AAMA/WDMA/CSA 101/1.5.2/A440-11)

Ratings vary by product performance and unit size. See the performance section in this guide for specific unit performance. Visit andersenwindows.com for up-to-date performance values.

SEALS OUT THE WEATHER

Weather-resistant seals stand up to eight inches of rain per hour and hurricane-force winds.† Double-hung windows feature a dual-bulb seal, and casement windows use refrigerator-type gaskets to help keep air and water out.

PERFORMANCE GRADE **NEW!** (PG) UPGRADES

PG upgrades are now available for A-Series windows, in addition to A-Series patio doors. Products with PG upgrades achieve higher air, water and structural ratings as opposed to standard performance products. Availability is based on product type and size.

PG70^{††}

ADH4080 PGLUP +70/-70
(AAMA/WDMA/CSA 101/1.5.2/A440-11)

OPTIONS FOR THE HARSHTEST WEATHER

A-Series products are available with Stormwatch® Protection to achieve higher air, water and structural ratings. They also include impact-resistant glass for wind-borne debris protection to maintain the structural integrity of the unit after impact. Visit andersenwindows.com/coastal or refer to the Andersen® A-Series Coastal Product Guide for more information. See your local building code official for specific requirements.

PG70^{††}+

ADH4080 SW Impact +70/-70
(AAMA/WDMA/CSA 101/1.5.2/A440-11)

StormWATCH
PROTECTION

*Tested to AAMA/WDMA/CSA 101/1.5.2/A440-08 & -11 PG50.

**Rating applies to all gliding patio doors except two-panel 10' tall doors (PG45) and three- and four-panel 8' and 10' tall doors (PG40).

†ADH4080 +50/-50 (AAMA/WDMA/CSA 101/1.5.2/A440-11). For more information, visit andersenwindows.com/a-series.

††ADH4080 PGLUP +70/-70 (AAMA/WDMA/CSA 101/1.5.2/A440-11). For more information, visit andersenwindows.com/a-series.

‡ADH4080 SW Impact +70/-70 (AAMA/WDMA/CSA 101/1.5.2/A440-11). For more information, visit andersenwindows.com/coastal.





ARCHITECTURALLY DETAILED DESIGN

COMMON SIZE GRID

Common sizes in 4" (102) increments are based on the rough opening to simplify framing and specifying. Even-inch sizes eliminate fractions and reduce job site errors. A 3/4" (19) gap horizontally and vertically leaves room for shims, insulation and sill flashing.

CUSTOM SIZING

All A-Series windows and patio doors can be ordered in 1/8" (3) increments, providing flexibility for replacement, remodeling, new construction and light commercial projects.

COMMON GLASS SETBACK

A common glass setback on A-Series windows and patio doors delivers noticeably clean shadow lines both inside and out.

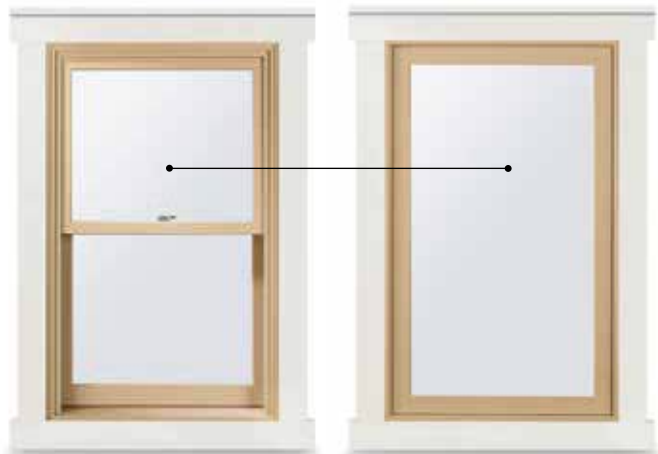

The upper sash of double-hung windows aligns perfectly with casement windows, awning windows, picture windows, patio doors and transoms.

Dimensions in parentheses are in millimeters.

COMPLETE ALIGNMENT

Common sight lines allow you to specify any combination of window styles and still have them match and align perfectly.



Windows share the same sash design, grille profiles and frame depth for consistent beauty with classic appeal.



EASY MATH

The A-Series window system simplifies selection and installation of multiple windows within a single rough opening. 3/4" (19) horizontal and vertical joints keep sizing consistent no matter how many or what size windows you combine.

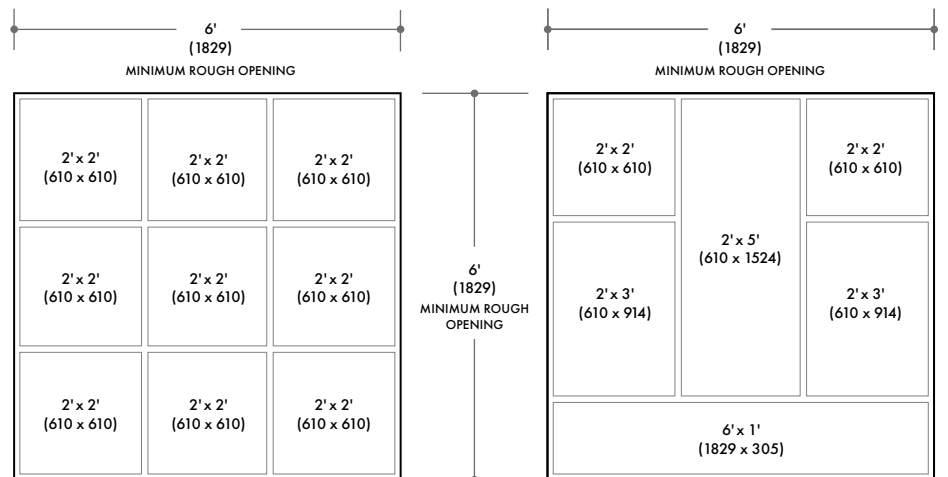

The spacing in these illustrations is exaggerated for demonstration purposes.



ANDERSEN® PRODUCTS
**RATE #1 IN
QUALITY AND
PERFORMANCE.***

WINDOW & DOOR TYPES

A-SERIES WINDOWS

The A-Series window lineup consists of casement, awning, double-hung, picture, transom (fixed or venting) and specialty shape windows. Every type is meticulously designed to fit a variety of different architectural styles. And with common sight lines they're designed to align perfectly no matter how you combine them.

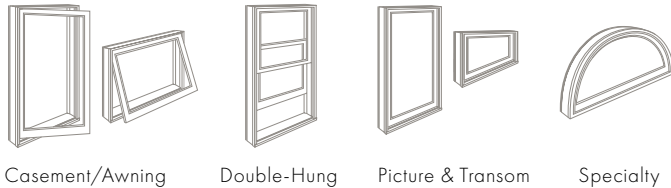

A-SERIES PATIO DOORS

The A-Series door lineup consists of gliding and hinged patio doors (inswing and outswing) with options to add sidelights and transoms for an even stronger connection to the outdoors.

Contemporary Panels **NEW!**

The new A-Series contemporary panels have a 6 1/4" (159) bottom rail as opposed to traditional panels with a 10 1/2" (267) bottom rail. Matching patio door sidelights and transoms are available.

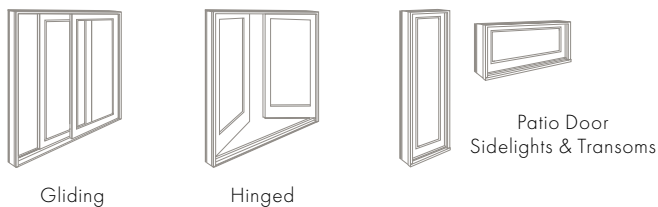

COMPLEMENTARY CASEMENT WINDOWS

Our complementary casement windows offer easy operation along with old-world style. They include French casements — twin sash inside one frame with no mullion post between them like ordinary casements — that give you a totally unobstructed view. Complementary casement windows are available in rectangles, trapezoids and a variety of arched shapes.



COMPLEMENTARY CURVED TOP PATIO DOORS

With features like Romanesque arches and sweeping curves, nothing else quite matches the grandeur our complementary curved top inswing and outswing patio doors can bring to a home.



EXTERIORS

A-Series products are available in a wide range of exterior colors and exterior trim choices. Even in harsh conditions they're virtually maintenance free, hold their original vibrant colors, never need painting and won't flake, rot, blister, peel, pit or corrode.* Select any combination of colors shown here for your exterior frame, sash and trim.

EXTERIOR COLORS

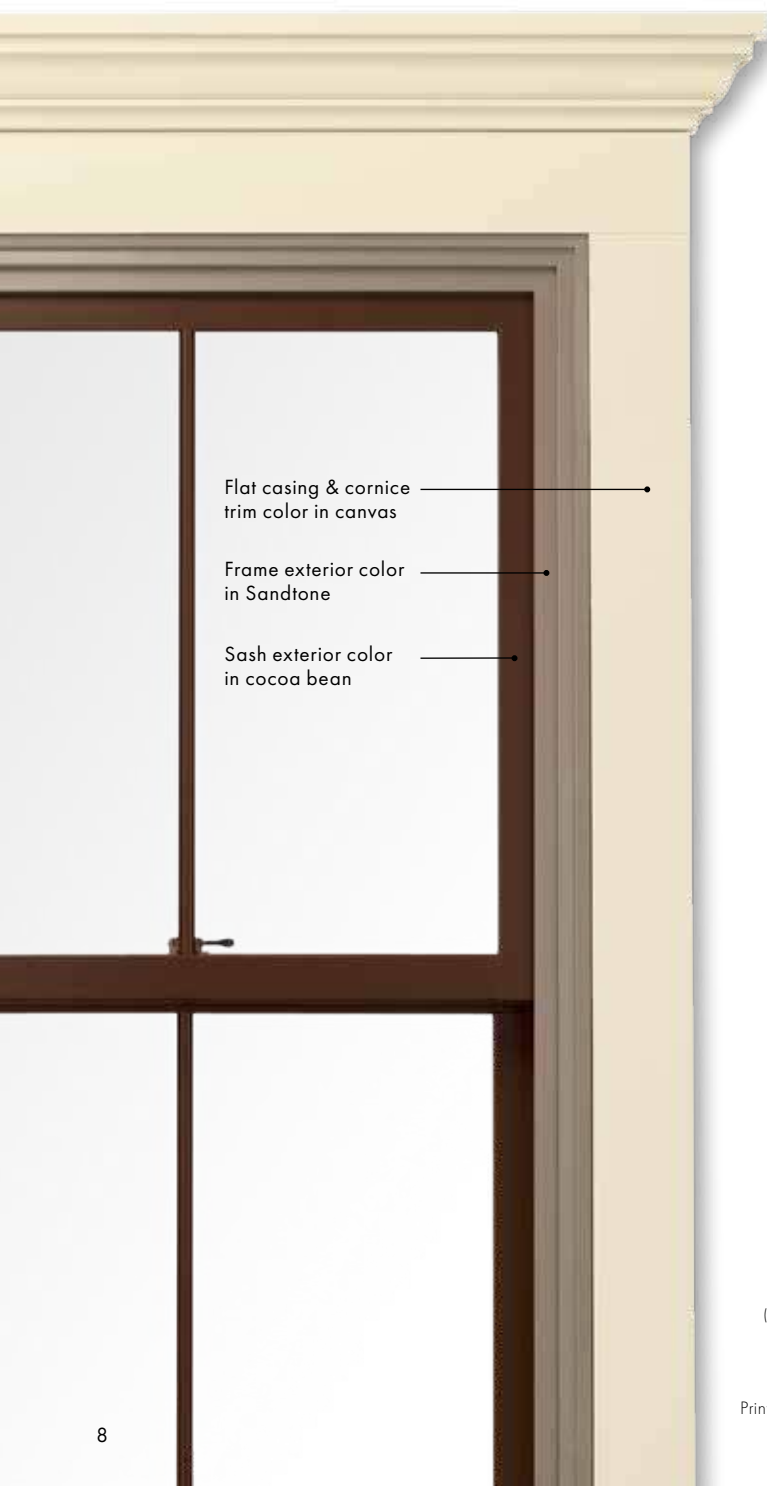

EXTERIOR TRIM SYSTEM

- Complements a wide range of architectural styles
- Low maintenance and never needs painting
- Order as pre-assembled surrounds, in precut kits or as individual components
- Innovative trim attachment flange on A-Series windows allows pre-assembled exterior trim surrounds to be installed in seconds
- Installed independent of the window's or door's water management system
- For more information, see the exterior trim section starting on page 191.

EXTERIOR TRIM STYLE OPTIONS



Flat Casing
(flush head)



Flat Casing
(extended head)



Brick Mould



Flat Casing &
Decorative Drip Cap



Flat Casing & Cornice



Flat Casing & Cornice



Brick Mould & Sill Nose
(extended sill nose, also available
with flush sill nose)



Flat Casing
(flush sill)



Flat Casing
(extended sill)

*Visit andersenwindows.com/warranty for details.

Printing limitations prevent exact duplication of colors. See your Andersen supplier for actual color samples.

INTERIORS

With six natural wood species, six rich factory-finished stain options and a variety of painted interiors, A-Series products provide the flexibility to create interiors that please both you and your customers.

INTERIOR WOOD SPECIES



FACTORY-FINISHED INTERIORS

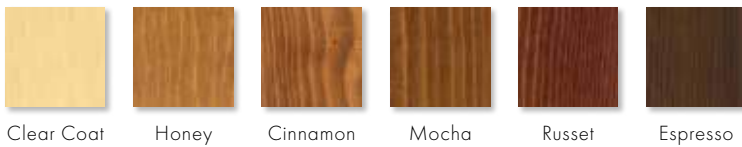

All wood interiors are unfinished unless a finish is specified. For windows, clear coat is now available on all wood species; all other factory finishes are available on pine, maple and oak. For doors, factory finishes are available on pine, maple and oak. Finishes shown above on pine. **NEW!**

INTERIOR PAINT COLORS

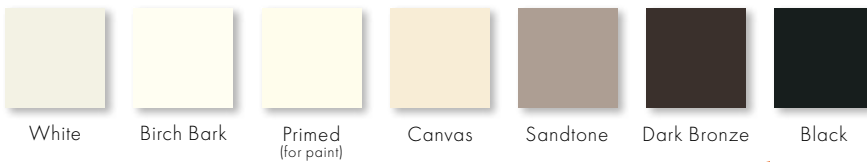

For windows, painted interiors are now available on maple in addition to pine. For doors, painted interiors are available on pine. Additional colors to match all 11 exterior colors are also available; see your Andersen supplier for details. **NEW!**

4-TONE INTERIORS **NEW!**

Mix and match up to four interior wood species, stains and/or colors for your window's frame, sash, grilles and extension jambs to achieve a look unique to your project.

*Actual wood species is either Sapele or Sipo, both non-endangered species grown in Africa, with color and characteristics similar to Central American mahoganies. Naturally occurring variations in grain, color and texture of wood make each window one of a kind. We cannot guarantee consistency in wood grain and/or color within a particular species, product or project. Printing limitations prevent exact duplication of colors. See your Andersen supplier for actual color samples.





ANDERSEN® IS THE
WINDOW & DOOR BRAND
HOMEOWNERS
RECOGNIZE
THE MOST.*

*2022 Andersen brand survey of U.S. homeowners.

WINDOW HARDWARE

The hardware* for our A-Series windows is created exclusively for Andersen and is made of forged metal for added strength. A range of available finishes makes it easy for customers to coordinate their window hardware with their cabinet hardware, faucets and other room décor.

Casement, Awning & Venting Transom



CONTEMPORARY FOLDING

Black | Bright Brass | Oil Rubbed Bronze
Satin Nickel | Stone | White



TRADITIONAL FOLDING

Antique Brass | Black | Bright Brass | Distressed Bronze
Distressed Nickel | Oil Rubbed Bronze | Satin Nickel
Stone | White

Folding handles avoid interference with window treatments.
Bold name denotes finish shown.

Double-Hung



Lock & Keeper

Antique Brass | Black | Bright Brass | Distressed Bronze | Distressed Nickel
Oil Rubbed Bronze | **Satin Nickel** | Stone | White



Optional Bar Lift



Optional Hand Lift



Optional Finger Lift

Antique Brass | Black | Bright Brass | Distressed Bronze | Distressed Nickel
Oil Rubbed Bronze | **Satin Nickel** | Stone | White

Bold name denotes finish shown.

HARDWARE FINISHES



Antique
Brass

Black

Bright Brass

Distressed
Bronze

Distressed
Nickel

Oil Rubbed
Bronze

Satin Nickel

Stone

White



EASY TILT-TO-CLEAN

A-Series double-hung windows include a tilt-to-clean feature, with one hand operation, for easy exterior glass cleaning of both sash.

*Hardware sold separately except double-hung lock and keeper. Distressed bronze and oil rubbed bronze are "living" finishes that will change with time and use.

Printing limitations prevent exact replication of finishes. See your Andersen supplier for actual finish samples.

Historic Federal Building



Lighting Package

September 2024

L1: Column Light

Installed in Ground. No contact with building.
Accents all pilasters around building perimeter.
Locations noted on Site Plan.





M9700C

In-Grade Luminaire

HIGHLIGHTS

- Factory-sealed LED lamp module and encapsulated power module
- Optical and mechanical aiming with an optional double lens
- Optimal efficiency through photometric improvements
- Color temperature: 27K - 50K
- In-line & 0-10V Dimming
- Flow-through technology
- IK08 (IK10 option available)

5
YEAR
warranty



IP68



Specifications	SINGLE LENS	DOUBLE LENS
Length:	12"	12"
	305 mm	305 mm
Width:	12"	12"
	305 mm	305 mm
Height:	16"	16"
	407 mm	407 mm
Weight:	25lbs	27lbs

Weight is based on aluminum material.
For B and SS material add 2lbs.

DIMENSIONS

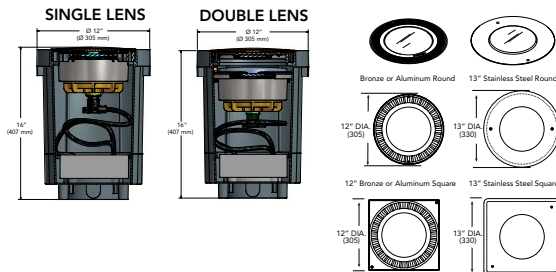

LUMEN PACKAGES

	NSP	NFL	MFL	FL	WFL	WWD
Delivered Lumens	4,205	3,786	3,537	3,576	3,320	2,871
Watts	35	35	35	35	35	35
LPW	120	110	108	101	95	82
Peak Candela	40,082	10,183	5,440	3,417	2,225	2,649

Note: Information based on 4000K @ P2 Performance Package - Single lens (M9710C and M9730C)

STANDARD DISTRIBUTION

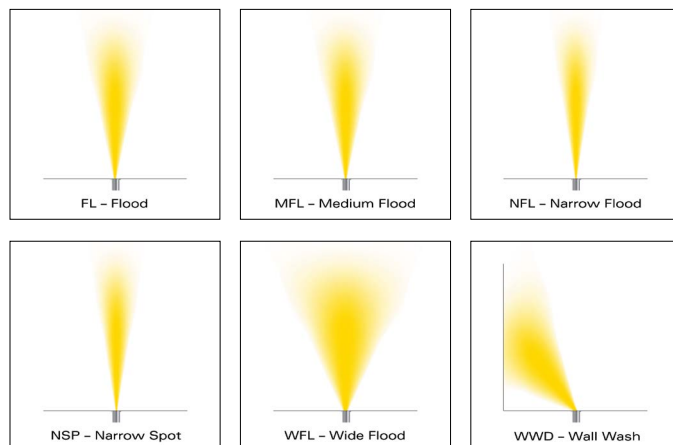

AIMING DETAILS

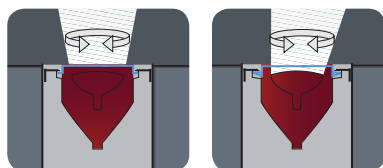

Single lensed fixture can be aimed using
10° and 20° optical tilt lenses only.

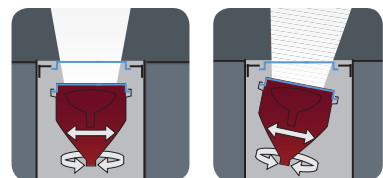

Double lens, mechanically and optically aimed.

ORDERING INFORMATION

EXAMPLE: M9720C SS LED P3 40K MVOLT NSP FLC 34S

Model*	Door Material*	Source*	Performance Package*	LED Color*	Voltage*	Distribution*	Lens ^{3*}
M9710C	Round Door, Single Lens	A Aluminum	LED P1 29W	27K 2700K	MVOLT (120 - 277 volt 50/60HZ)	NSP Narrow Spot	FLC Flat Lens Clear
M9720C	Round Door, Double Lens	B Bronze	P2 35W	30K 3000K		NFL Narrow Flood	FLC5 Flat Lens Clear, 5° Axial Spread
M9730C	Square Door, Single Lens	SS Stainless Steel	P3 46W	35K 3500K		MFL Medium Flood	FLC10 Flat Lens Clear, 10° optical tilt
M9740C	Square Door, Double Lens	<i>Note: Aluminum material is not available with M9730C and M9740C square door</i>	P4 ¹ 53W	40K 4000K		FL Flood	FLC20 Flat Lens Clear, 20° optical tilt
				50K 5000K		WFL Wide Flood	FLF Flat Lens Frosted
						WWD ^{1,2} Wall Wash	FLCAS Flat Lens Clear, Anti-Slip
							FLC5AS Flat Lens Clear, 5° Axial Spread, Anti-Slip

Lens (cont.)	Conduit Entries*	Accessories	Options	Finish ¹⁰	Listing
FLCSR ⁴	12B 1/2" NPT Bottom	Internal ^{6,7}	LDIM 0-10V Dimming (Dims to 10%)	BL Black	IEC ⁴ International Electro-technical Commission (50HZ applications only)
FLCSR ⁴	12S 1/2" NPT Side	IHL Internal Honeycomb Louver	IDIM ⁹ Inline Dimming (Dims to 40%)	BZ Bronze	
FLC5SR ⁴	34B 3/4" NPT Bottom	LSF Linear Spread Filter		DDB Dark Bronze	
FLC10SR ⁴	34S 3/4" NPT Side	External ^{6,8}		DNA Natural Alum.	
FLC20SR ⁴	25S ⁵ 25mm Side	GS Glare Shield		GN Green	
	<i>Note: Two (2) bottom or side entries available</i>	LC ⁸ Lexan Cover		GR Gray	
		LS Light Shield		SND Sand	
		RG Rock Guard		STG Steel Gray	
		<i>Note: For IK10 use external RG option</i>		TVG Terra Verde Green	
		Trim Ring ^{6,8}		WH White	
		BTR Brass Round		_Z ¹¹ Zinc Undercoat (i.e. BLZ)	
		BTS Brass Square			
		STR Stainless Round			
		STS Stainless Square			

Note: * is a required field

ELECTRICAL LOAD

Light Engines	Drive Current (mA)	System Watts	Current (A)			
			120	208	240	277
P1	250mA	29	0.24	0.14	0.12	0.10
P2	300mA	35	0.29	0.17	0.15	0.13
P3	400mA	46	0.38	0.22	0.19	0.17
P4	450mA	53	0.44	0.25	0.22	0.19

PROJECTED LED LUMEN MAINTENANCE

Data references the extrapolated performance projections for the Fixture platform in a 25°C ambient, based on 13,000 hours of LED testing (tested per IESNA LM-80-08 and projected per IESNA TM-21-11).

To calculate LLF, use the lumen maintenance factor that corresponds to the desired number of operating hours below. For other lumen maintenance values, contact factory.

Based on 2700K-5000K LED color

Operating Hours	0	25,000	50,000	100,000
Lumen Maintenance Factor	1.00	0.94	0.93	0.92

Notes:

- P4 and WWD distribution are not available with double lens.
- Recommended to use the FLF or FLCSR lens with the WWD.
- Specify top lens. Bottom lens is FLC standard on M9720C and M9740C.
- Meets ADA requirements for coefficient of friction.
- Only for use in 50HZ applications.
- Accessories are mutually exclusive, choose one only.
- Not available with FLC10, FLC20, FLC10SR or FLC20SR.
- External accessory not available with SS door material.
- IDIM forward phase dimming not available with P3. IDIM option should be run at 120 volt.
- Finish only available on "A" door material.
- Add Zinc undercoat for harsh environments.

LUMEN AMBIENT TEMPERATURE (LAT) MULTIPLIERS

Use these factors to determine relative lumen output for average ambient temperatures from 0-40°C (32-104°F).

Ambient	Lumen Multiplier
0°C	1.02
10°C	1.01
20°C	1.00
25°C	1.00
30°C	1.00
40°C	0.99

M9700C LED Series Assembly consists of the following individual components parts	MRISC97 Rough-In Housing MFSC97 Finishing Section MACLC LED Module MHSLC97 Power Module
---	--

PERFORMANCE DATA

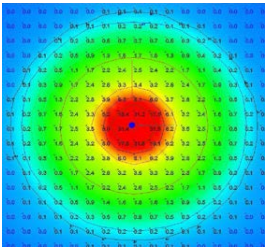

NSP 2x2

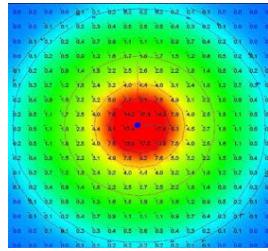

NFL 3x3

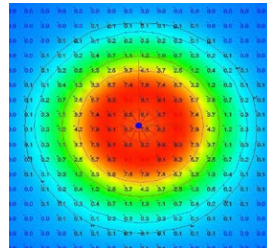

MFL 4x4

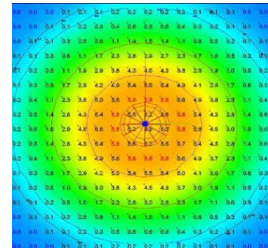

FL 5x5

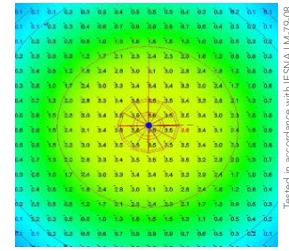

WFL 6x6

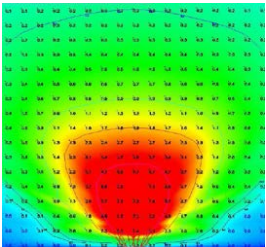

WWD 6x5

To see complete photometric reports or download .ies files for this product, visit www.hydrrel.com

Maximum Lens Temperature
SINGLE LENS OPTION: 54°C
DOUBLE LENS OPTION: 44°C

SLIP RESISTANCE AND LOAD RATING

M9700C LED
MAXIMUM LOAD RATING
Peak compression force of 3,750 lbs. (single lens), 3,200 lbs. (double lens).
LENS STATIC COEFFICIENT OF FRICTION
M9700 Anti-Slip Lens (FLCAS): Dry = 0.76; Wet = 0.10
M9700 Slip Resistant Lens (FLCSR): Dry = 0.84; Wet = 0.65

PERFORMANCE DATA

LUMEN OUTPUT – SINGLE LENS (M9710C AND M9730C)

Lumen values are from photometric tests performed in accordance with IESNA LM-79-08. Data is considered to be representative of the configurations shown, within the tolerances allowed by Lighting Facts. Actual performance may differ as a result of end-user environment and application. Contact factory for performance data on any configurations not shown here.

Performance Package	System Watts	Distribution Type	Field Angle		Beam Angle		27K (2700K, 80CRI)			30K (3000K, 80CRI)			35K (3500K, 80CRI)			40K (4000K, 80CRI)			50K (5000K, 80CRI)		
			°H	°V	°H	°V	Max Cd	Lumens	LPW	Max Cd	Lumens	LPW	Max Cd	Lumens	LPW	Max Cd	Lumens	LPW	Max Cd	Lumens	LPW
P1	29W	NSP	27	27	13	13	31487	3303	114	32579	3418	118	33557	3520	121	34283	3597	124	34403	3609	124
		NFL	72	72	26	26	7999	2975	103	8277	3078	106	8525	3170	109	8710	3239	112	8740	3250	112
		MFL	58	64	43	52	4274	2779	96	4422	2875	99	4555	2961	102	4653	3025	104	4670	3036	105
		FL	85	78	69	58	2684	3029	104	2777	3134	108	2861	3228	111	2923	3298	114	2933	3309	114
		WFL	102	93	78	62	1748	2608	90	1809	2699	93	1863	2780	96	1903	2840	98	1910	2850	98
P2	35W	NSP	27	27	13	13	36813	3862	110	38089	3996	114	29233	4116	118	40082	4205	120	40222	4220	121
		NFL	72	72	26	26	9352	3478	99	9677	3598	103	9967	3706	106	10183	3786	108	10219	3800	109
		MFL	58	64	43	52	4997	3249	93	5170	3361	96	5325	3462	99	5440	3537	101	5459	3550	101
		FL	85	78	69	58	3138	3541	101	3247	3664	105	3345	3774	108	3417	3856	110	3429	3869	111
		WFL	102	93	78	62	2044	3050	87	2115	3155	90	2178	3250	93	2225	3320	95	2233	3332	95
P3	46W	NSP	27	27	13	13	47243	4956	108	48881	5128	111	50349	5282	115	51438	5396	117	51618	5415	118
		NFL	72	72	26	26	12002	4463	97	12419	4618	100	12791	4756	103	13068	4859	106	13114	4876	106
		MFL	58	64	43	52	6412	4169	91	6635	4314	94	6834	4443	97	6982	4539	99	7006	4555	99
		FL	85	78	69	58	4027	4545	99	4167	4702	102	4292	4843	105	4385	4948	108	4400	4966	108
		WFL	102	93	78	62	2623	3914	85	2714	4049	88	2795	4171	91	2856	4261	93	2866	4276	93
P4	53W	NSP	27	27	13	13	52859	5545	105	54692	5738	108	56334	5910	112	57552	6038	114	57754	6059	114
		NFL	72	72	26	26	13429	4993	94	13895	5167	97	14312	5322	100	14621	5437	103	14673	5456	103
		MFL	58	64	43	52	7175	4665	88	7423	4827	91	7646	4972	94	7812	5079	96	7839	5097	96
		FL	85	78	69	58	4506	5085	96	4662	5261	99	4802	5419	102	4906	5536	104	4923	5556	105
		WFL	102	93	78	62	2935	4379	83	3037	4531	85	3128	4667	88	3195	4768	90	3207	4784	90
WFL	114	78	74	51	3493	3786	71	3614	3917	74	3723	4035	76	3803	4122	78	3817	4137	78		

LUMEN OUTPUT – DOUBLE LENS (M9720C AND M9740C)

Lumen values are from photometric tests performed in accordance with IESNA LM-79-08. Data is considered to be representative of the configurations shown, within the tolerances allowed by Lighting Facts. Actual performance may differ as a result of end-user environment and application. Contact factory for performance data on any configurations not shown here.

Performance Package	System Watts	Distribution Type	Field Angle		Beam Angle		27K (2700K, 80CRI)			30K (3000K, 80CRI)			35K (3500K, 80CRI)			40K (4000K, 80CRI)			50K (5000K, 80CRI)		
			°H	°V	°H	°V	Max Cd	Lumens	LPW	Max Cd	Lumens	LPW	Max Cd	Lumens	LPW	Max Cd	Lumens	LPW	Max Cd	Lumens	LPW
P1	29W	NSP	30	30	13	13	25622	2868	99	26510	2967	102	27306	3056	105	27897	3122	108	27994	3133	108
		NFL	62	62	27	25	7147	2507	86	7394	2594	89	7617	2672	92	7781	2730	94	7808	2739	94
		MFL	66	56	52	39	3969	2490	86	4107	2577	89	4230	2654	92	4322	2711	93	4337	2721	94
		FL	83	75	63	50	2576	2496	86	2665	2583	89	2745	2660	92	2805	2718	94	2815	2727	94
		WFL	97	90	67	55	1691	1975	68	1750	2044	70	1803	2105	73	1842	2150	74	1848	2158	74
P2	35W	NSP	30	30	13	13	29956	3353	96	30994	3469	99	31925	3573	102	32616	3650	104	32730	3663	105
		NFL	62	62	27	25	8355	2931	84	8645	3033	87	8905	3124	89	9097	3191	91	9129	3202	91
		MFL	66	56	52	39	4641	2911	83	4802	3012	86	4946	3103	89	5053	3170	91	5071	3181	91
		FL	83	75	63	50	3012	2918	83	3116	3020	86	3210	3110	89	3279	3177	91	3291	3189	91
		WFL	97	90	67	55	1978	2309	66	2046	2389	68	2108	2461	70	2153	2514	72	2161	2523	72
P3	46W	NSP	30	30	13	13	38443	4303	94	39776	4452	97	40971	4586	100	41857	4685	102	42003	4701	102
		NFL	62	62	27	25	10723	3761	82	11095	3892	85	11428	4009	87	11675	4095	89	11716	4110	89
		MFL	66	56	52	39	5956	3736	81	6162	3866	84	6347	3982	87	6485	4068	88	6507	4082	89
		FL	83	75	63	50	3865	3745	81	3999	3875	84	4119	3991	87	4208	4078	89	4223	4092	89
		WFL	97	90	67	55	2538	2963	64	2626	3066	67	2705	3158	69	2763	3226	70	2773	3238	70

OPERATING TEMPERATURE: -30°C through 50°C P1 & P2; -30°C through 40°C P3

ACCESSORIES

INTERNAL

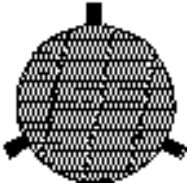

INTERNAL HONEYCOMB LOUVERS — IHL

Hexagonal cell louver with 45° cut-off.

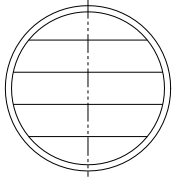

LINEAR SPREAD FILTER — LSF

6.68" diameter, spreads the beam of light along one axis only. May be oriented to spread the light horizontally or vertically.

EXTERNAL

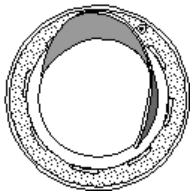

QUARTER GLARE SHIELDS — GS

Rolled sheet aluminum or brass. 360° of adjustment on fixture door, with lock down. May be field installed to door as shown.

(Not recommended for foot traffic areas.)

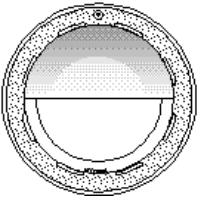

HALF LIGHT SHIELD — LS

(Quarter Spherical External)

Cast aluminum or bronze shield for glare control for wall wash units. 360° adjustment allows field setting and lock down. May be field installed to door as shown.

(Not recommended for foot traffic areas.)

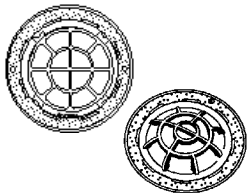

ROCKGUARD — RG

Cast aluminum or cast bronze material.

(Not recommended for foot traffic areas.)

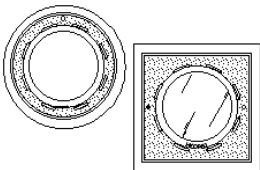

STAINLESS STEEL or BRONZE TRIM RINGS — BTR, BTS, STR, STS

A decorative escutcheon used when a high finish look is wanted. For finishing marble, tile or other installations. Available in round or square. Door is flush with escutcheon. Not available on SS doors.



LEXAN DOME — LC

A Lexan protective cover for use in areas where loose debris such as leaves and pine needles accumulate.

SPECIFICATIONS AND FEATURES

INTENDED USE: The M9700C LED incorporates a modular design with a water-tight module and junction box intended for applications with flow-through capability. The design of the housing starts at the rough-in sections with a molded junction box and holes at the bottom, allowing a pathway for the water to flow through the housing and drain out the bottom. This product is ideal for all outdoor uplight applications, such as wall washing and feature accentuation.

DOOR MATERIAL: Cast aluminum, cast bronze or stainless steel. Available in round or square door trim. Finish is natural aluminum or bronze. Stainless steel door is brushed finish. Aluminum doors may be painted. See ordering guide.

ROUGH-IN SECTION: Injection molded polymer with integral junction box for thru-branch wiring. The housing is U.V. stabilized, impact and corrosion resistant for use in all types of environments. The rough-in houses the LED and power module components and top door finishing section. Potting compound (PC21) recommended for junction box splices. PC21 sold separately.

CONDUIT ENTRIES: Two (2) bottom or side entries available. Box suitable for through-branch wiring. Splicing volume is 25 in³ (410 ccm)

FINISHING SECTION: Double lens design includes door assembly with 360° Aim-Lock™ module support and tilt ring that allows 15° of aiming. Active optical lenses are also available. Module indexing provides easy maintenance without re-aiming. Door trim locks into position with two stainless steel captive, tamper-resistant fasteners.

LED MODULE: Stainless steel housing, factory-sealed and purged of all moisture for longer component life. The LED module is suspended below the top door lens in a surface adjustable, 15° tilt mechanism. Lens is sealed with silicone gasket and stainless steel clamp band assembly with single fastener. Electrical connection to LED module is done through a submersible quick disconnect plug connector with gold-plated contacts.

LIGHT ENGINE: Light engines consist of chip-on-board (COB) LEDs directly coupled to the housing to maximize heat dissipation and promote long life (100,000 hrs, L92). Heat generated by LEDs is dissipated into and through the fixture housing, and adds less than 15°C to steady state operating lens temperature. For example, in a typical 25°C (77°F) operating environment, lens temperature would not exceed 40°C (104°F). All within 3 MacAdam ellipses

POWER MODULE: LED driver is encapsulated in a custom heat-dissipating epoxy resin that eliminates all moisture intrusion. Module is provided with submersible rated cord leads for connection to integral junction box and LED module.

ELECTRICAL: MVOLT (120-277) 50/60 Hz LED power supply. Class 1 electronic driver has a power factor >90%, THD <20%, and has an expected life of 100,000 hours with <1% failure rate. Surge protection meets a minimum Category C Low operation (per ANSI/IEEE C62.41.2).

LISTING: cCSAus, suitable for wet locations, laboratory tests conducted by CSA to UL Standard UL-1598 and UL-8750.

GOVERNMENT PROCUREMENT

BAA – Buy America(n) Act: Product qualifies as a domestic end product under the Buy American Act as implemented in the FAR and DFARS. Product also qualifies as manufactured in the United States under DOT Buy America regulations.

BABA – Build America Buy America: Product qualifies as produced in the United States under the definitions of the Build America, Buy America Act. Please refer to www.acuitybrands.com/resources/buy-american for additional information.

WARRANTY: 5-year limited warranty. This is the only warranty provided and no other statements in this specification sheet create any warranty of any kind. All other express and implied warranties are disclaimed. Complete warranty terms located at: www.acuitybrands.com/support/warranty/terms-and-conditions

Consult factory for details.

NOTE: Actual performance may differ as a result of end-user environment and application. All values are design or typical values, measured under laboratory conditions at 25 °C. Specifications subject to change without notice.

L2: Pole Light

Installed in Ground. No contact with building.
Planters will be filled with concrete to create
pad for pole light. Lighting design has been
selected to match street lights on City Street.

Location noted on Site Plan.

Lamp Posts were originally in this location:



Project: _____

Fixture Type: _____ Quantity: _____

Customer: _____

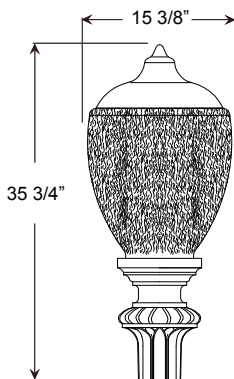

Specifications



Fitter:
Fitter is durable 356 cast aluminum.
All hardware provided shall be stainless steel or zinc plated steel.

Acorn Globe:
Acorn Globes available in clear stipple.

Fixture Mounting:
Post Mount: Post Cap with set screws.
Fits 3" and 4" poles.

Drivers:
Universal voltage 120-277 is standard. 0-10V dimming is standard for LED platforms.

See page 2 table for LED engine and driver specs, Voltage and dimming protocols

Electrical:
Approximately 12" of pull wire extends from luminaire. Additional pull wire provided for post mount arms and wall mounts.

Finish:
A polyester powder coat high quality finish is electro-statically applied and baked at 430° for exceptional durability and color retention. Products undergo an intensive five-step cleansing and pretreatment process for maximum paint adhesion.

Upper LED ring/band is painted #56 Silver,

Marine grade finish provides superior salt, humidity and UV protection. This coating withstands up to 3000 hours of continuous salt spray, comes with a 5-year warranty and is available in either a textured or gloss surface.

Modifications:
Consult factory for custom or modified designs.

LF0944

Weight: 23.5 lbs

EPA: 1.83

LED

Catalog Logic

LF0944 | 12 | CL | CPM78W30 | T5 | 40K- | PC | - | FIN02 | - | WM2141 | - | 72

Luminaire Series | Cage | Lens | Light Source & Wattage | Optic | CCT | Accessories | Finial | Mounting | Finish

Catalog Number

1 2 3 4 5 6 7 8 9

LF0944

1 OPTIONAL CAGES

See Page 3 for Style/Design

11, 12, 13, 14, 15
21, 22, 23, 24, 25
31, 32, 33, 34, 35
41, 42, 43, 44, 45

2 LENS

CL (Clear Stipple Polycarbonate)
WH (White Stipple Polycarbonate)

3 LIGHT SOURCE & WATTAGES

CPS30W18 (30W Ceramic LED)
CPS46W18 (46W Ceramic LED)
CPM78W30 (78W Ceramic LED)
CPM90W36 (90W Ceramic LED)

4 OPTICS

T2 (Type II)
T3 (Type III)
T4 (Type IV)
T5 (Type V)

5 COLOR TEMPERATURE (CCT)

27K (2700K)
30K (3000K)
35K (3500K)
40K (4000K)

6 ACCESSORIES

HSS90 (90° House Side Shield, polished)
HSS120 (120° House Side Shield, polished)
PHSS90 (90° House Side/Uplight Shield, polished)
PHSS120 (120° House Side/Uplight Shield, polished)
*EMG-LED20HV (20w, High Voltage LED Emergency Driver, remote placement, for use with Platforms, 78w or less)
HLMSPC-06 (High-Low Motion Sensor/Photocell; 15" - 30" Sensor Mounting Height)
HLMSPC-10 (High-Low Motion Sensor/Photocell; 8" - 15" Sensor Mounting Height)
PC (Button Photo Cell)
RNR (Reinforcing Neck Ring)
SP (Surge Protector, 10kA & 10kV)
TLPC (Twist Lock photo cell, includes receptacle & photo cell)
TL5 (5-pin Twist Lock receptacle)
TL7 (7-pin Twist Lock receptacle)

*For Emergency lumen output data, see Resources section at www.ANPlighting.com.

7 OPTIONAL FINIALS

See Page 3 for Style/Size

FIN02, FIN04, FIN05, FIN06, FIN10, FIN12, FIN15,
FIN18, FIN28, FIN39, FIN41, FIN42, FIN48, FIN64,
FIN70

8 MOUNTING SOURCE

Post Mount Arms *See Page 4 for Style/Size		Wall Mount Arms *See Page 4 for Style/Size	
PA5151	PA8711	WM2141	WM8581
PA5171	PA8831	WM2211	WM8831
PA5411		WM3351	
PA5621		WM4511	
PA5651		WM5131	
PA6211		WM5161	
PA7911		WM5311	
PA8031		WM5601	
PA8521		WM7411	
PA8571		WM8011	
Column Mount *See Page 4 for Style/Size			
CM	Column Mount		

9 FINISHES

*Premium and Marine Grade Finish have additional charges

Standard Colors	Standard Grade	Marine Grade*	Standard Colors	Standard Grade	Marine Grade*
Aspen Green	10	10M	Architectural Bronze	51	51M
Cantaloupe	11	11M	Patina Verde	52	52M
Lilac	12	12M	Copper Clay	53	53M
Putty	13	13M	Silver	56	56M
Raw Unfinished	40	NA	Black Verde	61	61M
Black	41	41M	Painted Chrome	70	70M
Forest Green	42	42M	Painted Copper	71	71M
Bright Red	43	43M	Textured Black	72	72M
White	44	44M	Matte Black	73	73M
Bright Blue	45	45M	Textured Architectural Bronze	76	76M
Sunny Yellow	46	46M	Textured White	77	77M
Aqua Green	47	47M	Textured Silver	78	78M
Galvanized	49	NA	PREMIUM FINISH	Premium Grade*	Marine Grade*
Navy	50	50M	Carbon Graphite	96	96M

Consult Factory for additional paint charges and availability.

Project: _____
 Fixture Type: _____ Quantity: _____
 Customer: _____

LED PERFORMANCE

CERAMIC PLATFORM

System Wattage (Nominal)	CCT	CRI	Type II					Type III					Type IV					Type V				
			Typical Luminous Flux	Lumens Per Watt	B	U	G	Typical Luminous Flux	Lumens Per Watt	B	U	G	Typical Luminous Flux	Lumens Per Watt	B	U	G	Typical Luminous Flux	Lumens Per Watt	B	U	G
30W	2700K	70	3138	105	1	3	1	2981	99	1	3	1	3172	106	1	3	1	3289	110	2	3	1
	3000K	70	3274	109	1	3	1	3111	104	1	3	1	3310	110	1	0	1	3432	114	2	3	1
	3500K	70	3182	106	1	3	1	3024	101	1	3	1	3218	107	1	3	1	3335	111	2	3	1
	4000K	70	3433	114	1	0	1	3262	109	1	3	1	3471	116	1	3	1	3598	120	2	3	1
46W	2700K	70	4811	105	2	3	2	4571	99	2	3	2	4864	106	2	3	2	5042	110	3	3	2
	3000K	70	5020	109	2	3	2	4770	104	2	3	2	5076	110	2	3	2	5262	114	3	3	2
	3500K	70	4879	106	2	3	2	4636	101	2	3	2	4934	107	2	3	2	5114	111	3	3	2
	4000K	70	5264	114	2	3	2	5002	109	2	3	2	5323	116	2	3	2	5517	120	3	3	2
78W	2700K	70	8195	105	2	3	2	8255	106	2	3	2	8530	109	3	3	3	9044	116	3	3	3
	3000K	70	8552	110	2	3	2	8614	110	2	3	2	8902	114	3	3	3	9438	121	3	3	3
	3500K	70	8312	107	2	3	2	8372	107	2	3	2	8652	111	3	3	3	9173	118	3	3	3
	4000K	70	8968	115	2	3	2	9033	116	2	3	2	9334	120	3	3	3	9896	127	3	3	3
90W	2700K	70	9413	105	3	3	3	8944	99	3	3	3	9517	106	3	3	3	9866	110	3	3	3
	3000K	70	9822	109	3	3	3	9333	104	3	3	3	9931	110	3	3	3	10295	114	3	3	3
	3500K	70	9547	106	3	3	3	9071	101	3	3	3	9653	107	3	3	3	10006	111	3	3	3
	4000K	70	10300	114	3	3	3	9786	109	3	3	3	10414	116	3	3	3	10795	120	3	3	3

LED SPECIFICATIONS - CERAMIC PLATFORM

- Performance, Ceramic-cooling technology
- Up to 10,795 lumens
- Efficacy ranges from 99-120 lm/W
- Distributions: Types II, III, IV, V
- CCT: 2700K, 3000K, 3500K, 4000K
- Life: L70 > 50,000 hours
- Ingress Protection: IP66
- Certification: ETL
- CRI: >70

WARRANTY

See www.ANPlighting.com for complete fixture warranty.

- 5 year limited warranty* on Platform LED engines
- 5 year limited warranty* on Platform Drivers

*Limited Warranty: A typical year is defined as 4380 hours of operation. Failure defined as more than 10% of the total platform LED's not operating

DRIVER SPECIFICATION

- Universal Input 120-277V
- 0-10V Dimming to 10%
- Power Factor @ Full Load >95%
- THD @ Full Load <10%
- Constant current output 50/60Hz
- Operating Temperature: -40°C Minimum
- Ingress Protection: IP66
- Certifications: UL Recognized, CSA, RoHS

SURGE PROTECTION

- A Surge Protection Device (SPD) is standard featuring a 20kA maximum discharge current 8/20µs Waveform (Imax); 10kA nominal discharge current 8/20µs Waveform (In) and thermally protected varistor technology.
- Meets IEEE C62.41.2 Location Category C High and US Dept of Energy MSSLC Model Spec.
- SPD shall be wired in series and will result in an open circuit during a fault state, resulting in the luminaire to turn off to protect system components thereby indicating SPD module replacement.

ACCESSORIES



HSS90 & HSS120



PHSS90 & PHSS120



EMG-LED 20HV



HLMSPC-06 & HLMSPC-10



PC



RNR



TLPC



TL5 & TL7

Project: _____
 Fixture Type: _____ Quantity: _____
 Customer: _____

CAGES



FINIALS

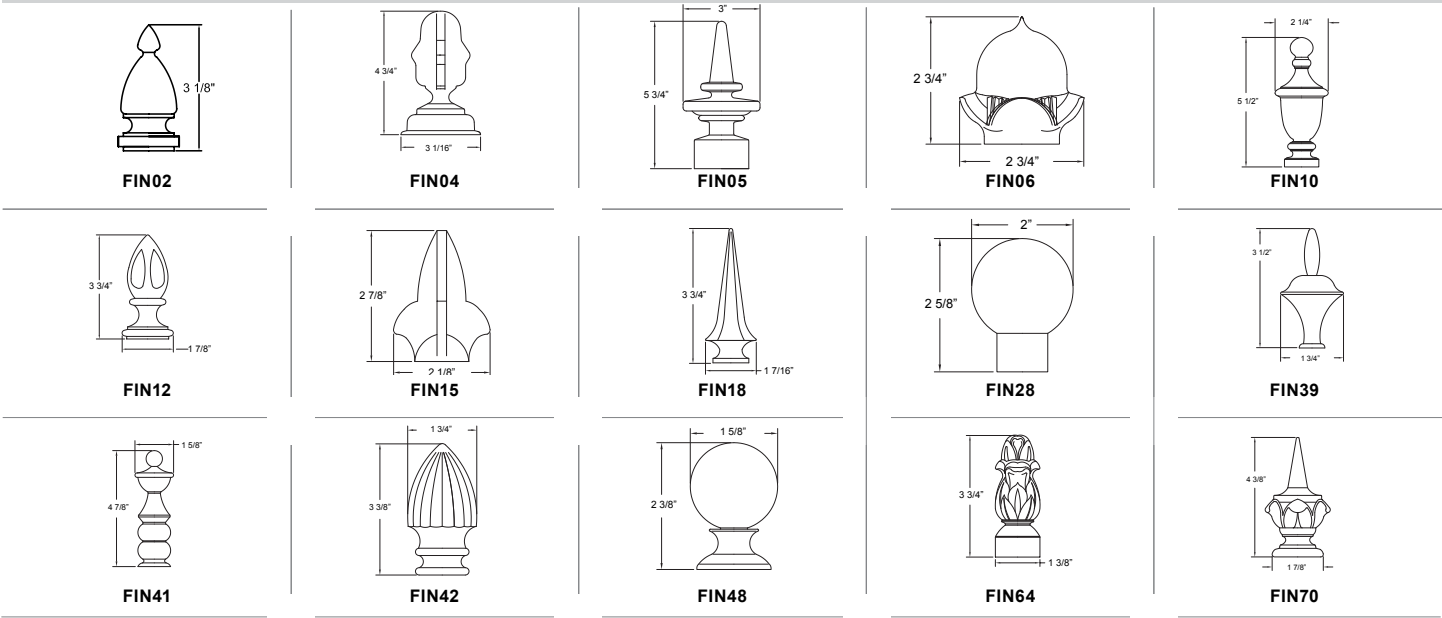

Project: _____
 Fixture Type: _____ Quantity: _____
 Customer: _____

POST MOUNTS - See Post Arm Section on Website for Specification Sheets and additional post arms.
 Dimensions are Projection x Height

COLUMN MOUNT

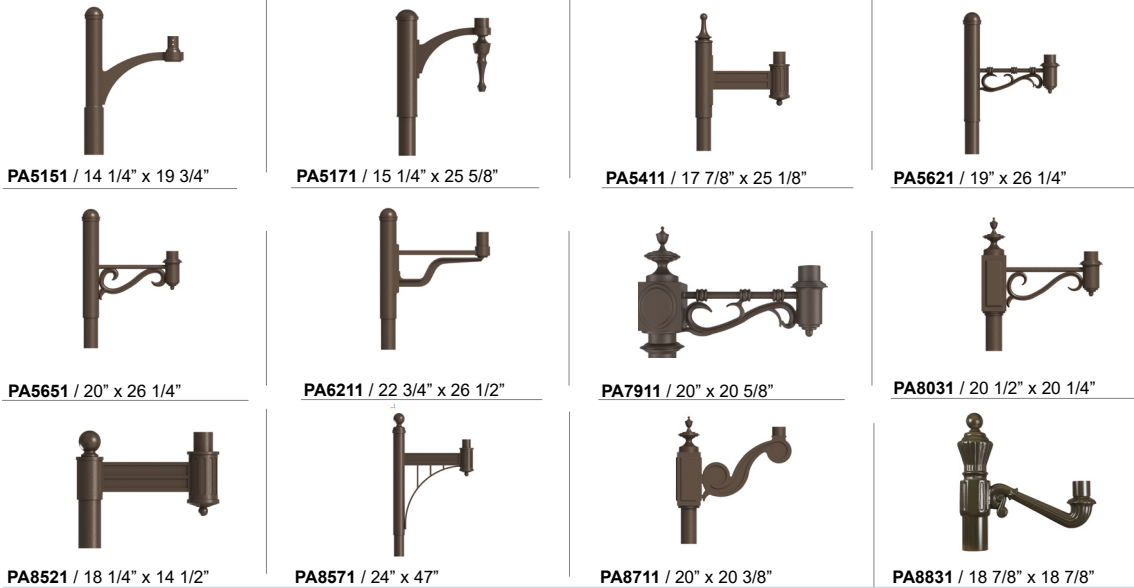

WALL MOUNTS - See Wall Mount Section on Website for Specification Sheets and additional wall mount arms.
 Dimensions are Projection x Height.

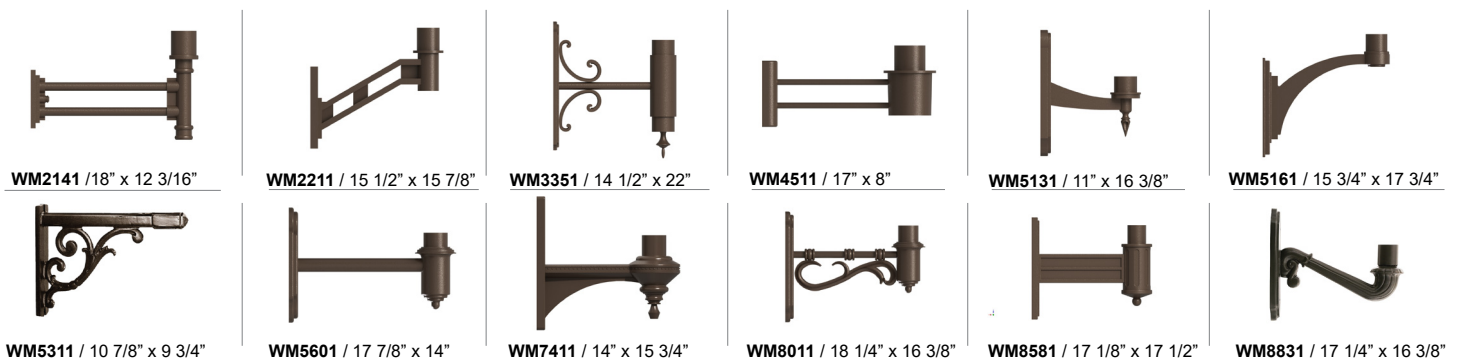

ITEM	QTY	PART NUMBER	DESCRIPTION
1	2	108911	Decorative Base Half
2	4	44964-043	HHCS, 3/8-16UNC x 1-1/2; S.S.

REV	DESCRIPTION	ZONE	DATE	AUTHOR

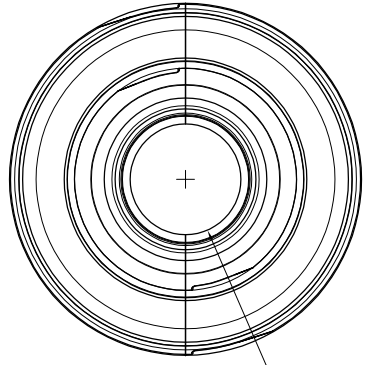

Versions			
Part Number	Dia. 'A'	Height 'B'	
108912-001	7.5	60.75	
108912-002	8.125	60.25	

.500
CUT LINE FOR
-002 VERSION

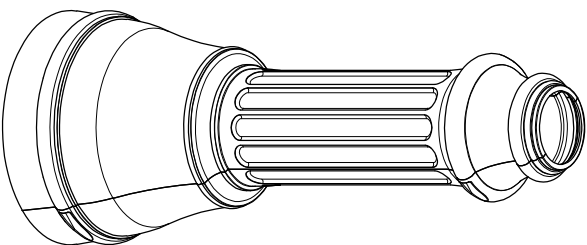
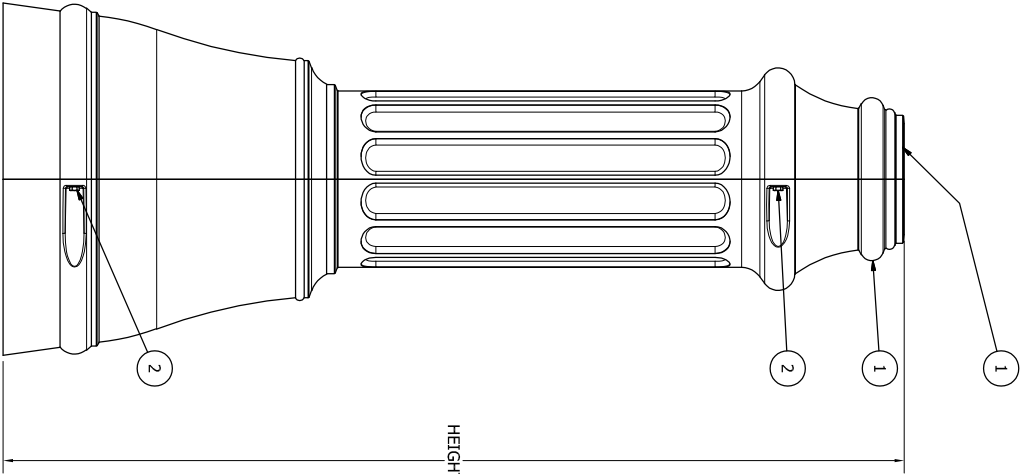
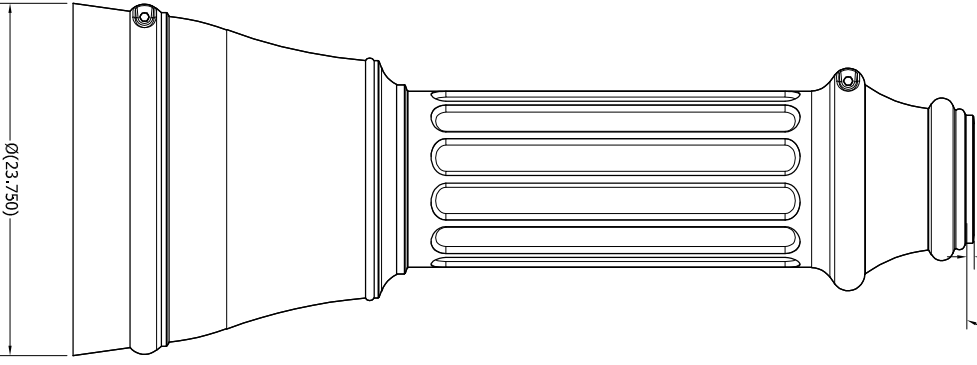

DRAWN pgaskins		Hapco Arlington, VA	
6/15/2022		TITLE Decorative Clamshell Base Assy.	
Est Wgt: 93.1 lbmass		SIZE C	DWG NO 108912
Dims are in Inches		SCALE	REV

A

B

C

D

2

2

3

3

4

4

A

B

C

D

1

1

SHEET 1 OF 1

L3: LED Accent Lighting

Installed to accent Top Cornice.
Not Visible From Street.

Location noted on Building Elevations.

Small aluminum channel is installed with small screws along back side of cornice.



FIXTURE TYPE _____

PROJECT NAME _____

LOCATION _____

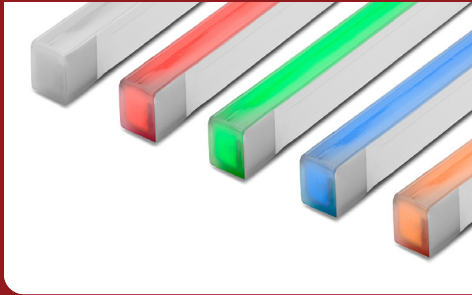

Signwave® 3 Silicone

NARROW VIEW FLEXIBLE LIGHTING SYSTEM



I Description

Signwave 3 is the only series offered with Horizontal or Vertical bending options. The perfectly flat top of Signwave 3 provides greatly reduced side-viewing angles and concentrates the incredibly bright illumination onto a single direct-view surface.

I Features

- Dimmable
- 50,000 Hour Life
- Flat Profile for Streamline Projects
- Horizontal or Vertical Bending Option
- IP68
- UL-Listed for Indoor and Outdoor Use
- Factory-Installed Power Feed
- Injection-Molded Flush End Caps
- For Use with 24V Power Supplies

I Dimensions

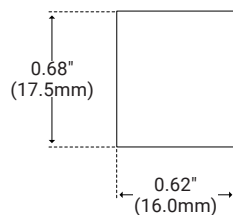

I Specifications

Series	SW3S
Temp/Color	Static White, Red, Green, Blue, Amber, RGBW, DW (1800K–3000K), CT
Input Voltage	24V DC
Lumens per Foot	143 lm/ft (Static White)
Watts per Foot	2.4–3.7*
Beam Angle	160°
CRI	80+
Max Run Length	Unlimited*
Dimensions	0.62" (16.0mm) × 0.68" (17.0mm)
Dimming Options	PWM, Triac, 0–10V, DMX, Hi-lume
Operating Temp	-40°F (-40°C) to 131°F (55°C)

I Bending Options

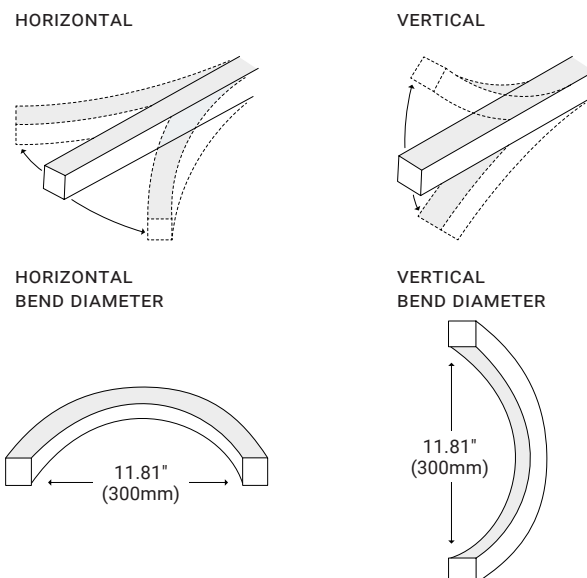

* See Series Data for more information

Product Code Builder

Series	Length	Temp/Color	Bending
SW3S	xx.xx		
SW3S – Signwave 3 Silicone	xx.xx – Length (in)	27K – 2700K 30K – 3000K 35K – 3500K 40K – 4000K 57K – 5700K RD – Red GRN – Green BL – Blue AM – Amber RGBW – Color Changing DW – Dim to Warm CT – Color Tuning	VR – Vertical HZ – Horizontal
Feed Point	Feed Length	Rating	
	S	IP68	
B – Bottom Feed SL – Side-Feed Left SR – Side-Feed Right E – End Feed	S – Standard (118") xx.xx – Length (in)	IP68 – IP68 Rated	

Example: SW3S-36-27K-VR-B-S-IP68

Series Data

	Static White (Specify CCT)	Red	Green	Blue	Amber	RGBW	DW (18K–30K)	CT (22K–57K)
Wavelength (nm)	N/A	620–630	520–530	465–475	585–595	N/A	N/A	N/A
Wattage (W/ft)	3.7	2.4	3.7	3.7	2.4	4.6	3.7	3.65
Power Feed (ft)	Every 26ft	Every 38ft	Every 26ft	Every 26ft	Every 38ft	Every 25ft	Every 26ft	Every 22ft
Production Intervals (in)	2.19"	3.25"	2.19"	2.19"	3.25"	3.25"	2.46"	3.28"

Ferrule

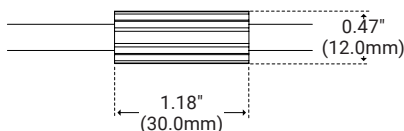

DryWire ferrule located 4.53" (± 0.39 ") from the cable connector. Protects against damage from water ingress inside cable wire. Please note that any attempt to remove the anti-wicking ferrule will result in the voiding of the warranty.

Feed Locations

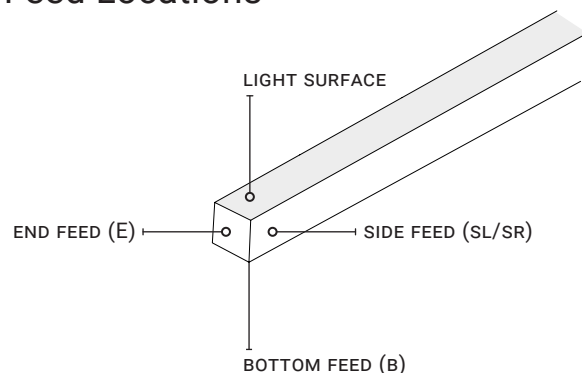

I Feed Options

Bottom Feed (IP68)‡



Unit Number	B
Unit Width	0.63" (16.0mm)
Unit Height	1.18" (29.9mm)

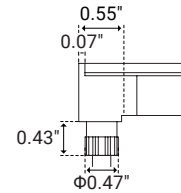
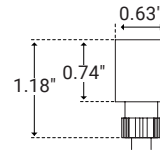

Side Feed Right/Left (IP68)‡

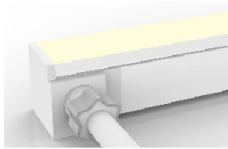

Unit Number	SL/SR
Unit Width	0.70" (2.75mm)
Unit Height	0.74" (2.91mm)

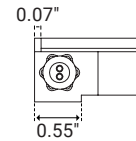
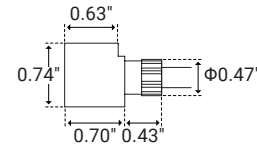

End Feed (IP68)‡

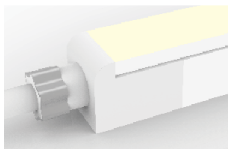

Unit Number	E
Unit Width	0.62" (15.7mm)
Unit Height	0.66" (16.7mm)

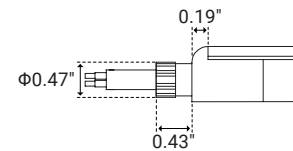
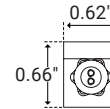

I End Cap

End Cap (IP68)

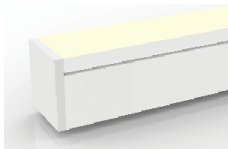

Unit Number	EC
Unit Width	0.62" (15.7mm)
Unit Height	0.66" (16.7mm)

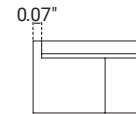
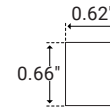

‡ Ferrule not included. The provided drawings and images are intended solely as a visual reference and does not fully depict the final product.

I Accessories

Aluminum Serrated Channel



Unit Number	SW-K-AL-CH-SR-2M
Material	Aluminum
Length	78.75" (2m)
Width	0.80" (20.2mm)
Height	0.82" (20.8mm)
Internal Width	0.64" (16.3mm)

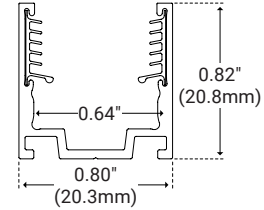

Aluminum Serrated Clip



Unit Number	SW-K-CLP-AL-SR
Material	Aluminum
Length	0.79" (20.0mm)
Width	0.80" (20.2mm)
Height	0.82" (20.8mm)
Internal Width	0.64" (16.8mm)

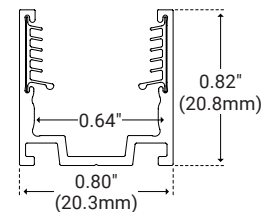

Aluminum Serrated Flex Channel



Unit Number	SW-K-CH-AL-FLX-1M
Material	Aluminum
Length	39.30" (1m)
Width	0.80" (20.2mm)
Height	0.82" (20.8mm)
Internal Width	0.64" (16.3mm)

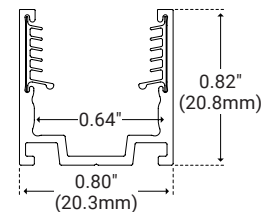

Plastic Channel

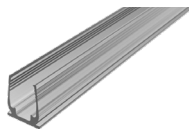

Unit Number	SW-K-CH-PL-2M
Material	Plastic
Length	78.75" (2m)
Width	0.79" (20.0mm)
Height	0.92" (23.5mm)
Internal Width	0.35" (8.9mm)

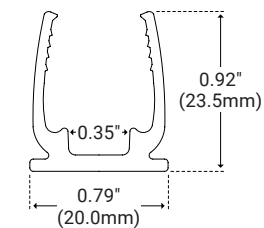

Side Mounting Bracket



Unit Number	SW-CLP-RA
Material	Aluminum
Length	0.78" (20.0mm)
Width	0.98" (25.0mm)
Height	2.75" (70.0mm)

Must be paired with channel

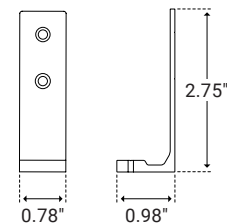

L4: Entry Lighting

Installed in ceiling of Entry to replace existing lighting. Ceiling is not a historic material.

Location noted on Building Elevations.



Catalog Number	Attachment C.44
Notes	
Type	

FEATURES & SPECIFICATIONS

INTENDED USE — Typical applications include corridors, lobbies, conference rooms and private offices.

CONSTRUCTION — Retrofit, remodel, and new construction mounting types. See table for compatible ceiling openings and thickness range.

Optional goof rings available for additional overlap trim coverage.

1/2"-1-1/2" ceiling thickness

25° ambient temperature

IC rated up to 1000lm

OPTICS — 55° cutoff

New construction frame accessories approved for 8 (4 in/4 out) No. 12 AWG conductors rated for 90°C through wiring.

1.0 S/MH standard (wallwash reflector available)

80CRI standard (90CRI optional)

ELECTRICAL — Adjustable lumen output with three module options. Fixed lumen options also available. MVOLT 120/277V 50/60Hz driver (0-10V & 120V Phase Dimming to 10% min dimming level)

100LPW typical

FCC CFR Title 47 Part 15 Class A for lower lumen range. FCC CFR Title 47 Part 15 Class B for higher lumen range.

L80 at 60,000 hours

3 SDCM

LISTINGS — Certified to US and Canadian safety standards. Damp location standard (Wet location, covered ceiling optional). Some configurations are ENERGY STAR® certified, please visit www.energystar.gov for specific products. TAA compliant.

WARRANTY — 5-year limited warranty. Complete warranty terms located at:

www.acuitybrands.com/support/customer-support/terms-and-conditions

Note: Actual performance may differ as a result of end-user environment and application.

All values are design or typical values, measured under laboratory conditions at 25 °C.

Specifications subject to change without notice.



A+ Capable options indicated by this color background.



LBR

**4'-8" OPEN
Retrofit Downlight**



ORDERING INFORMATION

Lead times will vary depending on options selected. Consult with your sales representative.

Example: LBR6 ALO2 SWW1 AR LSS MWD MVOLT UGZ 90CRI

Series	Lumens ¹	Color temperature ¹	Reflector Color	Reflector Flange	Reflector Finish
LBR4 4" Retrofit	Adjustable Lumen Output	Switchable CCT	AR Clear	(blank) Self-flanged	LSS Semi-specular
LBR6 6" Retrofit	ALO1 500/750/1000lm	SWW1 3000K-3500K-4000K-5000K	WR ² White painted	TRW ³ White painted flange	
LBR8 8" Retrofit	ALO2 1000/1500/2000lm	Fixed CCT	BR ² Black painted	TRBL ⁴ Black painted flange	
LBR4WW 4" Retrofit Wallwash	ALO3 2000/2500/3000lm	30K 3000K			
LBR6WW 6" Retrofit Wallwash	Fixed Lumen Output	35K 3500K			
LBR8WW 8" Retrofit Wallwash	05LM 500lm	40K 4000K			
	07LM 750lm	50K 5000K			
	10LM 1000lm				
	15LM 1500lm				
	20LM 2000lm				
	25LM 2500lm				
	30LM 3000lm				

Distribution	Voltage	Driver	Options
MWD Medium wide (1.0 s/mh)	MVOLT 120V - 277V	UGZ Universal dimming to 10% 0-10V; line voltage dimming (120V)	90CRI High CRI (90+) AT ⁷ Airtight E10WCPR ⁸ Batterypack (10W constant power) T20 Compliant remote test switch
WW ⁵ Wallwash		DALI ⁶ DALI dimming to 1%	ELR ⁸ Batterypack (10W constant power) Non-T20 Compliant remote test switch EC1 ⁹ Extended Conduit (18") EC6 ⁹ Extended Conduit (6ft) WL ⁷ Wet Location QDS ¹⁰ Quick disconnect plugs

Notes

- Fixed CCT and lumens must be specified together (for example: 10LM 30K).
- Not available with reflector finish.
- For use with Clear (AR) reflector finish only. Not applicable with WR (white reflector).
- For use with Clear (AR) reflector finish only. Not applicable with BR (Black reflector).
- Only available with WW Series (for example LBR4WW).
- Not available with Fixed CCT and lumens.
- Not available with wallwash (WW).
- Top access installation or 17.5" plenum clearance required for roomside installation
- Not available with QDS, ELR and E10WCPR.
- QDS not available with emergency battery packs.
- Field installed. Top access installation required.

Accessories: Order as separate catalog number. Shipped separately.	
LBRGR56	Goof ring 5-3/4" to 6-3/4"
LBRGR78	Goof ring 7-3/4" to 8-3/4"
LBRGR 910	Goof ring 9-3/4" to 10-3/4"
LBR468 FPAN U	Mounting plate 4"-8" unit pack
LBR468 FPAN J10	Mounting plate 4"-8" 10-pack
LBR4PF	4" New construction frame with JBOX
LBR6PF	6" New construction frame with JBOX
LBR8PF	8" New construction frame with JBOX
LBR4PFW	4" New construction frame with JBOX, 18" conduit
LBR6PFW	6" New construction frame with JBOX, 18" conduit
LBR8PFW	8" New construction frame with JBOX, 18" conduit
LBR4PFWQDS	4" New construction frame with JBOX, 18" conduit, quick disconnects
LBR6PFWQDS	6" New construction frame with JBOX, 18" conduit, quick disconnects
LBR8PFWQDS	8" New construction frame with JBOX, 18" conduit, quick disconnects
LBR SDT 347V 75W ASM	Field installed 347V Step-down transformer
NPP16 D EFP ¹¹	Field installed nLight Power Pack

Series	Plaster Frame Accessory	Compatible Mounting Option
LBR4, LBR4WW	LBR4PF	QDS, EC1, ELR, E10WCPR
	LBR4PFW	Base fixture only
	LBR4PFWQDS	QDS fixture only
LBR6, LBR6WW	LBR6PF	QDS, EC1, ELR, E10WCPR
	LBR6PFW	Base fixture only
	LBR6PFWQDS	QDS fixture only
LBR8, LBR8WW	LBR8PF	QDS, EC1, ELR, E10WCPR
	LBR8PFW	Base fixture only
	LBR8PFWQDS	QDS fixture only

Goof rings must specify finish
 Examples: LBRGR56 WR, LBRGR78 BR, LBRGR910 AR
 WR = white, BR = black, AR = Clear

* All dimensions are inches (millimeters) unless otherwise noted.

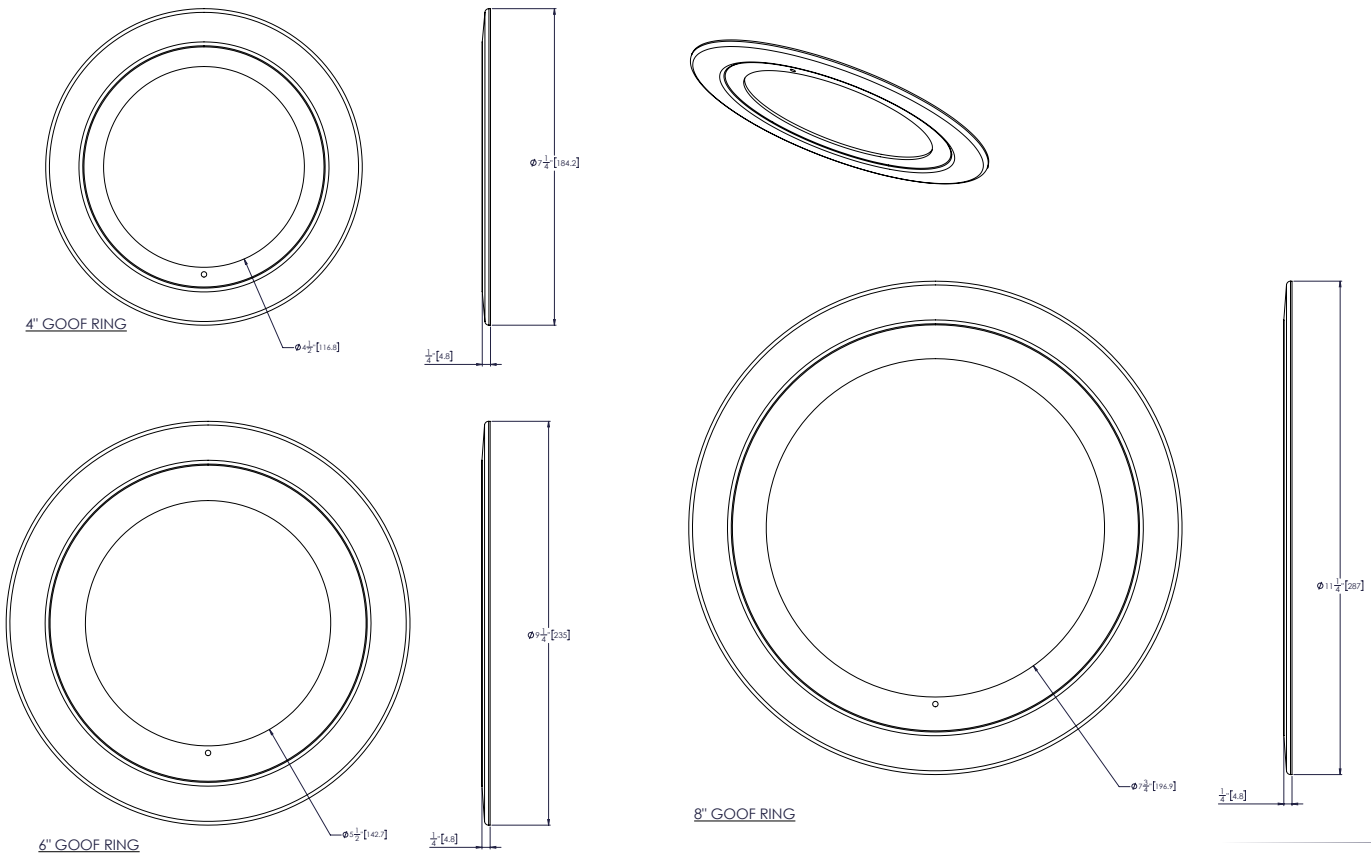

* All dimensions are inches (millimeters) unless otherwise noted.

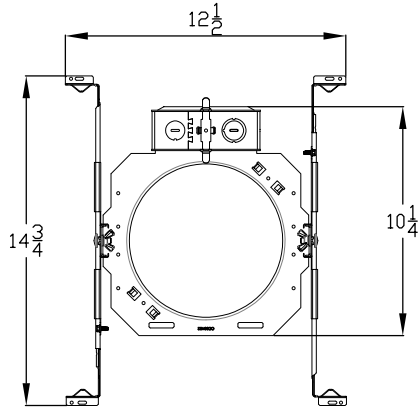
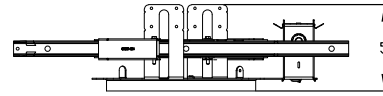
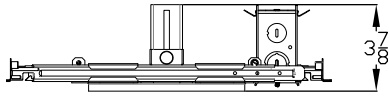

4" & 6" New Construction Frame

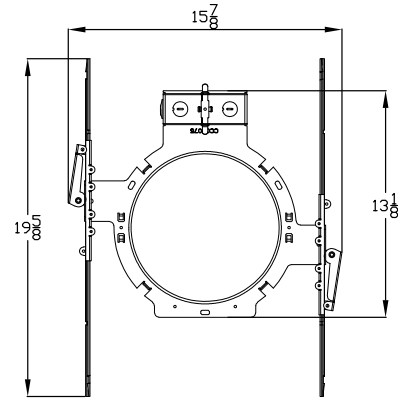

8" New Construction Frame

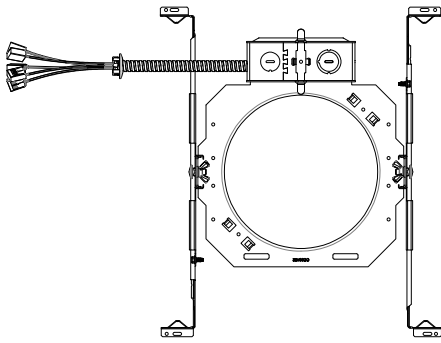

4" & 6" New Construction Frame, 18" conduit

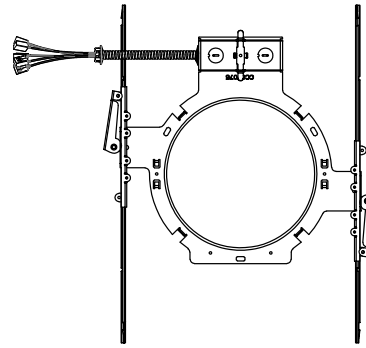

8" New Construction Frame, 18" Conduit

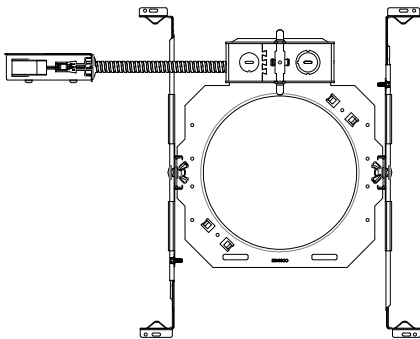

4" & 6" New Construction Frame, QDS

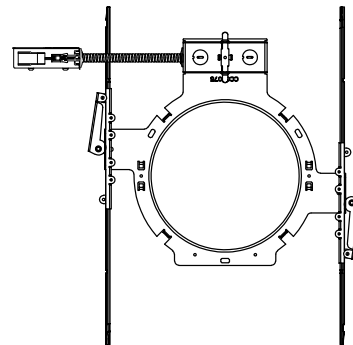

8" New Construction Frame, QDS

Aperture Size	Ceiling Cutout
4 in	5-1/8"
6 in	7-1/8"
8 in	8-3/4"

* All dimensions are inches (millimeters) unless otherwise noted.

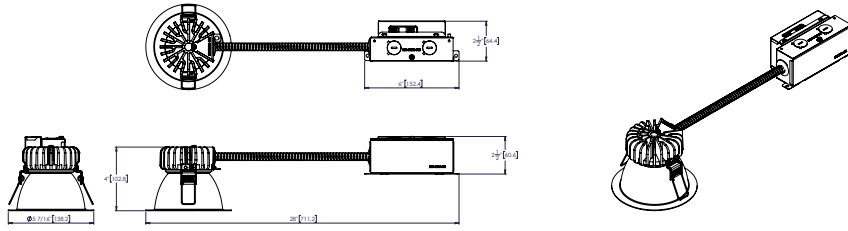

LBR4 SWW1 ALOx xx xxx MVOLT UGZ

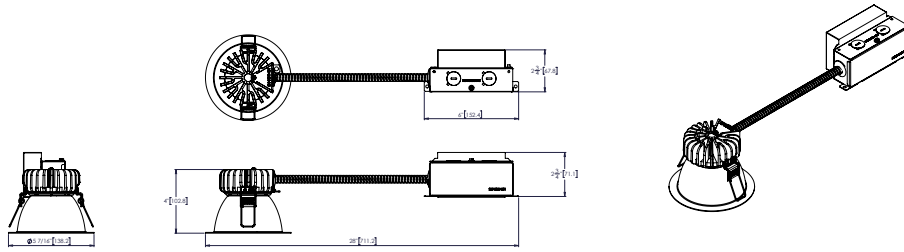

LBR4 SWW1 ALO1/2 xxx xxx MVOLT DALI

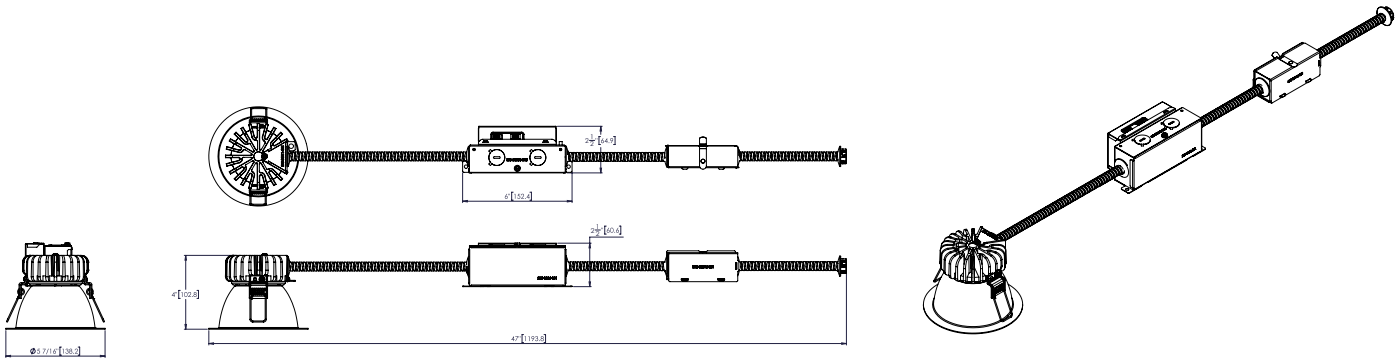

LBR4 SWW1 ALOx xx xxx MVOLT UGZ QDS

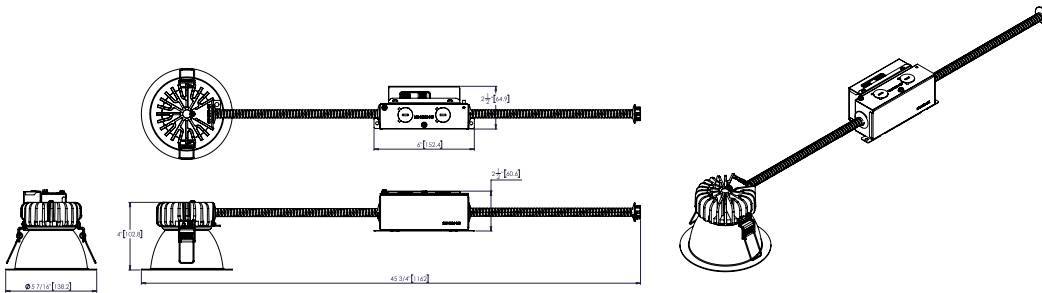

LBR4 SWW1 ALOx xx xxx MVOLT UGZ EC1

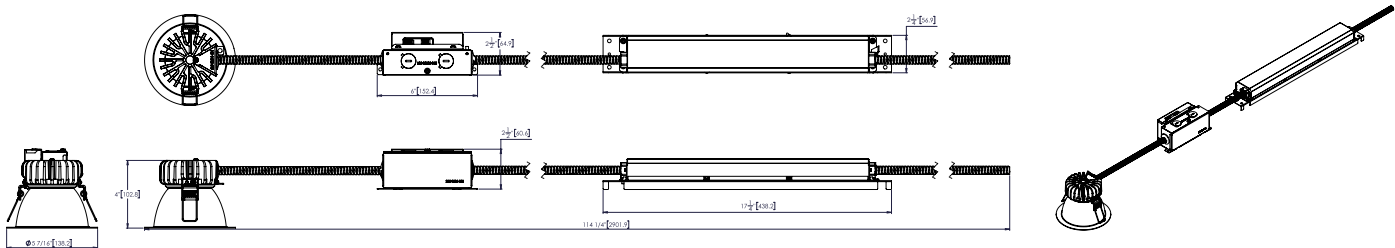

LBR4 SWW1 ALOx xx xxx MVOLT UGZ ELR

* All dimensions are inches (millimeters) unless otherwise noted.

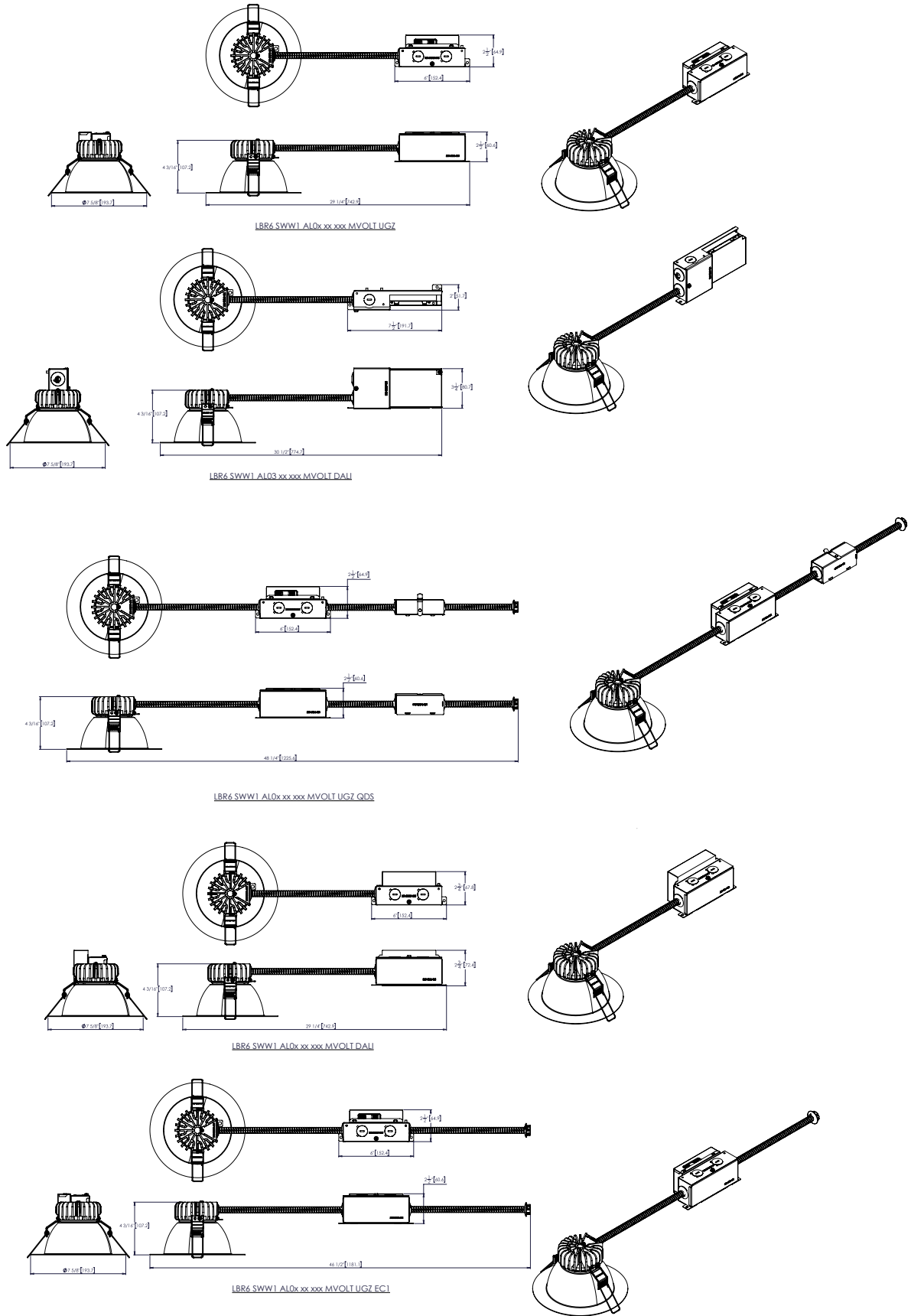

* All dimensions are inches (millimeters) unless otherwise noted.

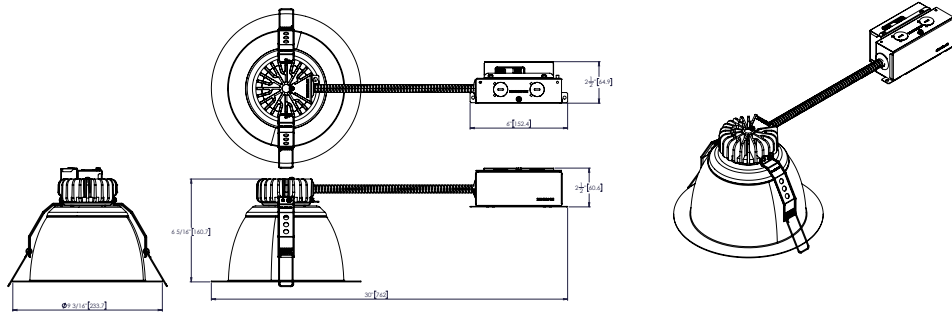

LBR8 SWW1 ALOx xx xxx MVOLT UG7

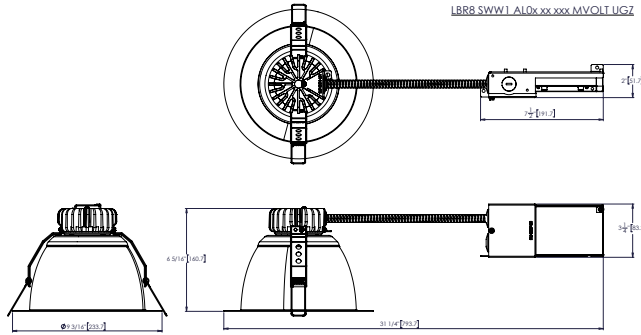

LBR8 SWW1 ALO3 xx xxx MVOLT DALI

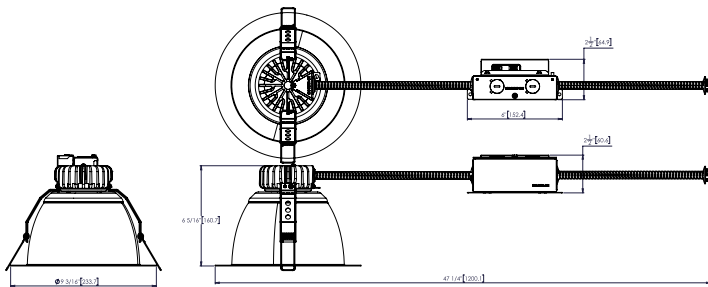

LBR8 SWW1 ALOx xx xxx MVOLT UG7 FC1

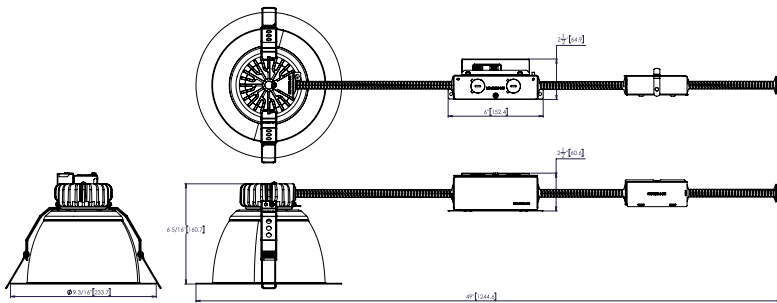

LBR8 SWW1 ALOx xx xxx MVOLT UG7 QDS

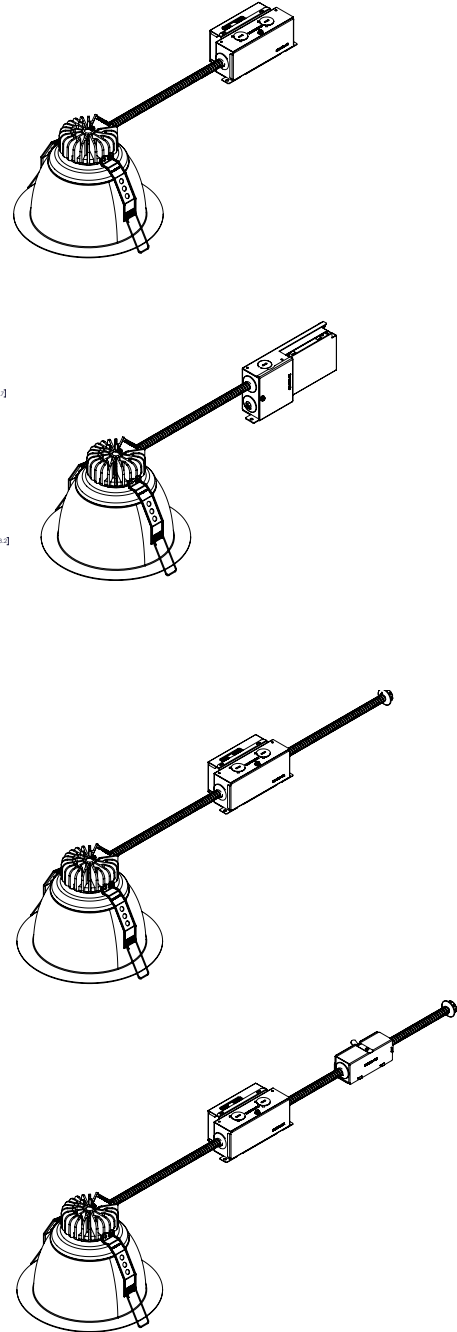

LUMEN OUTPUT MULTIPLIERS - CCT			
3000K	3500K	4000K	5000K
0.98	1.0	1.01	1.03

LUMEN OUTPUT MULTIPLIERS - FINISH	
Specular (LS)	1.00
White (WR)	1.03
Black (BR)	0.60

HOW TO ESTIMATE DELIVERED LUMENS IN EMERGENCY MODE

Use the formula below to estimate the delivered lumens in emergency mode

Delivered Lumens = 1.25 x P x LPW

P = Output power of emergency driver. P = 10W for PS1055CP

LPW = Lumen per watt rating of the luminaire. This information is available on the ABL luminaire spec sheet.

The LPW rating is also available at DesignLight Consortium.

PHOTOMETRY

Distribution Curve Distribution Data Output Data Coefficient of Utilization Illuminance Data at 30" Above Floor for a Single Luminaire

LBR4 SWW1 AL02 AR LSS MWD MVOLT UGZ, Input Watts: 18.1, Delivered Lumens: 1929, LPW: 106.6, S/MH: 0.98, Test No: 20-518-01

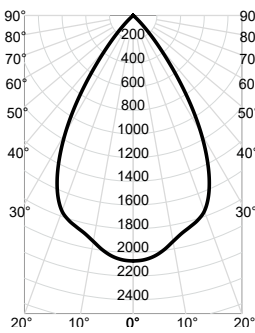

Table with columns: CP Summary, Zonal Lumen Summary, Coefficients of Utilization, Cone of Light, Luminescence (cd/sq.m). Includes rows for 0°, 5°, 15°, 25°, 35°, 45°, 55°, 65°, 75°, 85°, 90°.

LBR4WW SWW1 AL02 AR LSS WW MVOLT UGZ, Input Watts: 18.1, Delivered Lumens: 1922, LPW: 106.2, S/MH: 0.73, Test No: 20-518-02

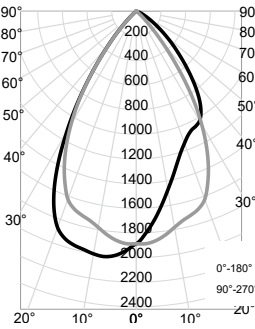

Table with columns: CP Summary, Zonal Lumen Summary, Coefficients of Utilization, Luminescence (cd/sq.m). Includes rows for 0°, 5°, 15°, 25°, 35°, 45°, 55°, 65°, 75°, 85°, 90°.

LBR6 SWW1 AL02 AR LSS MWD MVOLT UGZ, Input Watts: 18.1, Delivered Lumens: 1970, LPW: 108.8, S/MH: 0.94, Test No: 20-518-03

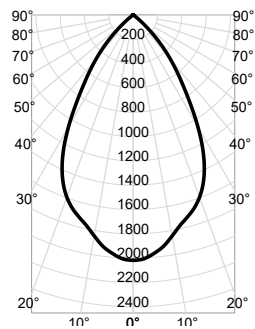

Table with columns: CP Summary, Zonal Lumen Summary, Coefficients of Utilization, Cone of Light, Luminescence (cd/sq.m). Includes rows for 0°, 5°, 15°, 25°, 35°, 45°, 55°, 65°, 75°, 85°, 90°.

LBR6WW SWW1 AL02 AR LSS WW, Input Watts: 18.7, Delivered Lumens: 1981, LPW: 105.9, S/MH: 0.67, Test No: 20-518-A1

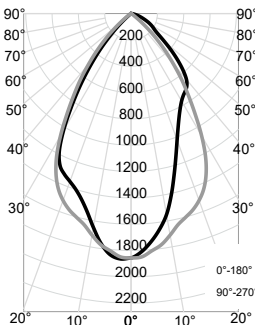
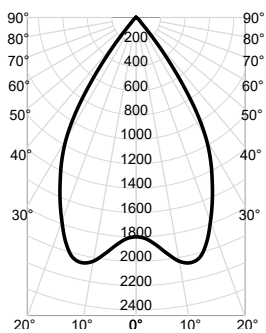

Table with columns: CP Summary, Zonal Lumen Summary, Coefficients of Utilization, Luminescence (cd/sq.m). Includes rows for 0°, 5°, 15°, 25°, 35°, 45°, 55°, 65°, 75°, 85°, 90°.

PHOTOMETRY

Distribution Curve Distribution Data Output Data Coefficient of Utilization Illuminance Data at 30" Above Floor for a Single Luminaire

LBR8 SWW1 ALO2 AR LSS MWD MVOLT UGZ, Input Watts: 18.1, Delivered Lumens: 1883, LPW: 104.0, S/MH: 1.05, Test No: 20-518-04



CP Summary				Zonal Lumen Summary				Coefficients of Utilization												Cone of Light			Luminaire (cd/sq.m)	
0°	Zone	Lumens	% Fixture	pw	80%				70%				50%				Mounting Height	Initial FC Center Beam	Beam Diameter	Average Luminaire				
					50%	30%	10%	50%	30%	10%	50%	30%	10%	50%	30%	10%				0°	85°			
0°	0° - 30°	1,416	75%	0	119	119	119	116	116	116	111	111	111	6.0	50.0	7.3	0°	68,479						
5°	0° - 40°	1,812	96%	1	111	109	106	109	107	105	105	103	101	8.0	28.1	9.7	45°	2,703						
15°	0° - 60°	1,878	100%	2	104	100	96	102	98	95	99	96	93	10.0	18.0	12.2	55°	1,062						
25°	0° - 90°	1,883	100%	3	97	92	88	95	91	87	93	89	86	12.0	12.5	14.6	65°	288						
35°	90° - 180°	0	0%	4	91	85	81	89	85	81	87	83	80	14.0	9.2	17.0	75°	191						
45°	0° - 180°	1,883	100%	5	85	79	75	84	79	75	82	78	74	Beam Angle: 62.6°		85°		131						
55°		16		6	80	74	70	79	74	70	78	73	69	Field Angle: 79.4°										
65°		3		7	75	69	65	75	69	65	73	68	65											
75°		1		8	71	65	61	70	65	61	69	64	61											
85°		0		9	67	61	57	67	61	57	66	61	57											
90°		0		10	64	58	54	63	58	54	62	57	54											

LBR8WW SWW1 ALO2 AR LSS WW, Input Watts: 18.7, Delivered Lumens: 1929, LPW: 103.2, S/MH: 0.88, Test No: 20-518-A2

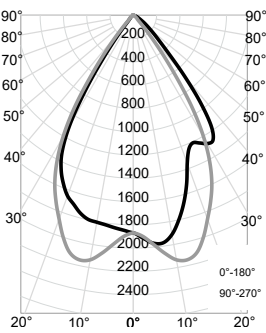

CP Summary				Zonal Lumen Summary				Coefficients of Utilization												Luminaire (cd/sq.m)	
0°	90°	Zone	Lumens	% Fixture	pw	80%				70%				50%				0°	Average Luminaire		
						50%	30%	10%	50%	30%	10%	50%	30%	10%	50%	30%	10%				
0°	1,869	1,869	0° - 30°	1,369	71%	0	119	119	119	116	116	116	111	111	111	45°	18,909				
5°	1,965	1,975	0° - 40°	1,794	93%	1	111	108	106	108	106	104	104	103	101	55°	7,969				
15°	1,672	2,110	0° - 60°	1,913	99%	2	103	99	95	101	97	94	98	95	92	65°	3,441				
25°	1,210	1,595	0° - 90°	1,929	100%	3	96	91	87	94	90	86	92	88	85	75°	1,511				
35°	1,170	625	90° - 180°	0	0%	4	89	84	80	88	83	79	86	82	78	85°	748				
45°	328	50	0° - 180°	1,929	100%	5	84	78	74	83	77	73	81	76	73						
55°	112	17				6	78	72	68	78	72	68	76	71	67						
65°	36	5				7	74	68	63	73	67	63	72	67	63						
75°	10	3				8	69	63	59	69	63	59	68	63	59						
85°	2	1				9	65	60	56	65	59	55	64	59	55						
90°	0	1				10	62	56	52	61	56	52	61	56	52						

LBR ROUND LUMEN TABLES

LBR4		80CRI									
Lumen Output	Wattage	30K/80CRI		35K/80CRI		40K/80CRI		50K/80CRI			
		Delivered Lumens	LPW	Delivered Lumens	LPW	Delivered Lumens	LPW	Delivered Lumens	LPW		
AL01 (500LM)	6	570	99.0	584	100.6	597	102.5	616	104.9		
AL01 (750LM)	9	903	101.6	924	103.2	946	105.1	975	107.6		
AL01 (1000LM)	13	1268	98.3	1297	99.8	1328	101.7	1369	104.1		
AL02 (1000LM)	13	1344	108.2	1375	110.0	1408	112.0	1451	114.6		
AL02 (1500LM)	19	1961	104.7	2007	106.4	2055	108.3	2118	110.9		
AL02 (2000LM)	25	2471	99.4	2528	101.0	2588	102.9	2668	105.3		
AL03 (2000LM)	25	2542	102.8	2601	104.5	2663	106.4	2745	108.9		
AL03 (2500LM)	32	3069	97.7	3140	99.3	3214	101.1	3314	103.5		
AL03 (3000LM)	38	3485	92.9	3566	94.4	3651	96.2	3764	98.4		

LBR4WW		80CRI									
Lumen Output	Wattage	30K/80CRI		35K/80CRI		40K/80CRI		50K/80CRI			
		Delivered Lumens	LPW	Delivered Lumens	LPW	Delivered Lumens	LPW	Delivered Lumens	LPW		
AL01 (500LM)	6	561	97	574	99	587	101	606	103		
AL01 (750LM)	9	888	100	908	101	930	103	959	106		
AL01 (1000LM)	13	1246	97	1275	98	1305	100	1346	102		
AL02 (1000LM)	13	1321	106	1352	108	1384	110	1427	113		
AL02 (1500LM)	19	1928	103	1973	105	2020	106	2083	109		
AL02 (2000LM)	25	2429	98	2485	99	2544	101	2623	104		
AL03 (2000LM)	25	2499	101	2557	103	2618	105	2699	107		
AL03 (2500LM)	32	3017	96	3087	98	3160	99	3258	102		
AL03 (3000LM)	38	3426	91	3506	93	3589	95	3700	97		

		90CRI									
Lumen Output	Wattage	30K/90CRI		35K/90CRI		40K/90CRI		50K/90CRI			
		Delivered Lumens	LPW	Delivered Lumens	LPW	Delivered Lumens	LPW	Delivered Lumens	LPW		
AL01 (500LM)	6	498	86.5	512	88.3	526	90.1	539	91.8		
AL01 (750LM)	9	789	88.8	810	90.6	832	92.5	853	94.1		
AL01 (1000LM)	13	1108	85.9	1138	87.6	1168	89.4	1198	91.1		
AL02 (1000LM)	13	1174	94.6	1206	96.5	1238	98.5	1270	100.3		
AL02 (1500LM)	19	1714	91.5	1761	93.3	1807	95.3	1854	97.0		
AL02 (2000LM)	25	2159	86.9	2218	88.6	2276	90.5	2335	92.1		
AL03 (2000LM)	25	2222	89.8	2282	91.6	2342	93.6	2402	95.3		
AL03 (2500LM)	32	2682	85.4	2755	87.1	2827	88.9	2900	90.6		
AL03 (3000LM)	38	3046	81.2	3129	82.9	3211	84.6	3294	86.1		

		90CRI									
Lumen Output	Wattage	30K/90CRI		35K/90CRI		40K/90CRI		50K/90CRI			
		Delivered Lumens	LPW	Delivered Lumens	LPW	Delivered Lumens	LPW	Delivered Lumens	LPW		
AL01 (500LM)	6	490	85	503	87	517	89	530	90		
AL01 (750LM)	9	776	87	797	89	818	91	839	93		
AL01 (1000LM)	13	1089	84	1119	86	1148	88	1178	90		
AL02 (1000LM)	13	1155	93	1186	95	1217	97	1248	99		
AL02 (1500LM)	19	1685	90	1731	92	1777	94	1822	95		
AL02 (2000LM)	25	2123	85	2180	87	2238	89	2295	91		
AL03 (2000LM)	25	2184	88	2243	90	2302	92	2362	94		
AL03 (2500LM)	32	2637	84	2708	86	2780	87	2851	89		
AL03 (3000LM)	38	2994	80	3076	81	3157	83	3238	85		

LBR ROUND LUMEN TABLES

LBR6		80CRI							
Lumen Output	Wattage	30K/80CRI		35K/80CRI		40K/80CRI		50K/80CRI	
		Delivered Lumens	LPW	Delivered Lumens	LPW	Delivered Lumens	LPW	Delivered Lumens	LPW
AL01 (500LM)	6	571	99	585	101	599	103	617	105
AL01 (750LM)	9	905	102	926	103	948	105	977	108
AL01 (1000LM)	13	1270	98	1300	100	1330	102	1372	104
AL02 (1000LM)	13	1346	108	1378	110	1410	112	1454	115
AL02 (1500LM)	19	1965	105	2011	107	2059	109	2123	111
AL02 (2000LM)	25	2476	100	2533	101	2593	103	2674	106
AL02 (2500LM)	25	2547	103	2606	105	2668	107	2751	109
AL03 (2500LM)	32	3075	98	3146	100	3221	101	3321	104
AL03 (3000LM)	38	3492	93	3573	95	3658	96	3771	99

LBR6WW		80CRI							
Lumen Output	Wattage	30K/80CRI		35K/80CRI		40K/80CRI		50K/80CRI	
		Delivered Lumens	LPW	Delivered Lumens	LPW	Delivered Lumens	LPW	Delivered Lumens	LPW
AL01 (500LM)	6	570	99	584	101	597	102	616	105
AL01 (750LM)	9	903	102	924	103	946	105	975	108
AL01 (1000LM)	13	1268	98	1297	100	1328	102	1369	104
AL02 (1000LM)	13	1344	108	1375	110	1408	112	1451	115
AL02 (1500LM)	19	1961	105	2007	106	2055	108	2118	111
AL02 (2000LM)	25	2471	99	2528	101	2588	103	2668	105
AL02 (2500LM)	25	2542	103	2601	104	2663	106	2745	109
AL03 (2500LM)	32	3069	98	3140	99	3214	101	3314	103
AL03 (3000LM)	38	3485	93	3566	94	3651	96	3764	98

		90CRI							
Lumen Output	Wattage	30K/90CRI		35K/90CRI		40K/90CRI		50K/90CRI	
		Delivered Lumens	LPW	Delivered Lumens	LPW	Delivered Lumens	LPW	Delivered Lumens	LPW
AL01 (500LM)	6	499	87	513	88	527	90	540	92
AL01 (750LM)	9	791	89	812	91	834	93	855	94
AL01 (1000LM)	13	1110	86	1140	88	1170	90	1200	91
AL02 (1000LM)	13	1177	95	1209	97	1241	99	1272	101
AL02 (1500LM)	19	1718	92	1764	93	1811	95	1857	97
AL02 (2000LM)	25	2164	87	2222	89	2281	91	2340	92
AL03 (2000LM)	25	2226	90	2286	92	2347	94	2407	95
AL03 (2500LM)	32	2687	86	2760	87	2833	89	2906	91
AL03 (3000LM)	38	3052	81	3135	83	3217	85	3300	86

		90CRI							
Lumen Output	Wattage	30K/90CRI		35K/90CRI		40K/90CRI		50K/90CRI	
		Delivered Lumens	LPW	Delivered Lumens	LPW	Delivered Lumens	LPW	Delivered Lumens	LPW
AL01 (500LM)	6	498	87	512	88	526	90	539	92
AL01 (750LM)	9	789	89	810	91	832	92	853	94
AL01 (1000LM)	13	1108	86	1138	88	1168	89	1198	91
AL02 (1000LM)	13	1174	95	1206	97	1238	99	1270	100
AL02 (1500LM)	19	1714	91	1761	93	1807	95	1854	97
AL02 (2000LM)	25	2159	87	2218	89	2276	91	2335	92
AL03 (2000LM)	25	2222	90	2282	92	2342	94	2402	95
AL03 (2500LM)	32	2682	85	2755	87	2827	89	2900	91
AL03 (3000LM)	38	3046	81	3129	83	3211	85	3294	86

LBR8		80CRI							
Lumen Output	Wattage	30K/80CRI		35K/80CRI		40K/80CRI		50K/80CRI	
		Delivered Lumens	LPW	Delivered Lumens	LPW	Delivered Lumens	LPW	Delivered Lumens	LPW
AL01 (500LM)	6	551	96	564	97	577	99	595	101
AL01 (750LM)	9	872	98	893	100	914	102	942	104
AL01 (1000LM)	13	1225	95	1253	96	1283	98	1323	101
AL02 (1000LM)	13	1298	105	1328	106	1360	108	1402	111
AL02 (1500LM)	19	1895	101	1939	103	1985	105	2047	107
AL02 (2000LM)	25	2387	96	2442	98	2500	99	2578	102
AL03 (2000LM)	25	2456	99	2513	101	2572	103	2652	105
AL03 (2500LM)	32	2965	94	3034	96	3106	98	3202	100
AL03 (3000LM)	38	3367	90	3445	91	3527	93	3636	95

LBR8WW		80CRI							
Lumen Output	Wattage	30K/80CRI		35K/80CRI		40K/80CRI		50K/80CRI	
		Delivered Lumens	LPW	Delivered Lumens	LPW	Delivered Lumens	LPW	Delivered Lumens	LPW
AL01 (500LM)	6	552	96	565	97	578	99	596	101
AL01 (750LM)	9	874	98	894	100	915	102	943	104
AL01 (1000LM)	13	1227	95	1255	97	1285	98	1325	101
AL02 (1000LM)	13	1300	105	1330	106	1362	108	1404	111
AL02 (1500LM)	19	1898	101	1942	103	1988	105	2050	107
AL02 (2000LM)	25	2391	96	2446	98	2504	100	2582	102
AL03 (2000LM)	25	2460	99	2517	101	2576	103	2656	105
AL03 (2500LM)	32	2969	95	3038	96	3110	98	3207	100
AL03 (3000LM)	38	3372	90	3451	91	3532	93	3642	95

		90CRI							
Lumen Output	Wattage	30K/90CRI		35K/90CRI		40K/90CRI		50K/90CRI	
		Delivered Lumens	LPW	Delivered Lumens	LPW	Delivered Lumens	LPW	Delivered Lumens	LPW
AL01 (500LM)	6	482	84	495	85	508	87	521	89
AL01 (750LM)	9	762	86	783	87	804	89	824	91
AL01 (1000LM)	13	1070	83	1099	85	1128	86	1157	88
AL02 (1000LM)	13	1135	91	1165	93	1196	95	1227	97
AL02 (1500LM)	19	1656	88	1701	90	1746	92	1791	94
AL02 (2000LM)	25	2086	84	2143	86	2199	87	2256	89
AL03 (2000LM)	25	2146	87	2205	89	2263	90	2321	92
AL03 (2500LM)	32	2591	83	2661	84	2732	86	2802	87
AL03 (3000LM)	38	2943	78	3023	80	3102	82	3182	83

		90CRI							
Lumen Output	Wattage	30K/90CRI		35K/90CRI		40K/90CRI		50K/90CRI	
		Delivered Lumens	LPW	Delivered Lumens	LPW	Delivered Lumens	LPW	Delivered Lumens	LPW
AL01 (500LM)	6	482	84	495	85	508	87	522	89
AL01 (750LM)	9	764	86	784	88	805	89	826	91
AL01 (1000LM)	13	1072	83	1101	85	1130	87	1159	88
AL02 (1000LM)	13	1136	92	1167	93	1198	95	1229	97
AL02 (1500LM)	19	1659	89	1704	90	1749	92	1794	94
AL02 (2000LM)	25	2089	84	2146	86	2203	88	2259	89
AL03 (2000LM)	25	2150	87	2208	89	2266	91	2325	92
AL03 (2500LM)	32	2595	83	2666	84	2736	86	2806	88
AL03 (3000LM)	38	2947	79	3027	80	3107	82	3187	83

PLENUM DEPTH TABLE				
Aperture Size/Output	PLENUM DEPTH*	IC	NON-IC	NON-IC MARKED SPACINGS
LBR4 500-1000 LM	3.44	X		
LBR4 1000-2000 LM	3.44			
LBR4 2000-3000 LM	3.44			24 x 24 x 9
LBR6 500-1000 LM	3.69		X	
LBR6 1000-2000 LM	3.69			
LBR6 2000-3000 LM	3.69			24 x 24 x 9
LBR8 500-1000 LM	5.81	X		
LBR8 1000-2000 LM	5.81			
LBR8 2000-3000 LM	5.81			24 x 24 x 9

*Above unfinished 1/2" ceiling plane

CEILING COVERAGE TABLE								
Series		Aperture	Trim Flange OD	Min ceiling opening	Ceiling Thickness	Max ceiling opening	Max Ceiling Opening with Goof Ring	Overall Goof Ring OD
LBR4	ROUND	4-1/4"	5-7/16"	4-1/2"	1/2"	5-1/8"	5-1/8"	7-1/4"
LBR4					1-1/2"		5-3/4"	
LBR6		5-5/16"	7-5/8"	5-3/4"	1/2"	7-1/8"	7-1/8"	9-1/4"
LBR6					1-1/2"		7-3/8"	
LBR8		7-1/6"	9-3/16"	7-3/4"	1/2"	8-7/8"	9-1/4"	11-1/4"
LBR8					1-1/2"		9-5/8"	

DIMMER COMPATIBILITY

Not compatible with DALI or DMX dimmers. For specific compatible dimmers see below.

LINE VOLTAGE DIMMING:					
Type	Forward Phase	S (500-1000lm)	M (1000-2000lm)	L (2000-3000lm)	Comment
MLV	Lutron Glyder GLV-600	YES	YES	YES	
INC	Leviton SureSlide 6633	YES	YES	YES	
MLV	Lutron Diva DVLV-600P	YES	YES	YES	
MLV	Lutron Skylark SLV-600P	YES	YES	YES	
INC	Lutron RadioRA 2 10ND	YES	YES	YES	
MLV	Leviton SureSlide 6613-PLW	YES	YES	YES	
INC	Lutron Diva DVCL-153P	YES	YES	YES	
MLV	Leviton IPM06	YES, 2x *	YES	YES	* min 2 fixtures
INC	Leviton IPI06	YES, 2x *	YES	YES	* min 2 fixtures
MLV	Synergy ISD 600LV	YES, 2x *	YES	YES	* min 2 fixtures
INC	Synergy ISD 600I	YES, 2x *	YES	YES	* min 2 fixtures
INC	Control4 C4-FPD 120	YES	YES	YES	
Type	Reverse Phase Dimmer Bank	S (500-1000lm)	M (1000-2000lm)	L (2000-3000lm)	
ELV	Lutron Nova T NTELV-600	YES	YES	YES	
ELV	Lutron Diva DVELV 600P	YES	YES	YES	
ELV	Lutron Maestro MAELV 600	YES	YES	YES	
ELV	Leviton Vizia VPE06-1LX	YES	YES	YES	
ELV	Leviton Illumatech IPE04	YES	YES	YES	
ELV	Control4 C4-APD 120 REVERSE PHASE	YES	YES	YES	
Type	Miscellaneous Dimmers	S (500-1000lm)	M (1000-2000lm)	L (2000-3000lm)	
PHA	Lutron RadioRA2 RRD-6NA	YES	YES	YES	
PHA	Lutron Maestro PRO LED+ RRD-PRO	YES	YES	YES	
Type	Control Systems	S (500-1000lm)	M (1000-2000lm)	L (2000-3000lm)	
MLV	Lutron LP-RPM-4U	YES	YES	YES	
PHA	Lutron LP-RPM-4A	YES	YES	YES	
MLV	Lutron GRAPHIC EYE QSGRJ-3P	YES	YES	YES	
PHA	Lutron PA Power Module PHPM-PA-120	YES	YES	YES	
ELV	Lutron nLight nSP5PCD ELV	YES	YES	YES	

DIMMER COMPATIBILITY

Not compatible with DALI or DMX dimmers. For specific compatible dimmers see below.

0-10V DIMMING:						
Manufacturer	System Type	Description	P/N	S (500-1000lm)	M (1000-2000lm)	L (2000-3000lm)
Lutron	Other	0-10V (sink or source) PowPak wireless dimming module	RMJ-5T-DV-B	YES	YES	YES
Wattstopper	Control System	Digital single relay room controller (0-10V)	LMRC-211	YES	YES	YES
Crestron	Control System	DIN Rail 0-10V fluorescent dimmer, 4 feeds, 4 channels (Green Light System)	DIN-4DIMFLV4	YES	YES	YES
Lutron	Other	Grafik Eye 0-10V adapter	GRX-TVI	YES	YES	YES
Leviton	Wall Box	Illumatech 0-10V	IP710-DLX	YES	YES	YES
Lutron	Control System	Mounted in the Homeworks QS panel - 0-10V dimmer (sink or source)	GRX-TVM2	YES	YES	YES
Lutron	Wall Box	Nova 0-10V wallbox dimmer (use with PP-120-H line voltage relay)	NTFTV	YES	YES	YES
Lutron	Wall Box	Nova 0-10V wallbox dimmer (use with PP-120-H line voltage relay)	NTSTV-DV	YES	YES	YES
Lutron	Wall Box	Nova T	NFTV	YES	YES	YES
Leviton	Wall Box	Renior II 0-10V	AWSMG-7DW	YES	YES	YES
ACUITY	Wall Box	sensorswitch, wall switch sensor, occupancy controlled dimming	WSX D WH	YES	YES	YES
ACUITY	Control System	nLight	nPP16D	YES	YES	YES
ACUITY	Control System	nLight	nPS 80 EZ	YES	YES	YES
ACUITY	Control System	nLight Air	rPP20 D	YES	YES	YES

L5: Utility Lighting

Lighting to replace existing surface mounted utility style lighting back steel fire escape and along back sides of building.

Conduit and Electrical Boxes already Existing.

Location noted on Building Elevations.



WAC LIGHTING

Bandeau

Outdoor Wall Sconce

Fixture Type: Attachment C.56

Catalog Number: _____

Project: _____

Location: _____

Model & Size	Color Temp	Finish	LED Watts	LED Lumens	Delivered Lumens
WS-W21116 16"	3000K	BK Black	20W	1200	640
	3500K		20W	1200	640
	4000K		20W	1200	640

Example: **WS-W21116-40-BK**

For custom requests please contact customs@wacighting.com

DESCRIPTION

Just the right bandwidth to stream illumination

FEATURES

- Silk screen mitered tempered glass diffuser
- 3CCT (3000K/3500K/4000K) selectable switch
- Option to pre-select color temperature or adjust in the field
- ACLED driverless technology
- 5 year warranty

SPECIFICATIONS

Color Temp:	3000K,3500K,4000K
Input:	120 VAC,50/60Hz
CRI:	90
Dimming:	ELV: 100-10% ,TRIAC: 100-10%
Rated Life:	50000 Hours
Mounting:	Can be mounted on wall in all orientations
Standards:	ETL, cETL,IP65,Title 24 JA8 Compliant
	Wet Location Listed
Construction:	Aluminum body, glass diffuser

REPLACEMENT PARTS

RPL-GLA-21116-OUT - Outer Glass

RPL-GLA-21116-IN - Inner Glass



FINISHES:



Black

LINE DRAWING:

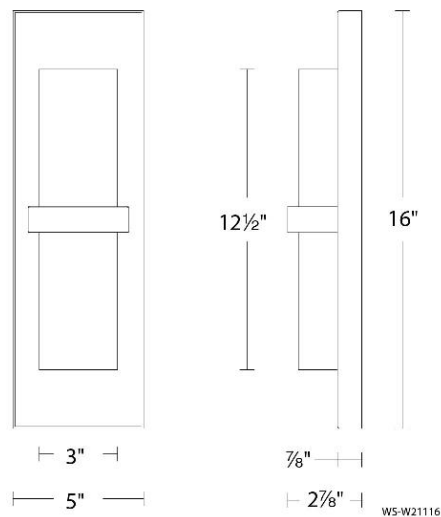

WAC LIGHTING

Bandeau

Outdoor Wall Sconce

Model & Size	Color Temp	Finish	LED Watts	LED Lumens	Delivered Lumens
WS-W21122 22"	3000K	BK Black	20W	1600	739
	3500K		20W	1600	739
	4000K		20W	1600	739

Fixture Type: Attachment C.57

Catalog Number: _____

Project: _____

Location: _____

Example: **WS-W21122-40-BK**

For custom requests please contact customs@wacighting.com

DESCRIPTION

Just the right bandwidth to stream illumination

FEATURES

- Silk screen mitered tempered glass diffuser
- 3CCT (3000K/3500K/4000K) selectable switch
- Option to pre-select color temperature or adjust in the field
- ACLED driverless technology
- 5 year warranty

SPECIFICATIONS

Color Temp:	3000K,3500K,4000K
Input:	120 VAC,50/60Hz
CRI:	90
Dimming:	ELV: 100-10% ,TRIAC: 100-10%
Rated Life:	50000 Hours
Mounting:	Can be mounted on wall in all orientations
Standards:	ETL, cETL,IP65,Title 24 JA8 Compliant
	Wet Location Listed
Construction:	Aluminum body, glass diffuser

REPLACEMENT PARTS

- RPL-GLA-21122-OUT - Outer Glass
- RPL-GLA-21122-IN - Inner Glass



FINISHES:



Black

LINE DRAWING:

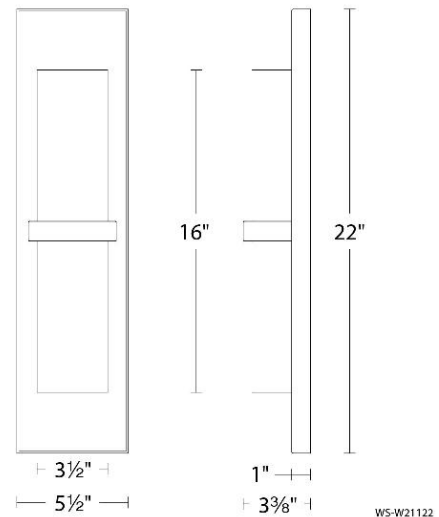



ARCHITECT
VARTONE ARCHITECTURE, LLC
CHRISTINA LARSON
PH: (541) 497-2954
231 2nd AVE SW
ALBANY, OR 97321
LAND USE PLANNER
UDELL ENGINEERING
LAURA LAROQUE
PH: (541) 451-6125
63 E ASH ST.
LEBANON, OR 97355

NOT FOR
CONSTRUCTION

ALBANY FEDERAL BUILDING
HISTORIC REVIEW
240 SW 2ND AVE
ALBANY, OR 97321

Issue: HISTORIC REVIEW
Date: 09-04-2024

Revision:	Date:

SITE PLAN

HR-1

GENERAL SITE PLAN NOTES:

1. UPDATED PARKING LOT LAYOUT WILL BE FINALIZED BY CIVIL ENGINEER AT LATER DATE. SECONDARY ENTRY IS BEING ADDED TO THE BUILDING IN ORDER TO PROVIDE ADA ENTRY WITH EXISTING ADA RAMP. MODIFICATIONS WILL BE MADE TO RAMP IN ORDER TO ACCOMMODATE UPDATED CODE REQUIREMENTS.
2. FOR LIGHT FIXTURE SELECTIONS (SIGNATED AS L-1, L-2, ETC.) SEE LIGHTING CUTSHEET PACKAGE.

LEGEND:

- LANDSCAPE
- PAVING
- CONCRETE SIDEWALK AND CURBS

KEYNOTE LEGEND	
#	Keynote Description
01-03	NEW ADA PARKING SPACE, FINAL LAYOUT BY CIVIL

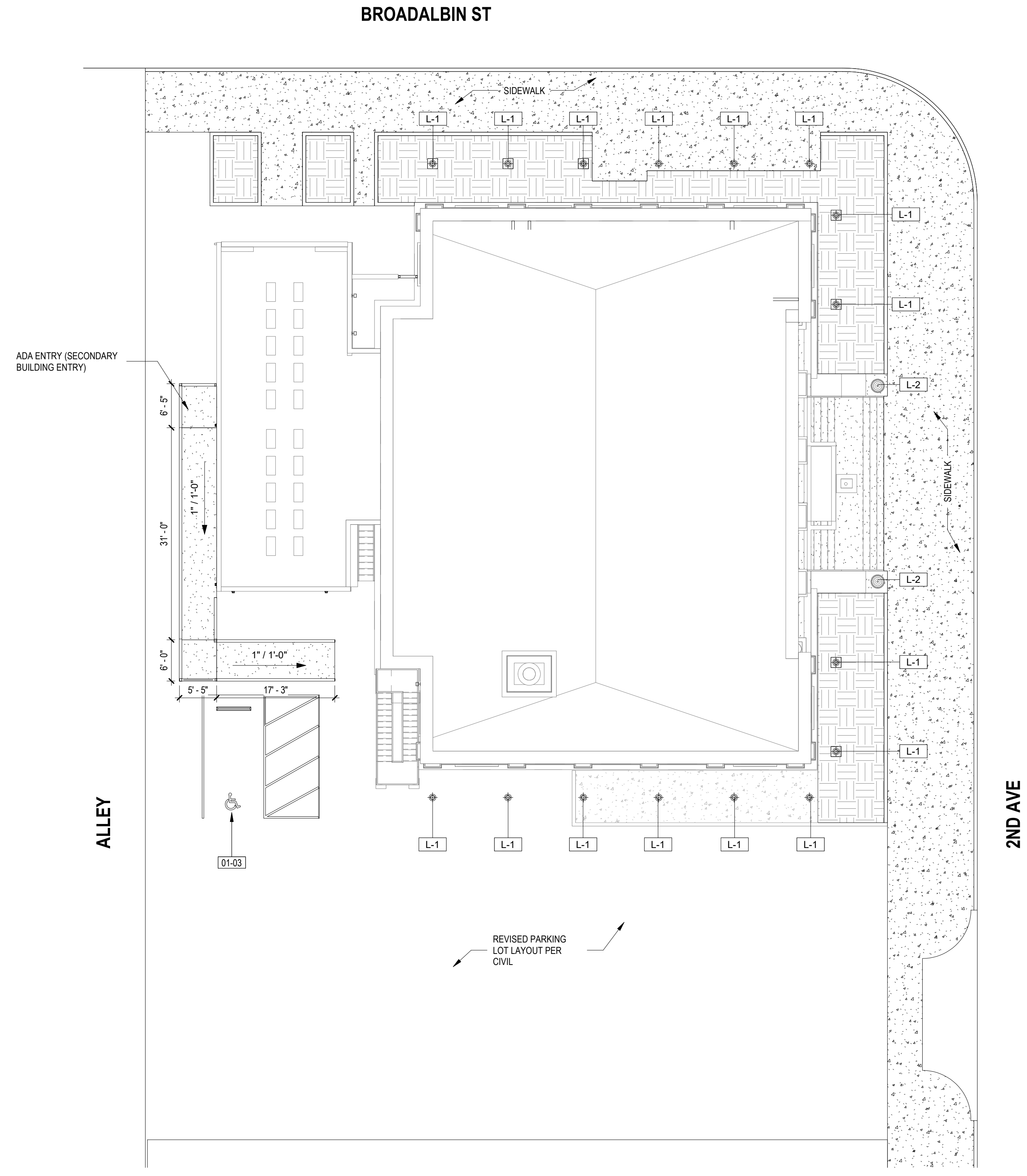

01 SITE PLAN
3/32" = 1'-0"

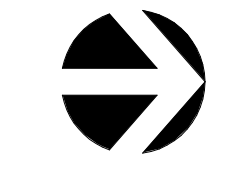

KEYNOTE LEGEND	
#	Keynote Description
02-03	REMOVE (E) RAMP AND RAILING TO REPLACE WITH NEW ADA COMPLIANT RAMP AND RAILING
02-04	REMOVE (E) DOOR AND INFILL WALL TO MATCH (E)
02-05	REMOVE (E) BLOCK TO EXPOSE ORIGINAL WINDOWS. RESTORE AND REINSTALL WINDOWS
02-06	REMOVE (E) WINDOW, INSTALL NEW WINDOW AND INFILL UPPER PORTION PARGE COAT TO MATCH EXISTING SURFACE
02-07	REPLACE (E) METAL DOOR WITH FULL-LITE DOOR
02-10	(E) ROOF TO REMAIN
02-12	REMOVE (E) LIGHT FIXTURE, MAINT (E) LOCATION FOR NEW LIGHT
02-15	REMOVE (E) METAL STAIR AND RAILING
02-16	REMOVE (E) WINDOW INFILL
02-21	(E) LIGHT FOR FLAG POLE TO REMAIN
02-22	REMOVE (E) STOREFRONT
02-23	REMOVE (E) LIGHT FIXTURE, PATCH AND REPAIR WALL
02-24	REMOVE (E) STOREFRONT DOOR AND REPLACE WITH NEW STOREFRONT



VARITONE
ARCHITECTURE

231 2nd Avenue SW
Albany, Oregon 97321
Ph: 541.497.2954

ARCHITECT
VARITONE ARCHITECTURE, LLC
CHRISTINA LARSON
PH: (541) 497-2954
231 2nd AVE SW
ALBANY, OR 97321

LAND USE PLANNER
UDELL ENGINEERING
LAURA LAROQUE
PH: (541) 451-6125
63 E ASH ST.
LEBANON, OR 97355



01 EXISTING/DEMOLITION ELEVATION NORTH
3/16" = 1'-0"

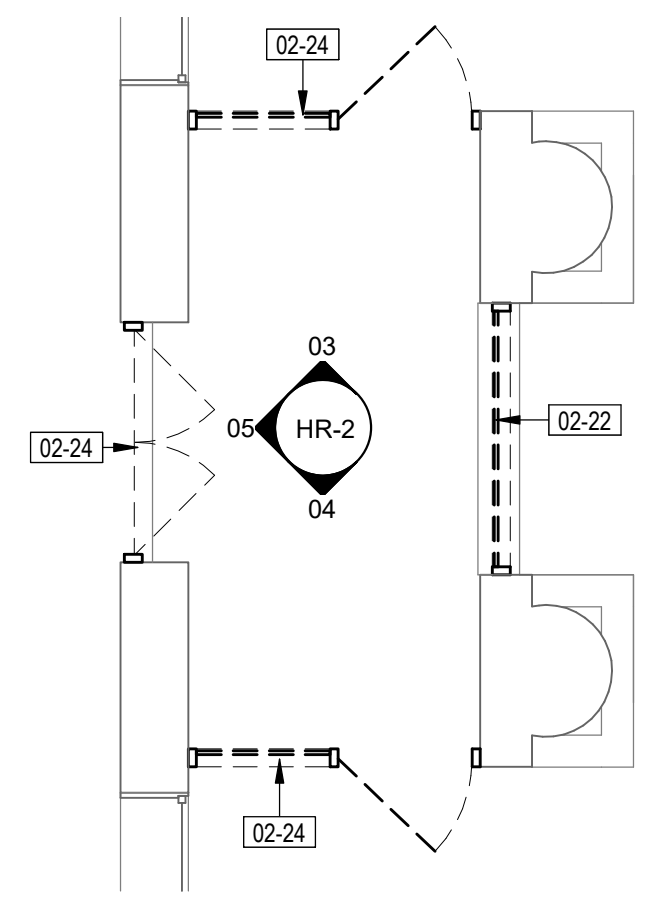

06 DEMO ENLARGED VESTIBULE PLAN
1/4" = 1'-0"

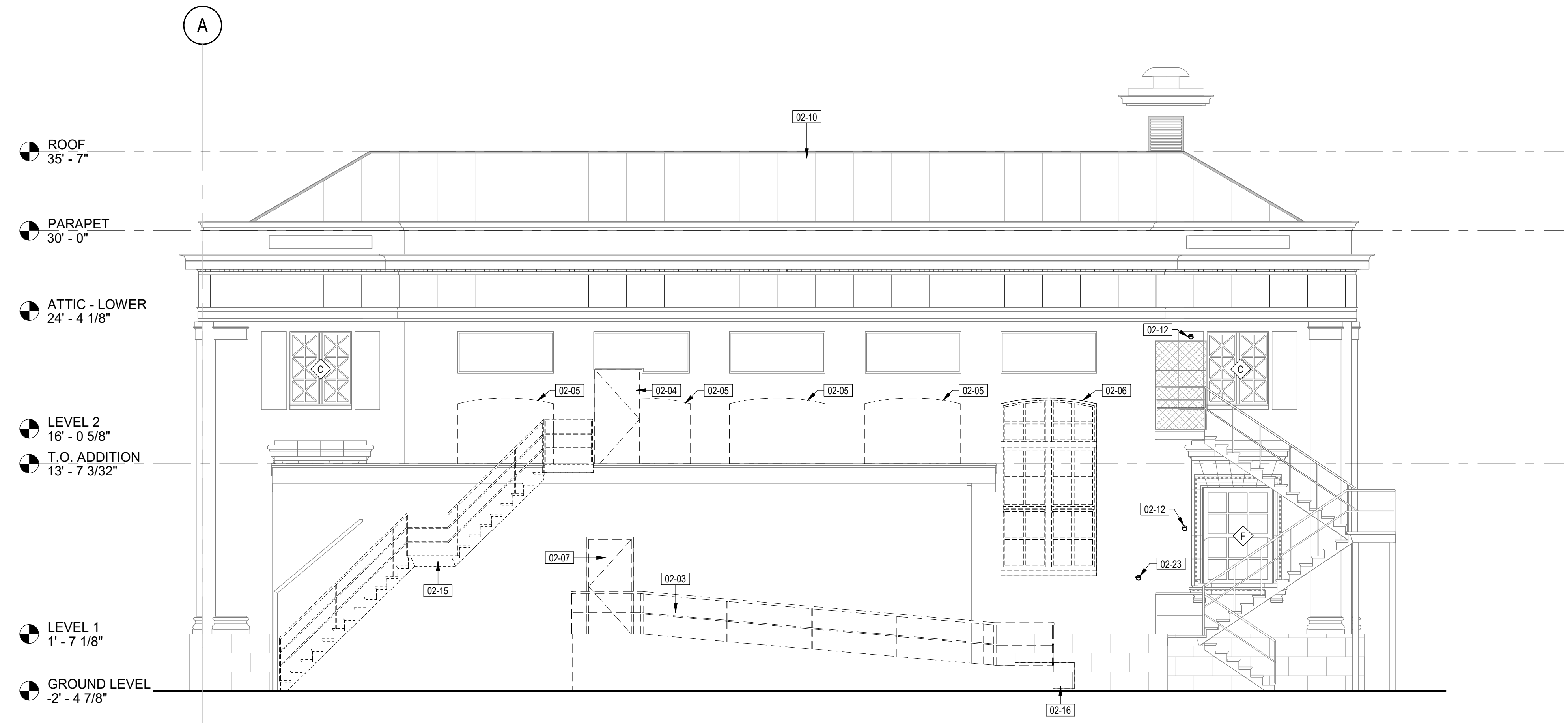

02 EXISTING/DEMOLITION ELEVATION SOUTH
3/16" = 1'-0"

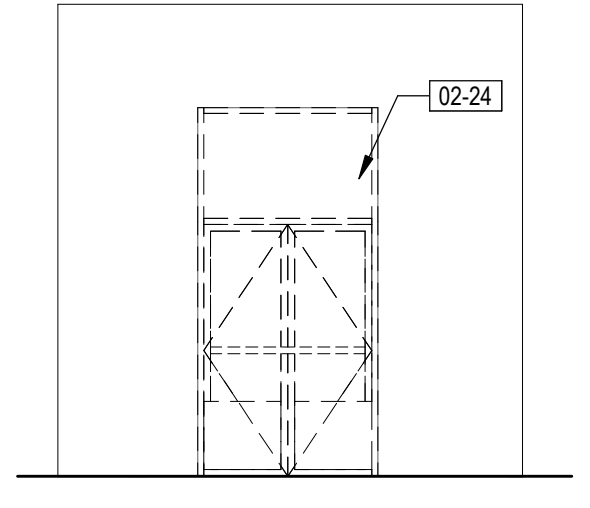

05 DEMO VESTIBULE ELEVATION
3/16" = 1'-0"

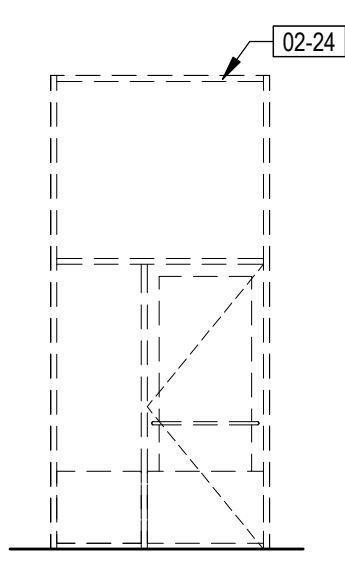

03 DEMO VESTIBULE ELEVATION
3/16" = 1'-0"

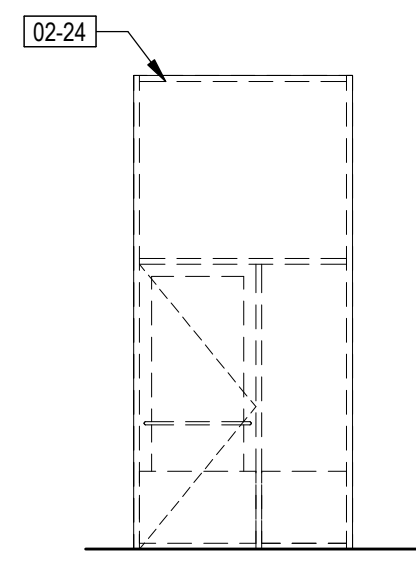

04 DEMO VESTIBULE ELEVATION
3/16" = 1'-0"

NOT FOR
CONSTRUCTION

ALBANY FEDERAL BUILDING
HISTORIC REVIEW

240 SW 2ND AVE
ALBANY, OR 97321

Issue: HISTORIC REVIEW
Date: 09-04-2024

Revision:	Date:

DEMOLITION
EXTERIOR
ELEVATIONS

HR-2

KEYNOTE LEGEND	
#	Keynote Description
02-03	REMOVE (E) RAMP AND RAILING TO REPLACE WITH NEW ADA COMPLIANT RAMP AND RAILING
02-10	(E) ROOF TO REMAIN
02-11	REMOVE (E) WOOD DOOR AND REPLACE WITH NEW FULL-LITE WOOD DOOR.
02-15	REMOVE (E) METAL STAIR AND RAILING
02-16	REMOVE (E) WINDOW INFILL
02-17	REMOVE (E) DOOR ON SIDE WALL AND INFILL OPENING WITH A 1" RECESS
02-25	REMOVE (E) BARS
02-26	REMOVE (E) CONCRETE STAIR
02-27	REMOVE (E) RECESSED WALL AND WINDOWS



ARCHITECT
 VARTONE ARCHITECTURE, LLC
 CHRISTINA LARSON
 PH: (541) 497-2954
 231 2nd AVE SW
 ALBANY, OR 97321

LAND USE PLANNER
 UDELL ENGINEERING
 LAURA LAROQUE
 PH: (541) 451-6125
 63 E ASH ST.
 LEBANON, OR 97355

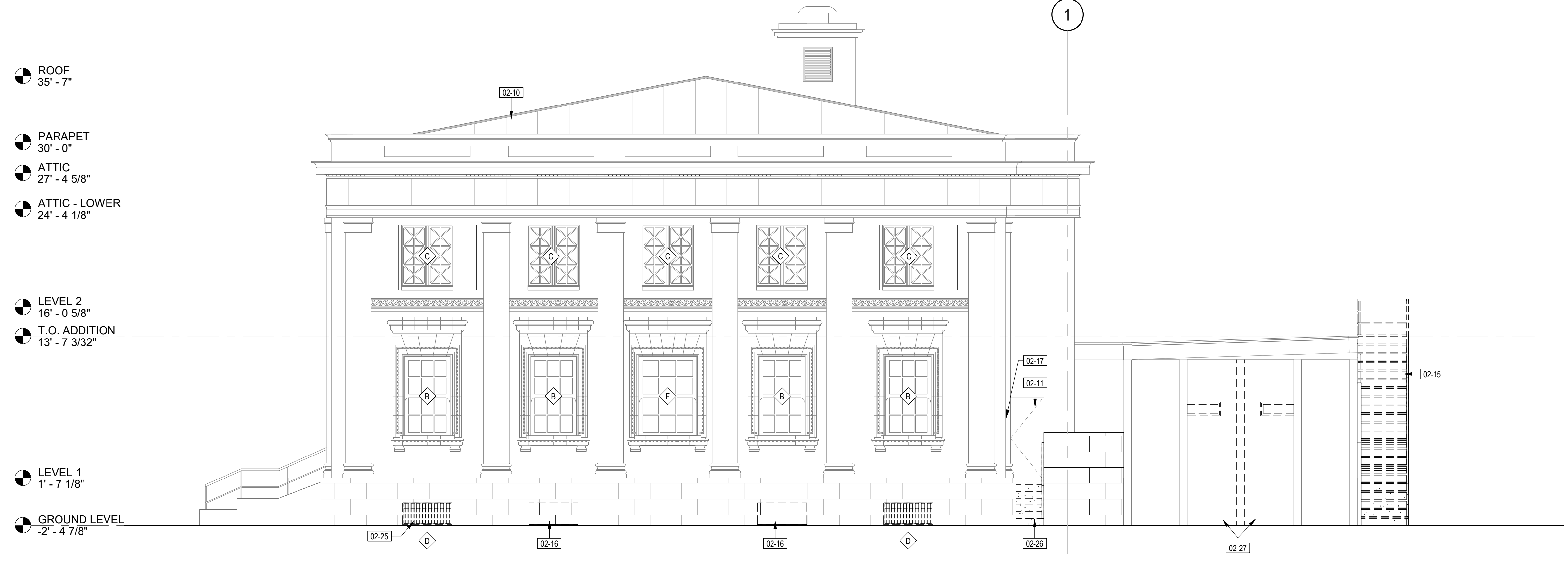

01 EXISTING/DEMOLITION ELEVATION WEST
 3/16" = 1'-0"

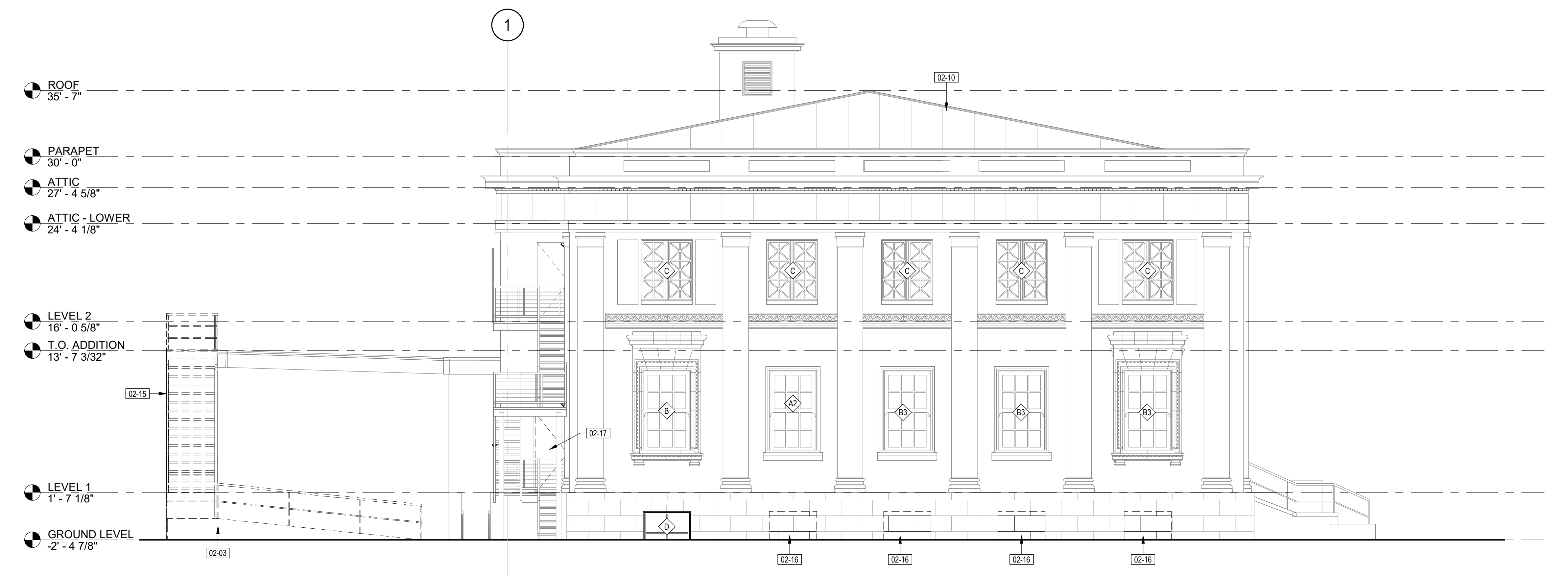

02 EXISTING/DEMOLITION ELEVATION EAST
 3/16" = 1'-0"

NOT FOR CONSTRUCTION
 ALBANY FEDERAL BUILDING
 HISTORIC REVIEW
 240 SW 2ND AVE
 ALBANY, OR 97321

Issue:	HISTORIC REVIEW
Date:	09-04-2024
Revision:	Date:

DEMOLITION
 EXTERIOR
 ELEVATIONS

HR-3



VARTONE ARCHITECTURE
231 2nd Avenue SW
Albany, Oregon 97321
Ph: 541.497.2954

ARCHITECT
VARTONE ARCHITECTURE, LLC
CHRISTINA LARSON
PH: (541) 497-2954
231 2nd AVE SW
ALBANY, OR 97321

LAND USE PLANNER
UDELL ENGINEERING
LAURA LAROQUE
PH: (541) 451-6125
63 E ASH ST.
LEBANON, OR 97355

ALBANY FEDERAL BUILDING
HISTORIC REVIEW

240 SW 2ND AVE
ALBANY, OR 97321

Issue: HISTORIC REVIEW
Date: 09-04-2024

Revision:	Date:

EXTERIOR ELEVATIONS

HR-4

- FINISH LEGEND**
- (E) LIMESTONE TO BE CLEANED BUT OTHERWISE LEFT UNTOUCHED.
 - EXISTING STUCCO TO BE PAINTED: SW 7645 THUNDER GRAY
 - EXISTING STUCCO TO BE PAINTED: SW 6102 PORTABELLO
 - EXISTING STUCCO TO BE PAINTED: SW 6108 LATTE
 - EXISTING STUCCO TO BE PAINTED: SW 6141 SOFTER TAN

KEYNOTE LEGEND

#	Keynote Description
02-02	(E) HANDRAILS TO REMAIN.
02-20	WALL INFILL WITH SLIGHT RECESS TO MATCH PANELS ABOVE
03-01	NEW CODE COMPLIANT RAMP
08-02	EXISTING HOLLOW METAL DOOR TO BE REPLACED WITH NEW FULL LITE HOLLOW METAL DOOR
09-01	INFILL (E) DOOR OPENING AND PARGE COAT TO MATCH (E) SURFACE
09-02	RESTORE PLASTER WORK ON ORIGINAL PANEL AFTER DOOR REMOVAL
13-02	(E) STEEL FIRE ESCAPE TO BE REPAINTED.
23-01	MECHANICAL UNIT
26-01	LED ACCENT LIGHTING TO RUN ALONG TOP INSIDE EDGE OF CORNICE
26-02	CEILING LIGHTING TO REPLACE (E) LIGHTING WITHIN EXTERIOR PORTION ENTRY
26-03	NEW EXTERIOR LIGHT FIXTURE TO ILLUMINATE ADA RAMP. INSTALLED WITH NEW RECESSED ELECTRICAL BOX
26-04	(E) UTILITY LIGHT FIXTURE TO BE REPLACED WITH NEW DECORATIVE LIGHT FIXTURE. LOCATION TO REMAIN THE SAME.

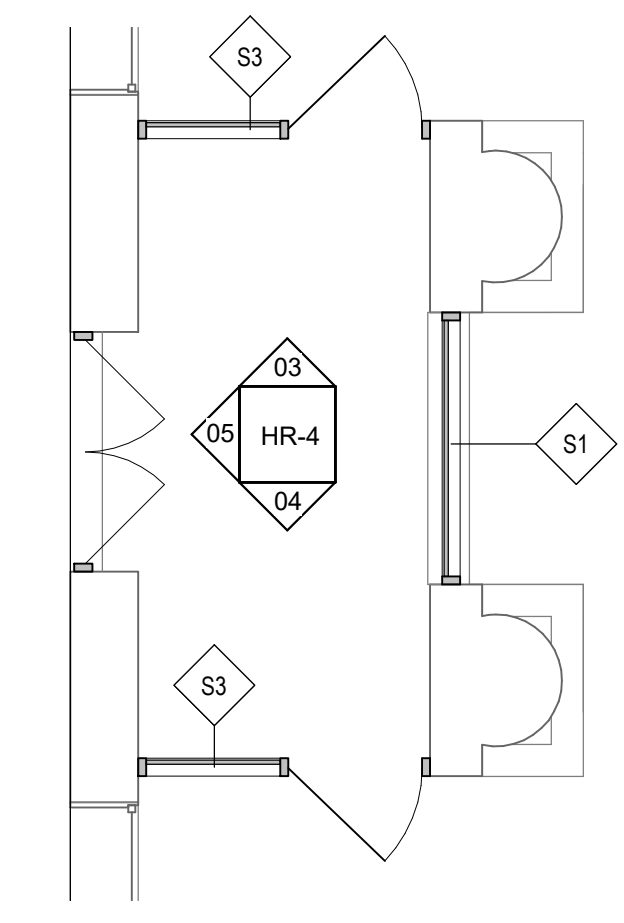

06 ENLARGED VESTIBULE PLAN
1/4" = 1'-0"

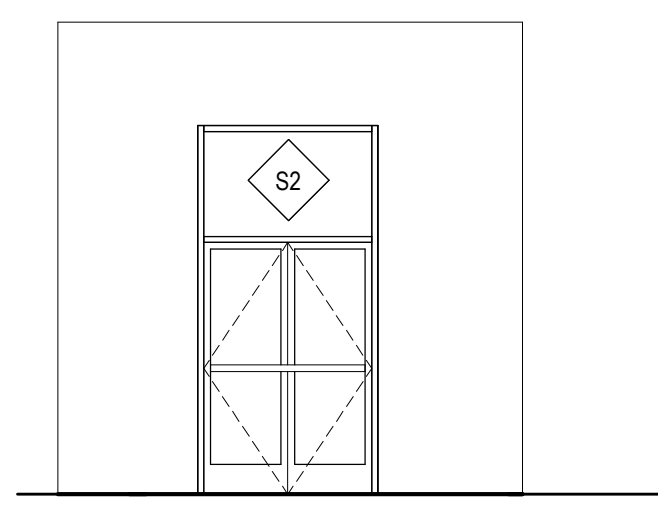

05 VESTIBULE ELEVATION
3/16" = 1'-0"



03 VESTIBULE ELEVATION
3/16" = 1'-0"

04 VESTIBULE ELEVATION
3/16" = 1'-0"

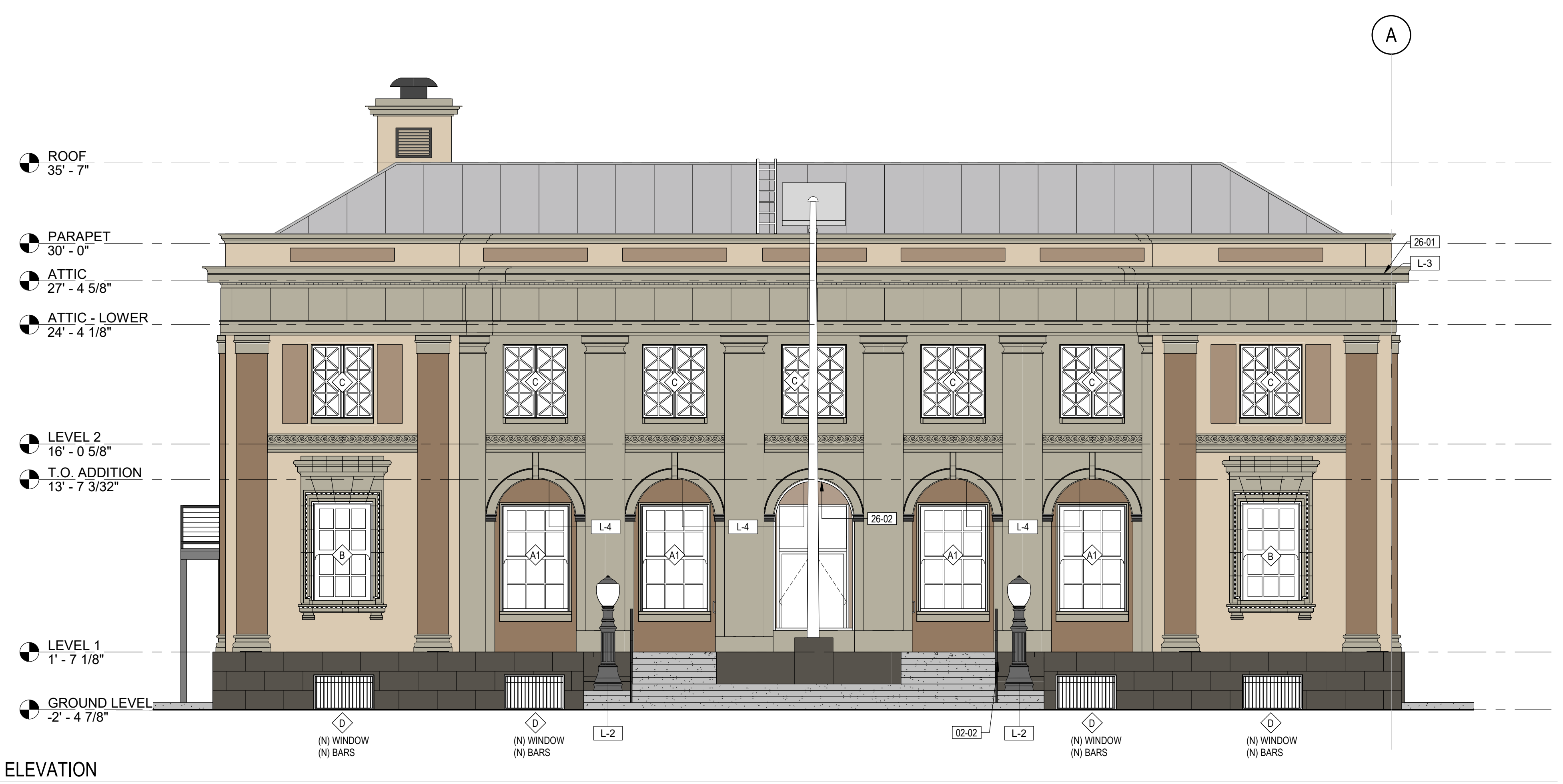

01 NORTH ELEVATION
3/16" = 1'-0"



02 SOUTH ELEVATION
3/16" = 1'-0"



ARCHITECT
VARTONE ARCHITECTURE, LLC
CHRISTINA LARSON
PH: (541) 497-2954
231 2nd AVE SW
ALBANY, OR 97321
LAND USE PLANNER
UDELL ENGINEERING
LAURA LAROQUE
PH: (541) 451-6125
63 E ASH ST.
LEBANON, OR 97355

FINISH LEGEND

	(E) LIMESTONE TO BE CLEANED BUT OTHERWISE LEFT UNTOUCHED.
	EXISTING STUCCO TO BE PAINTED: SW 7645 THUNDER GRAY
	EXISTING STUCCO TO BE PAINTED: SW 6102 PORTABELLO
	EXISTING STUCCO TO BE PAINTED: SW 6108 LATTIE
	EXISTING STUCCO TO BE PAINTED: SW 6141 SOFTER TAN

KEYNOTE LEGEND

#	Keynote Description
02-02	(E) HANDRAILS TO REMAIN.
02-11	REMOVE (E) WOOD DOOR AND REPLACE WITH NEW FULL-LITE WOOD DOOR.
02-18	REMOVE (E) DOOR. INFILL WITH STUCCO PANEL WITH 1" RECESS FROM FACE OF FACADE
02-19	(E) DOOR TO REMAIN. PAINTED
05-01	NEW STEEL RAILING
11-01	MECHANICAL UNIT
13-02	(E) STEEL FIRE ESCAPE TO BE REPAINTED.
26-01	LED ACCENT LIGHTING TO RUN ALONG TOP INSIDE EDGE OF CORNICE
26-03	NEW EXTERIOR LIGHT FIXTURE TO ILLUMINATE ADA RAMP. INSTALLED WITH NEW RECESSED ELECTRICAL BOX

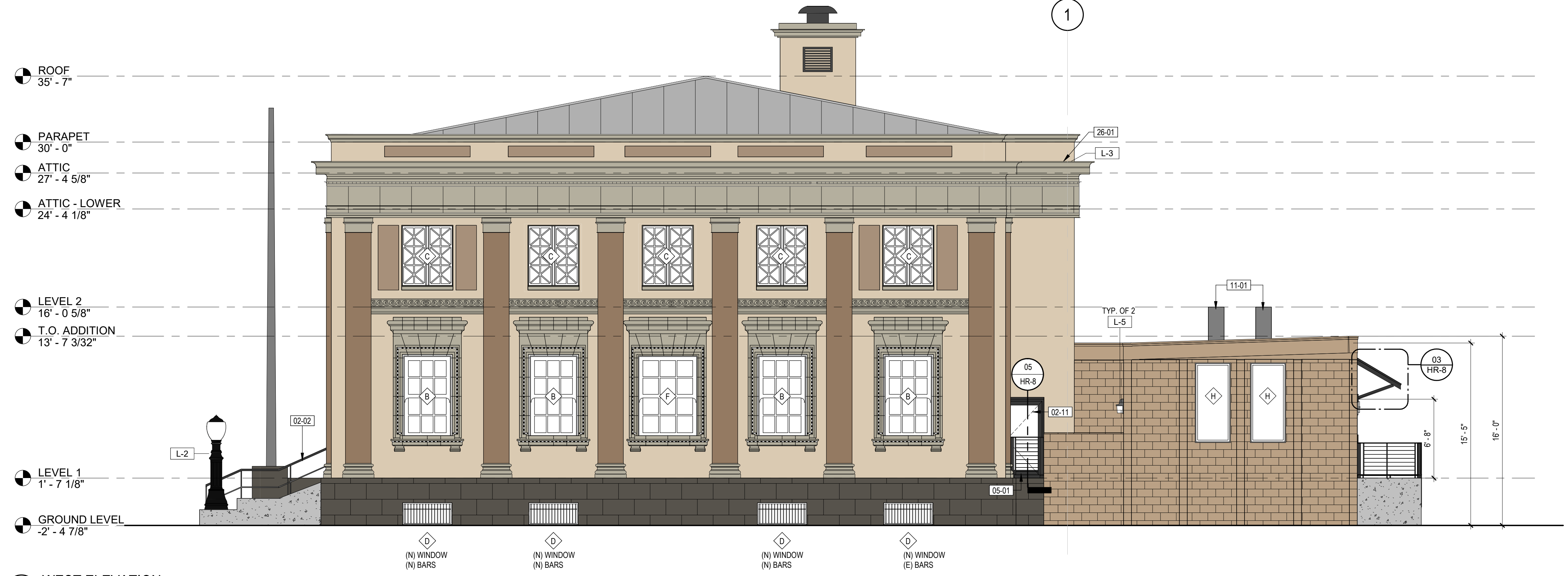

01 WEST ELEVATION
3/16" = 1'-0"

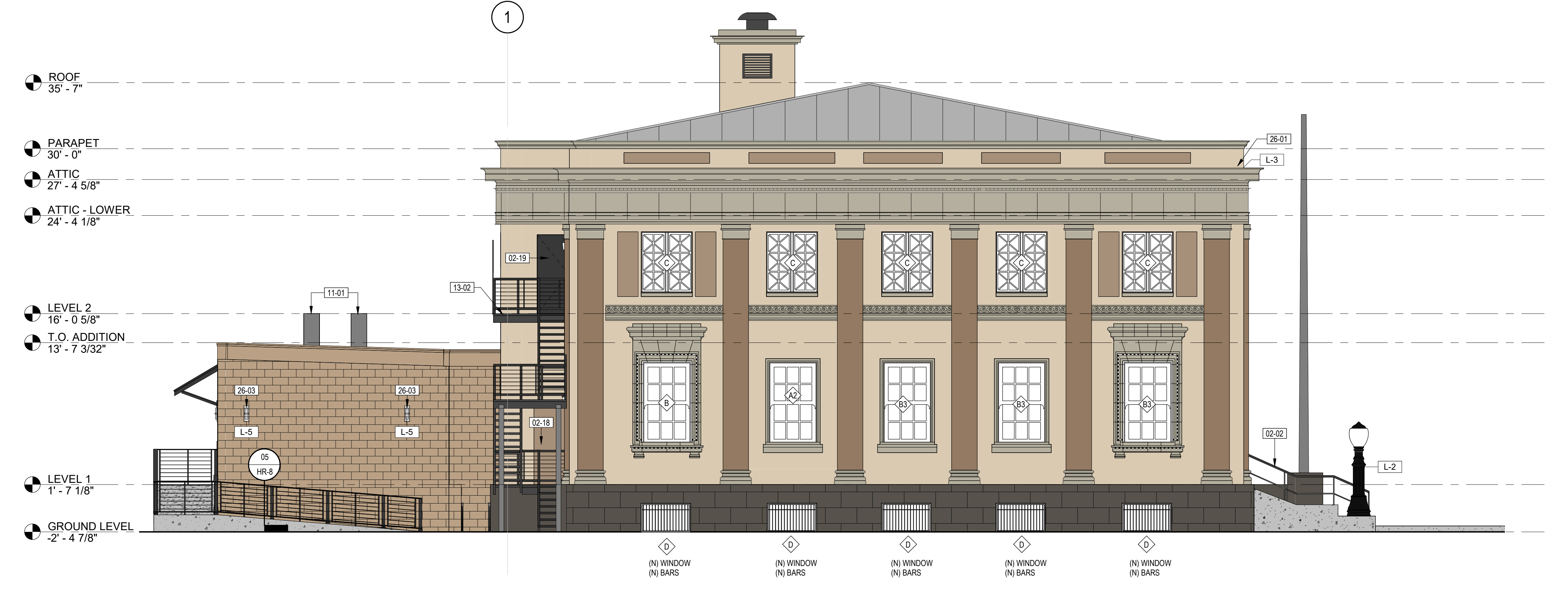

02 EAST ELEVATION
3/16" = 1'-0"

ALBANY FEDERAL BUILDING
HISTORIC REVIEW
240 SW 2ND AVE
ALBANY, OR 97321

Issue: HISTORIC REVIEW
Date: 09-04-2024

Revision:	Date:

EXTERIOR ELEVATIONS

HR-5

Revision:	Date:

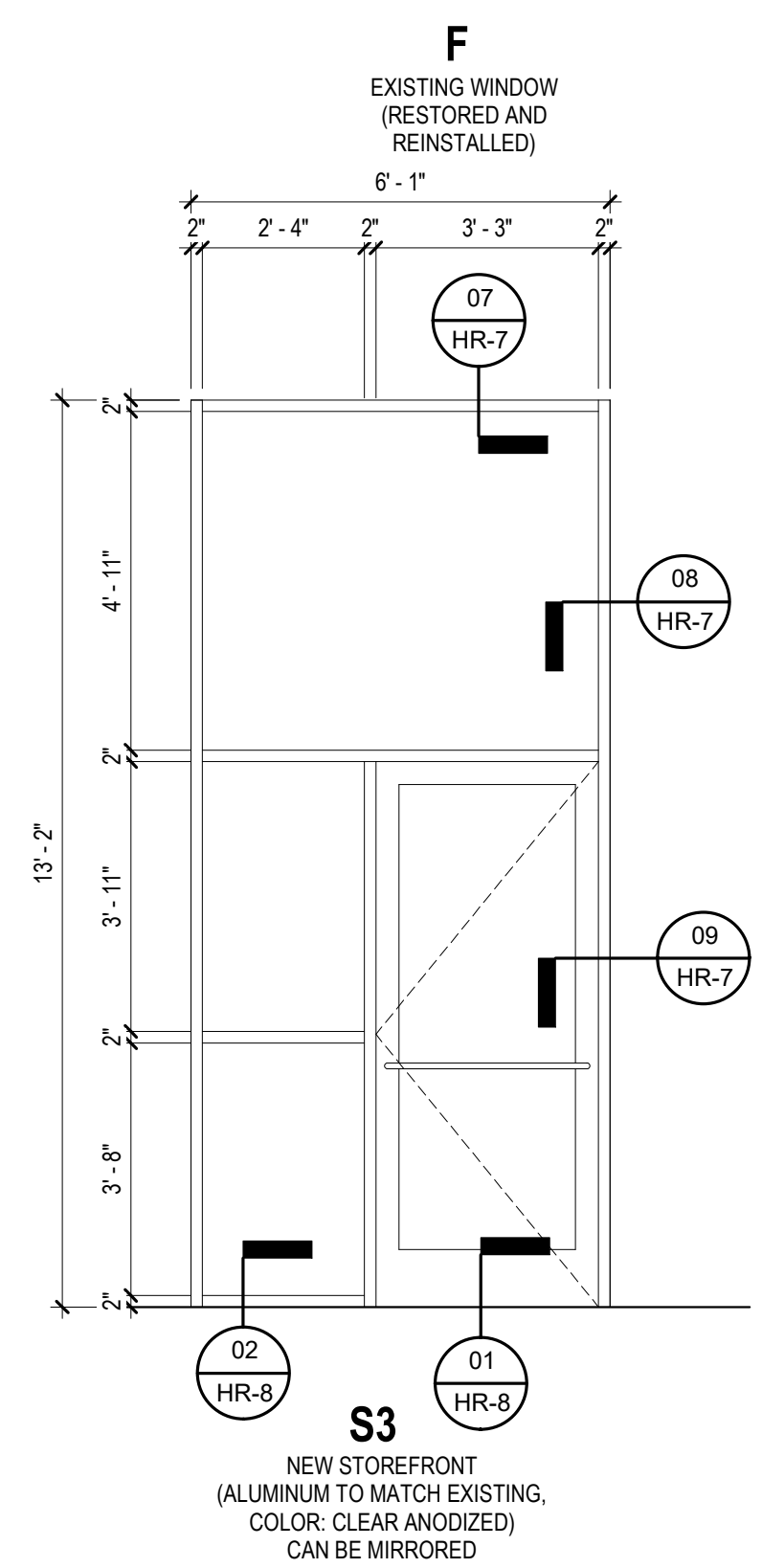
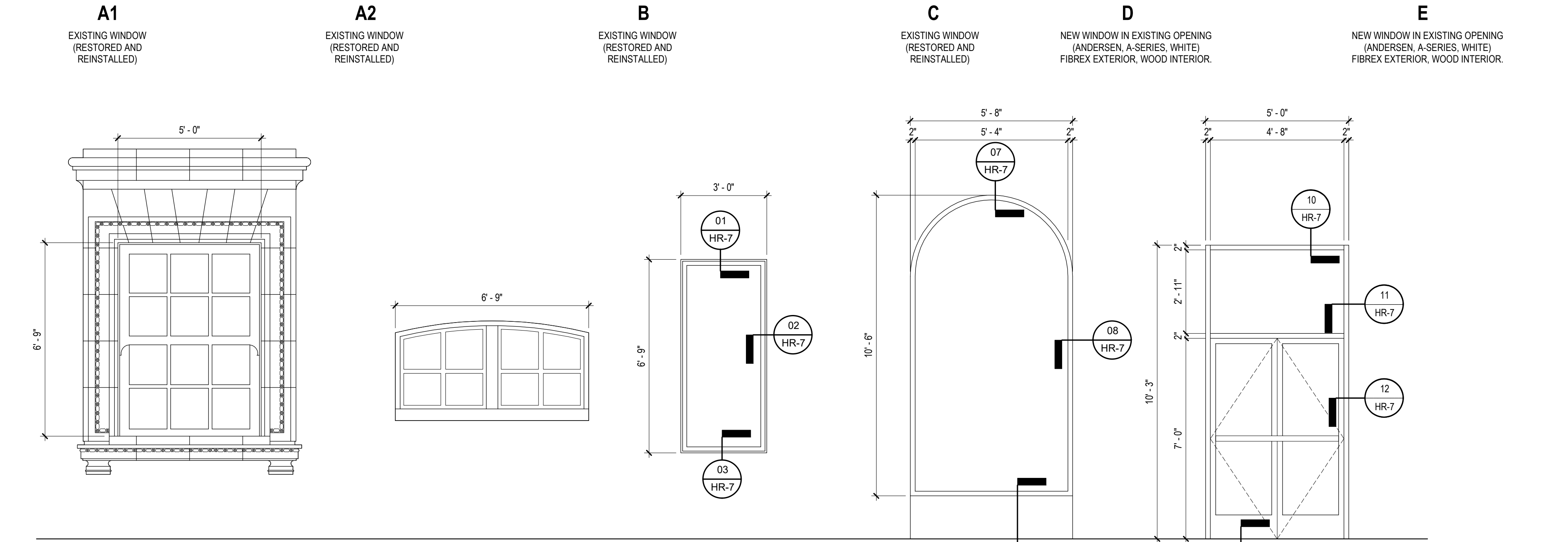
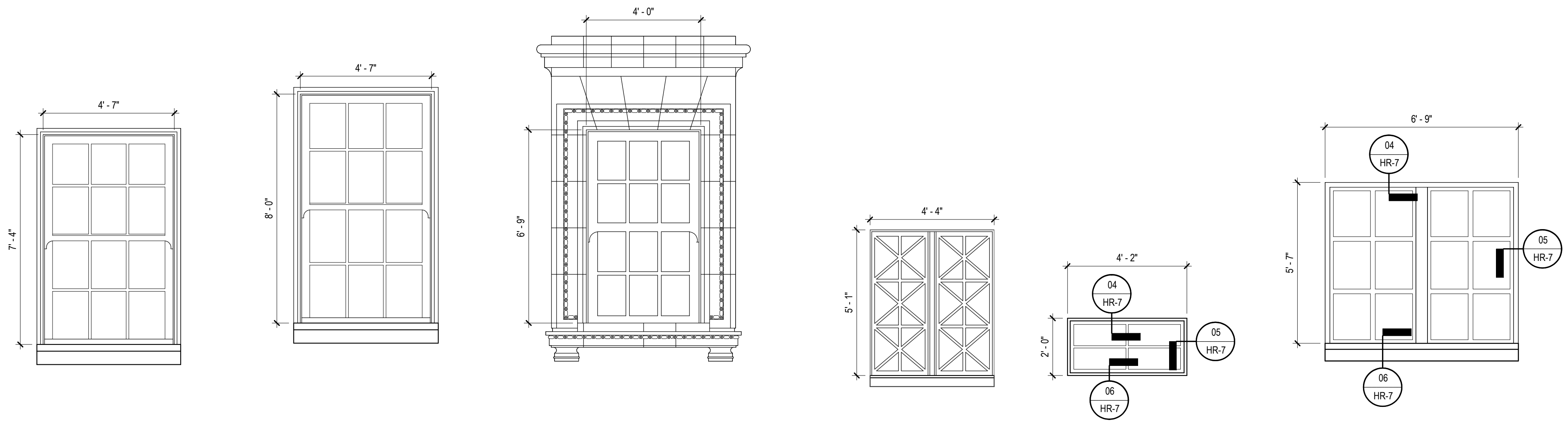

01 WINDOW TYPES
 3/8" = 1'-0"

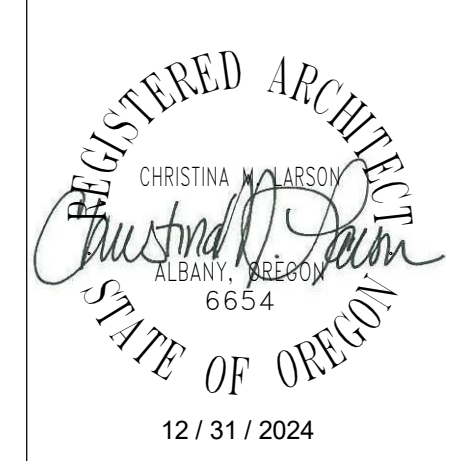

VARITONE
ARCHITECTURE
231 2nd Avenue SW
Albany, Oregon 97321
Ph: 541.497.2954

ARCHITECT
VARITONE ARCHITECTURE, LLC
CHRISTINA LARSON
PH: (541) 497-2954
231 2nd AVE SW
ALBANY, OR 97321
LAND USE PLANNER
UDELL ENGINEERING
LAURA LAROQUE
PH: (541) 451-6125
63 E ASH ST.
LEBANON, OR 97355

ALBANY FEDERAL BUILDING
HISTORIC REVIEW
240 SW 2ND AVE
ALBANY, OR 97321

Issue: HISTORIC REVIEW
Date: 09-04-2024

Revision: _____ Date: _____

DETAILS

HR-7

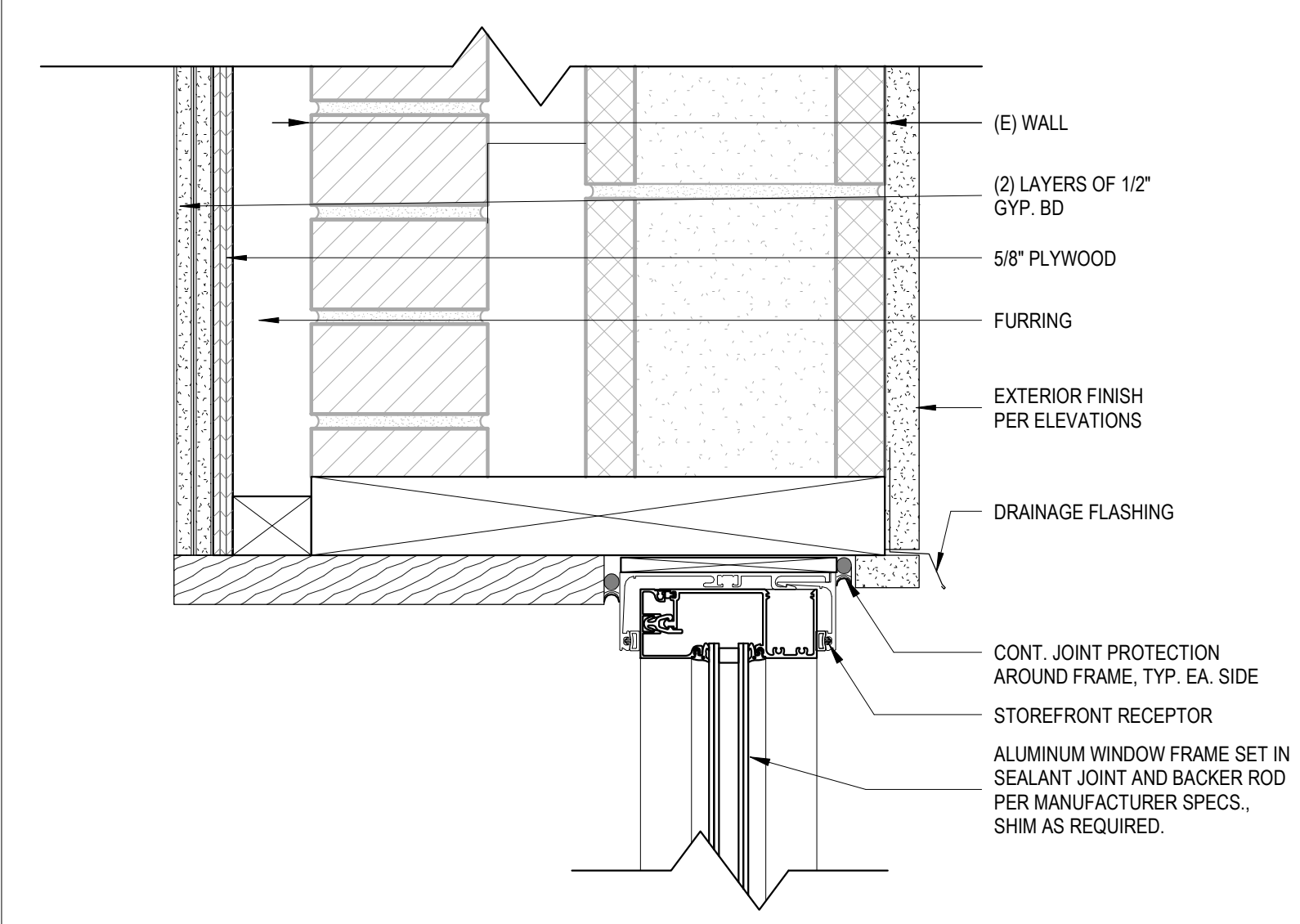

10 STOREFRONT HEAD @ (E) WALL
3" = 1'-0"

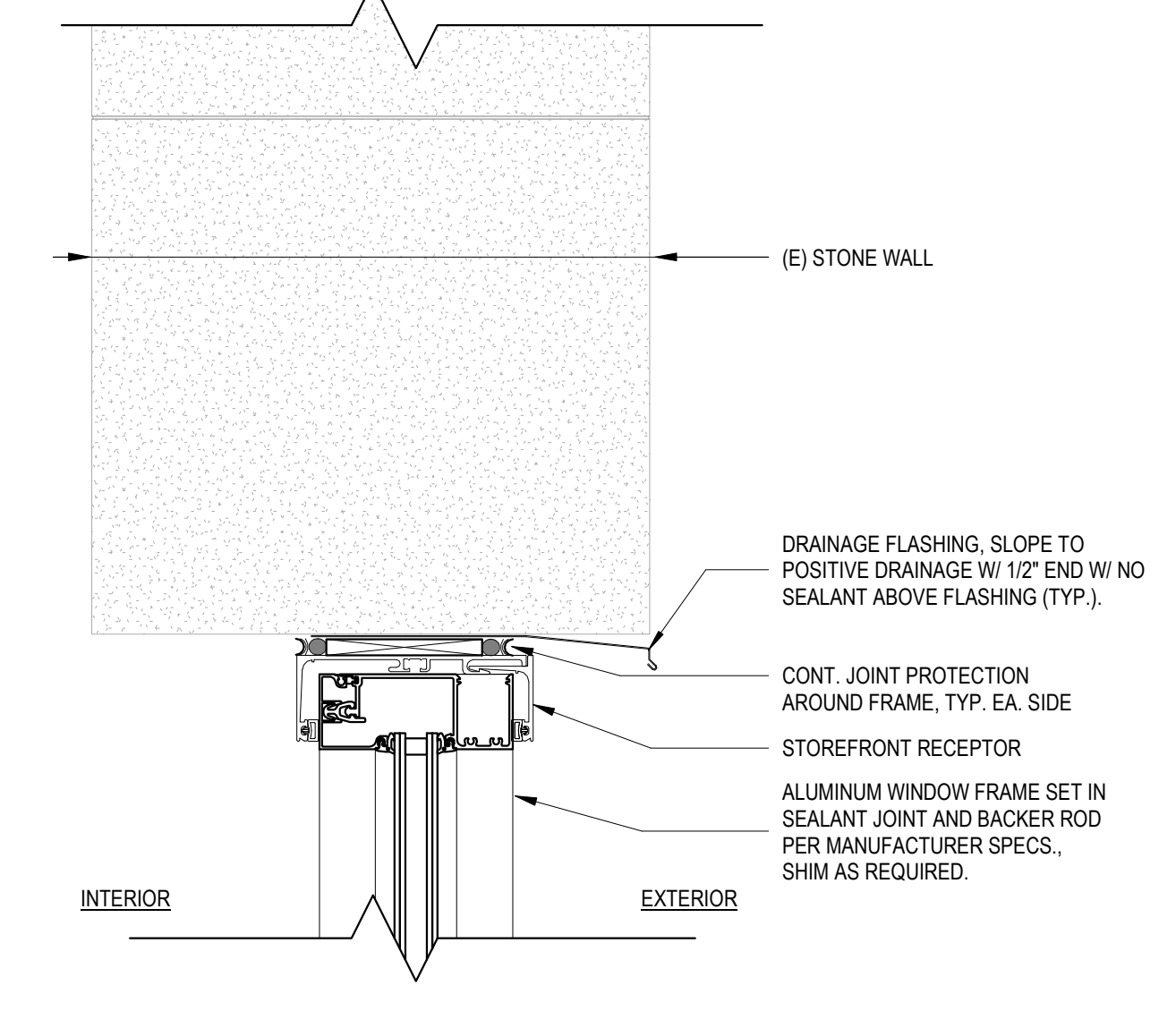

07 STOREFRONT HEAD @ STONE WALL
3" = 1'-0"

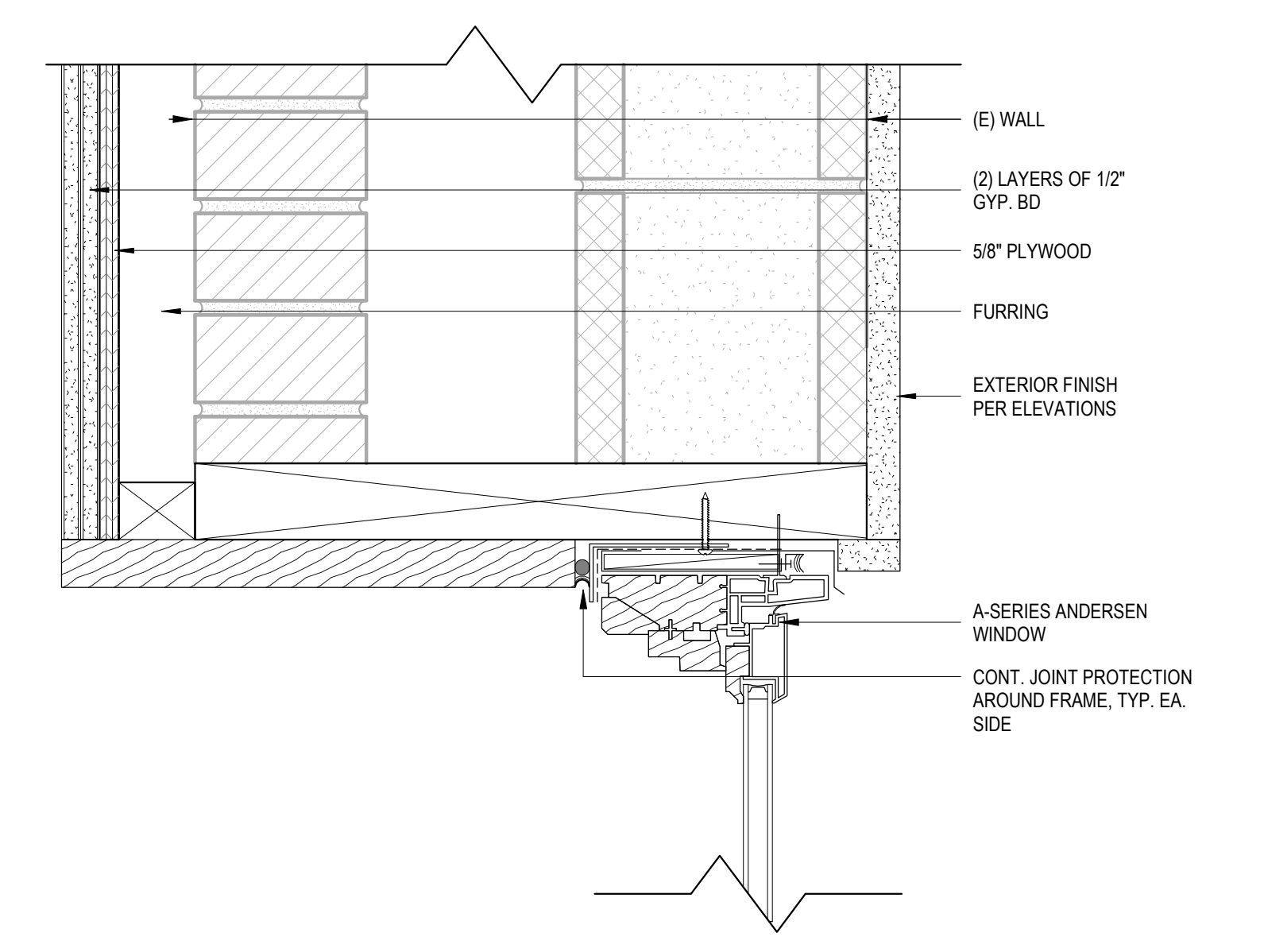

04 WINDOW HEAD @ (E) WALL
3" = 1'-0"

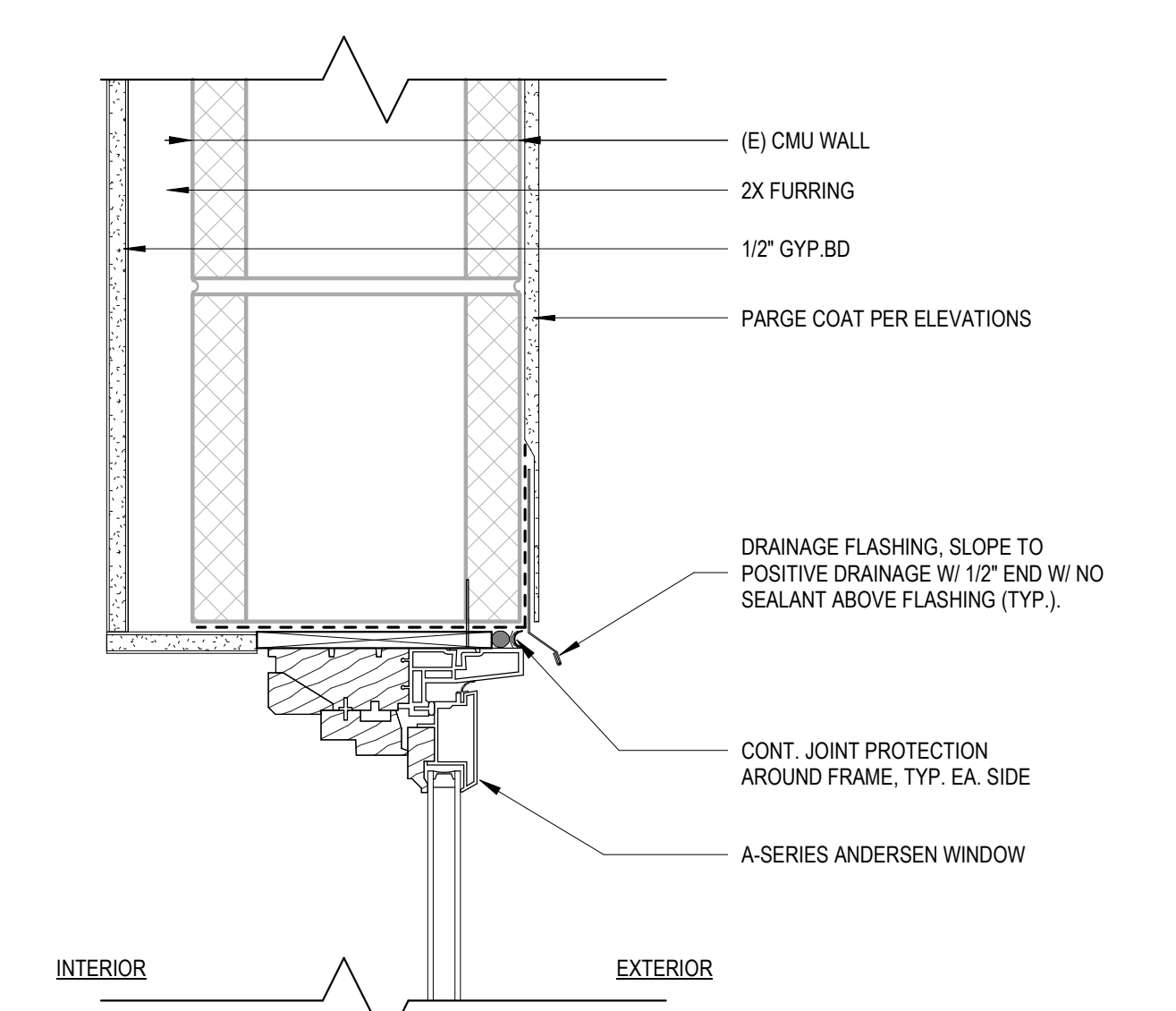

01 WINDOW HEAD @ CMU
3" = 1'-0"

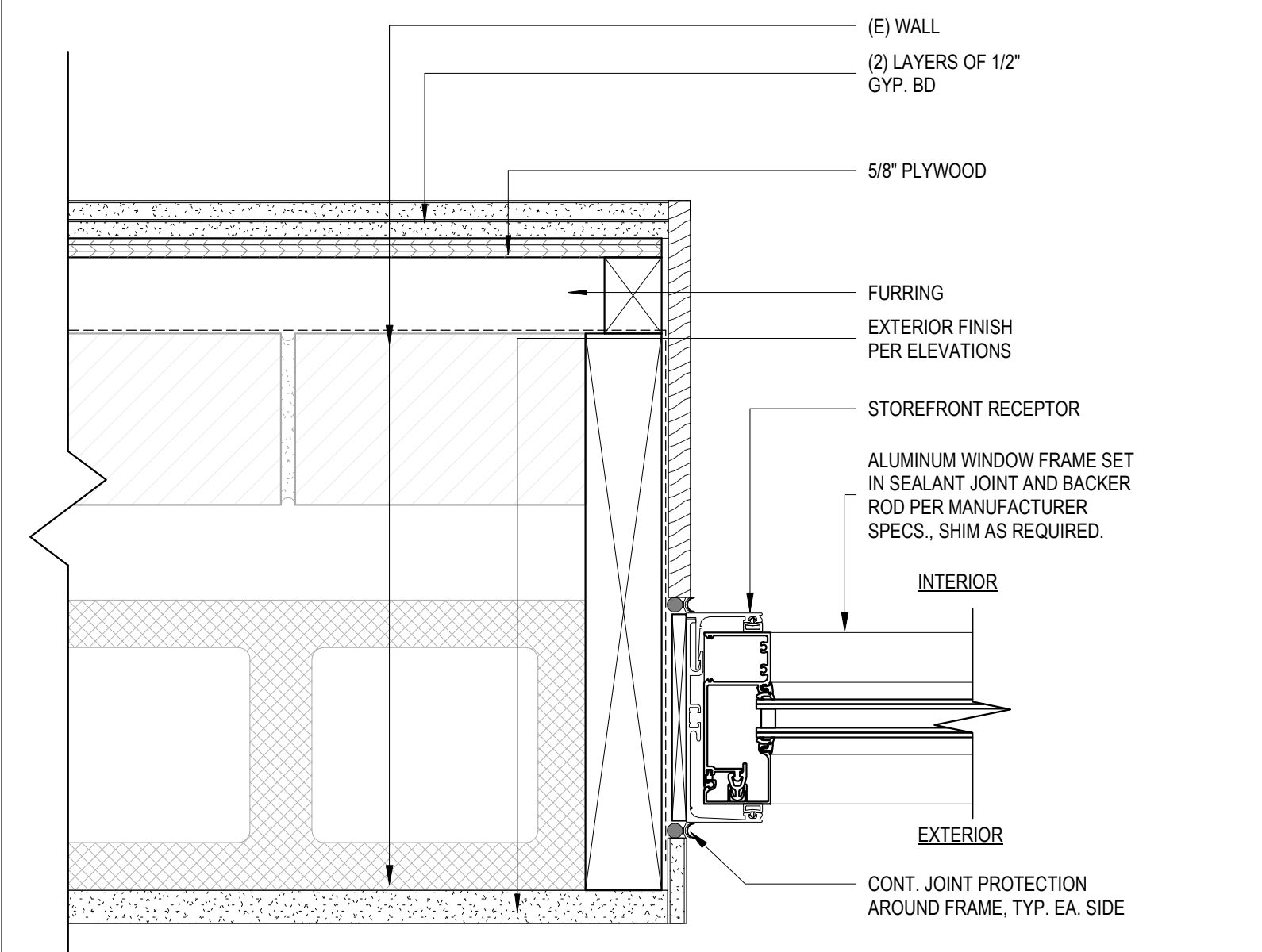

11 STOREFRONT JAMB @ (E) WALL
3" = 1'-0"

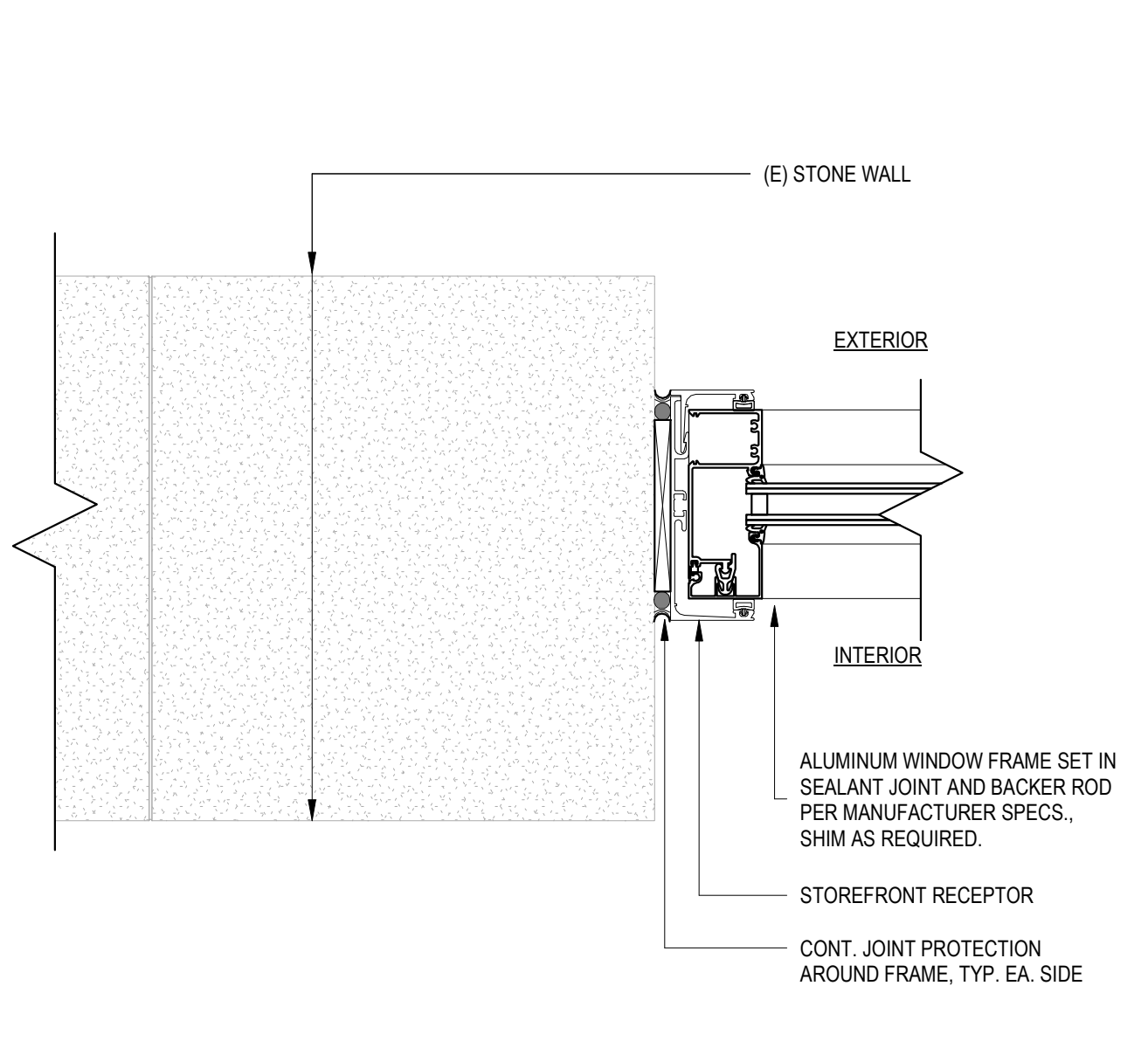

08 STOREFRONT JAMB @ STONE WALL
3" = 1'-0"

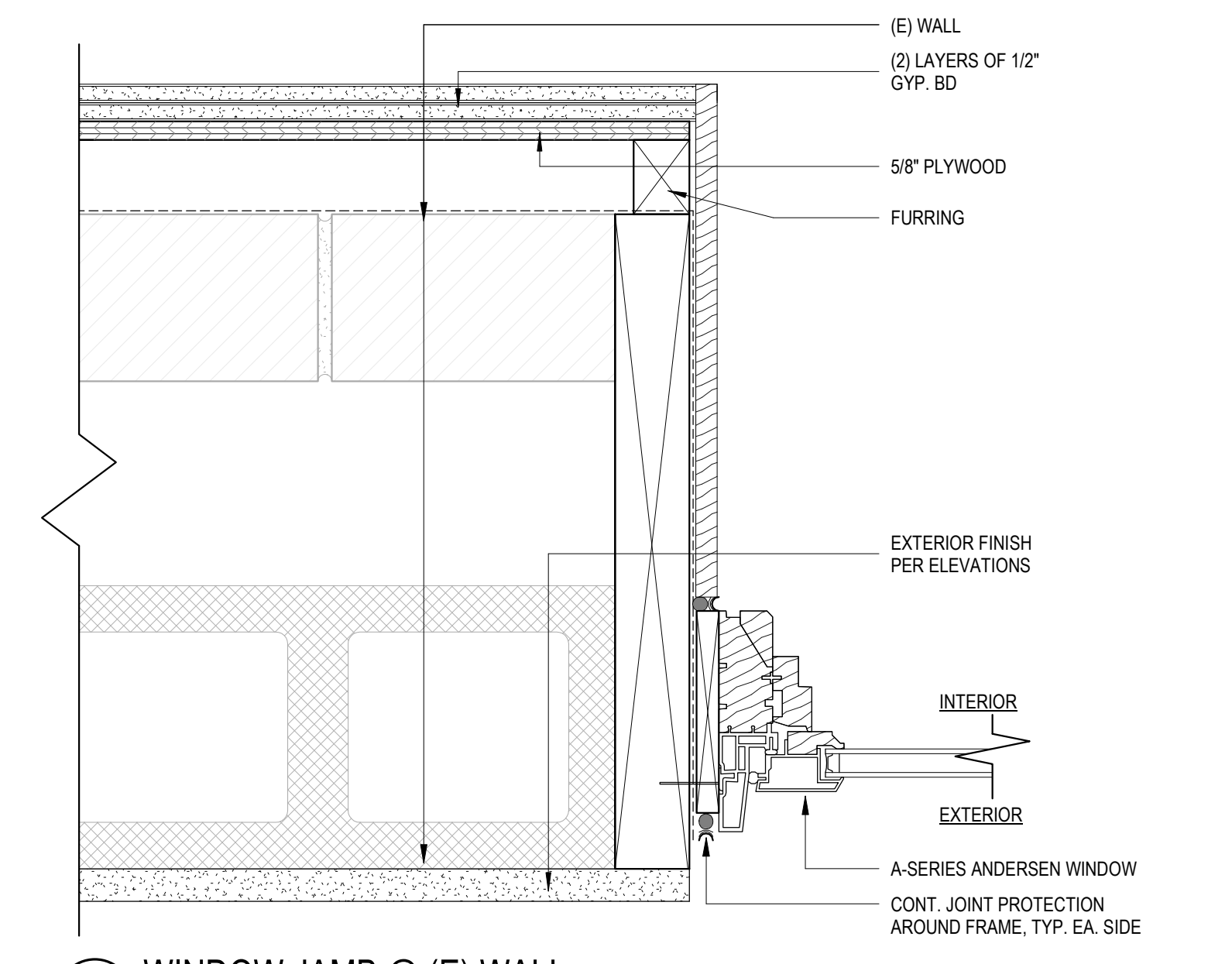

05 WINDOW JAMB @ (E) WALL
3" = 1'-0"

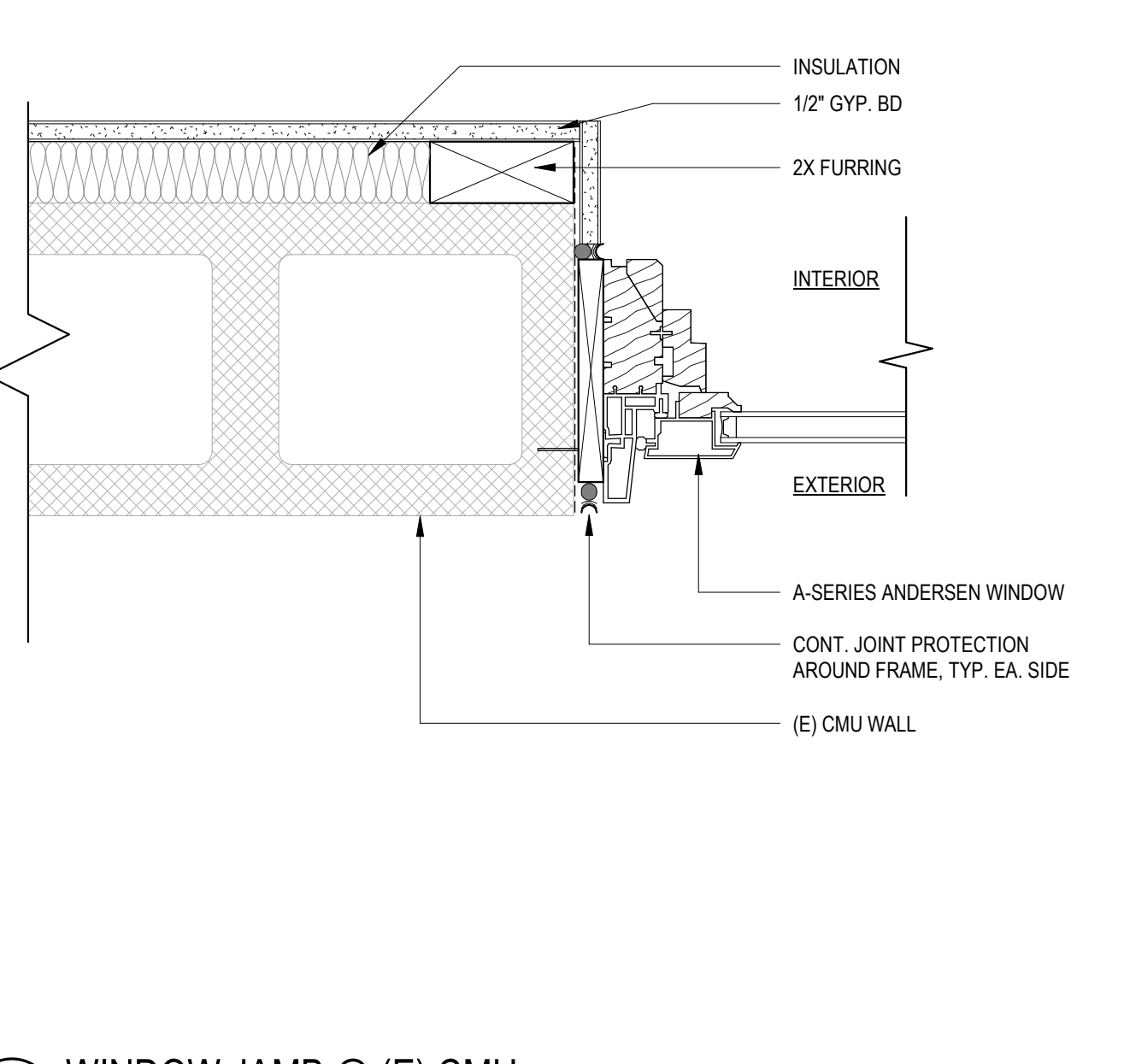

02 WINDOW JAMB @ (E) CMU
3" = 1'-0"

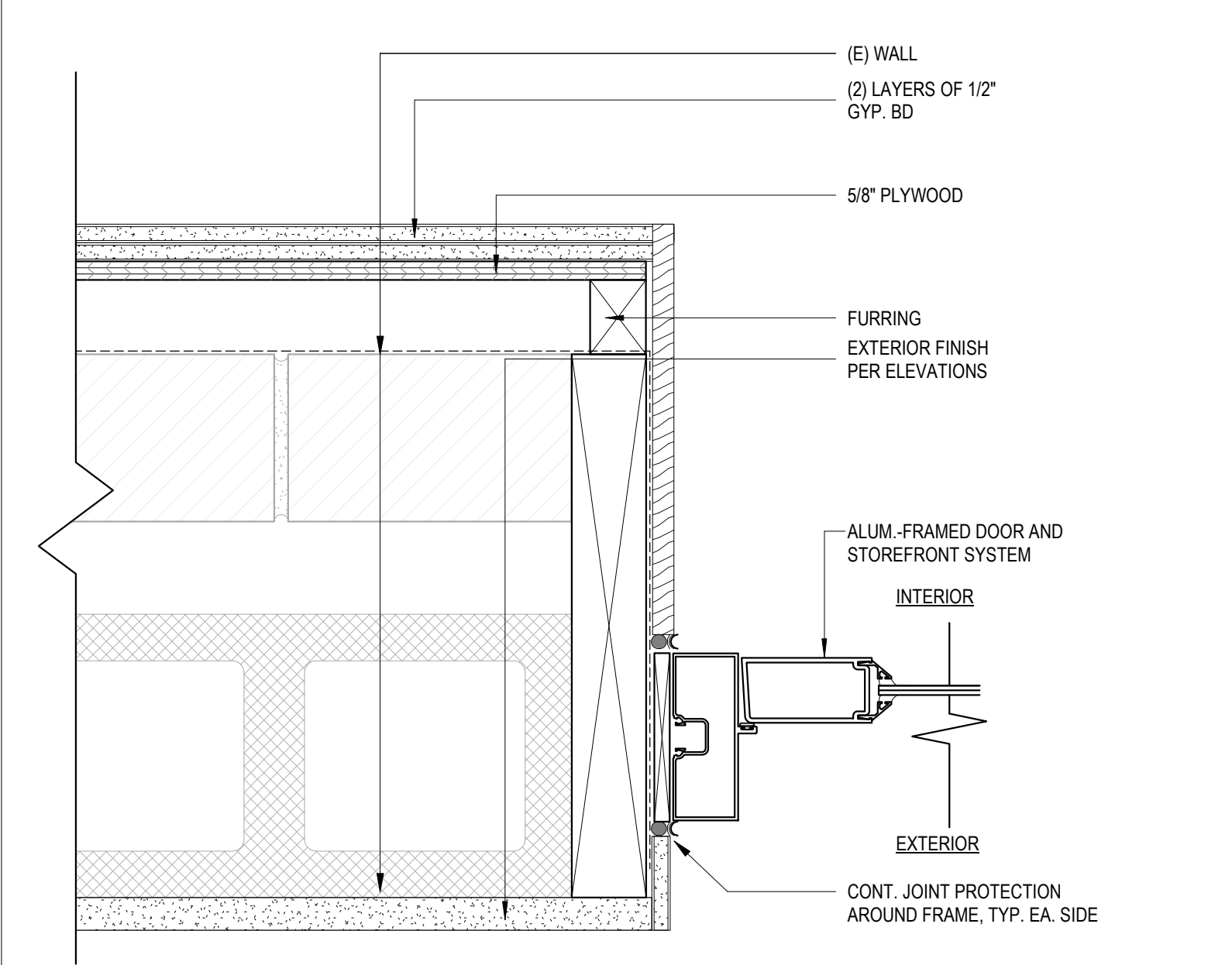

12 STOREFRONT DOOR JAMB @ (E) WALL
3" = 1'-0"

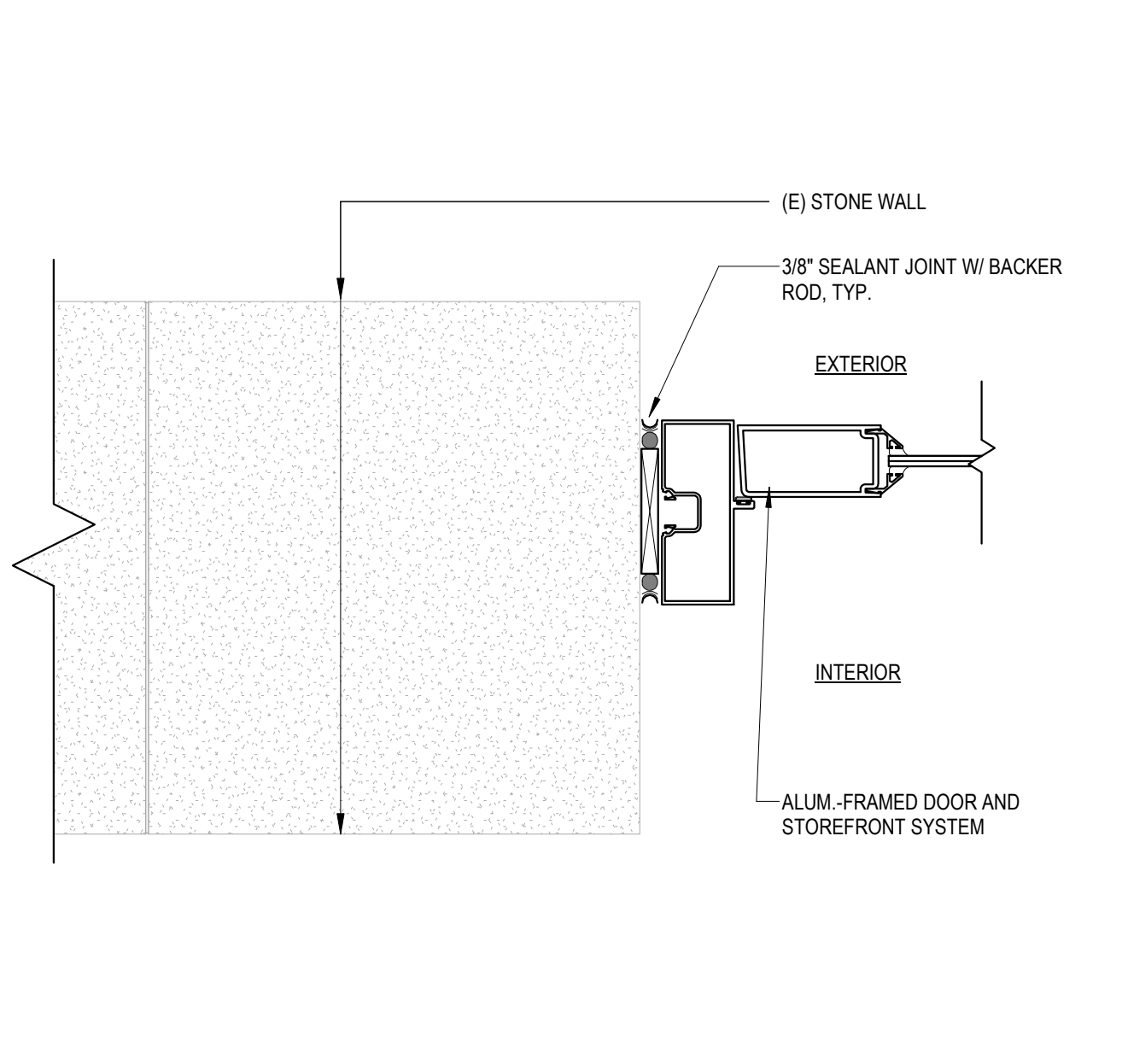

09 STOREFRONT DOOR JAMB @ STONE WALL
3" = 1'-0"

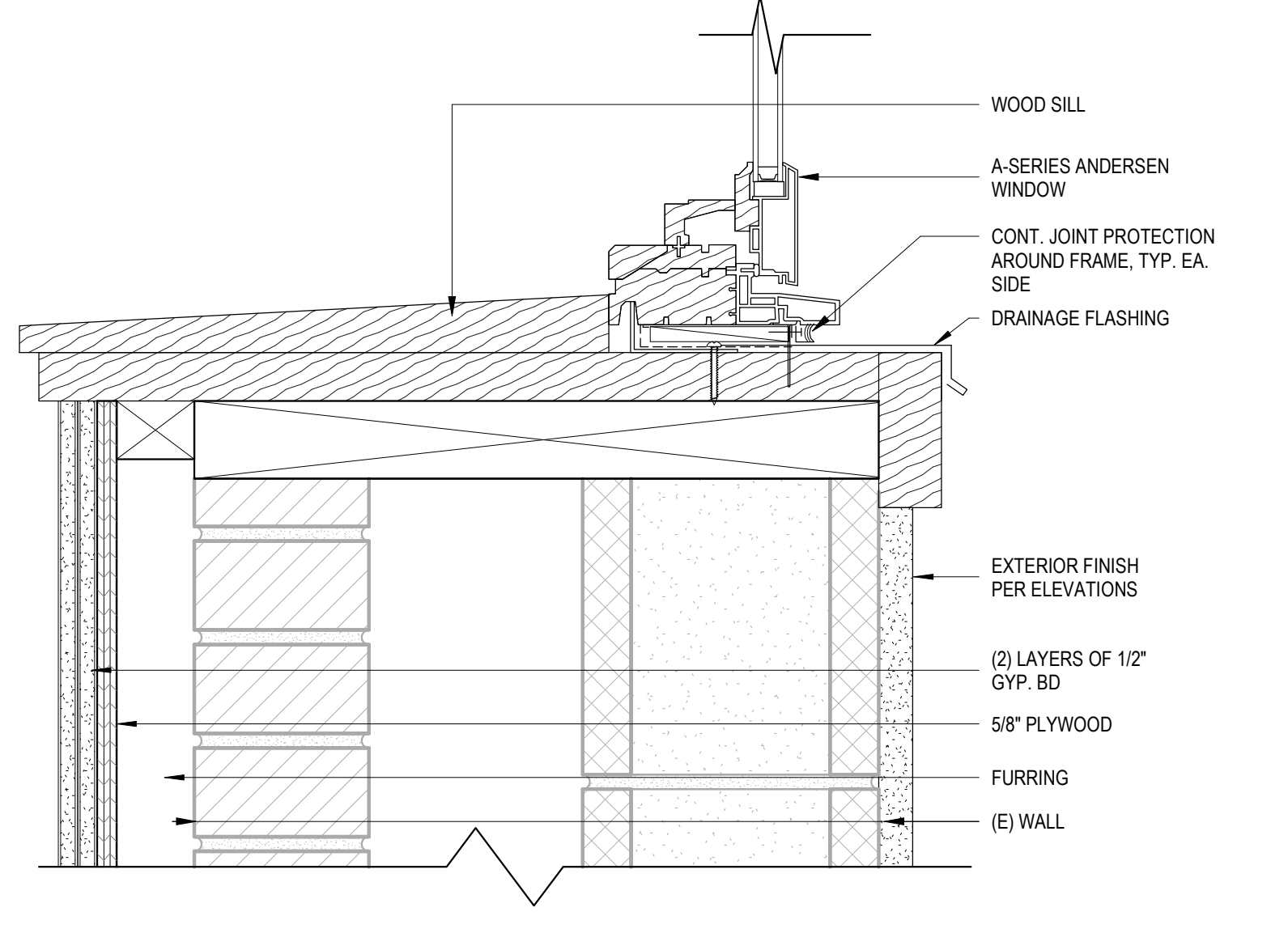

06 WINDOW SILL @ (E) WALL
3" = 1'-0"

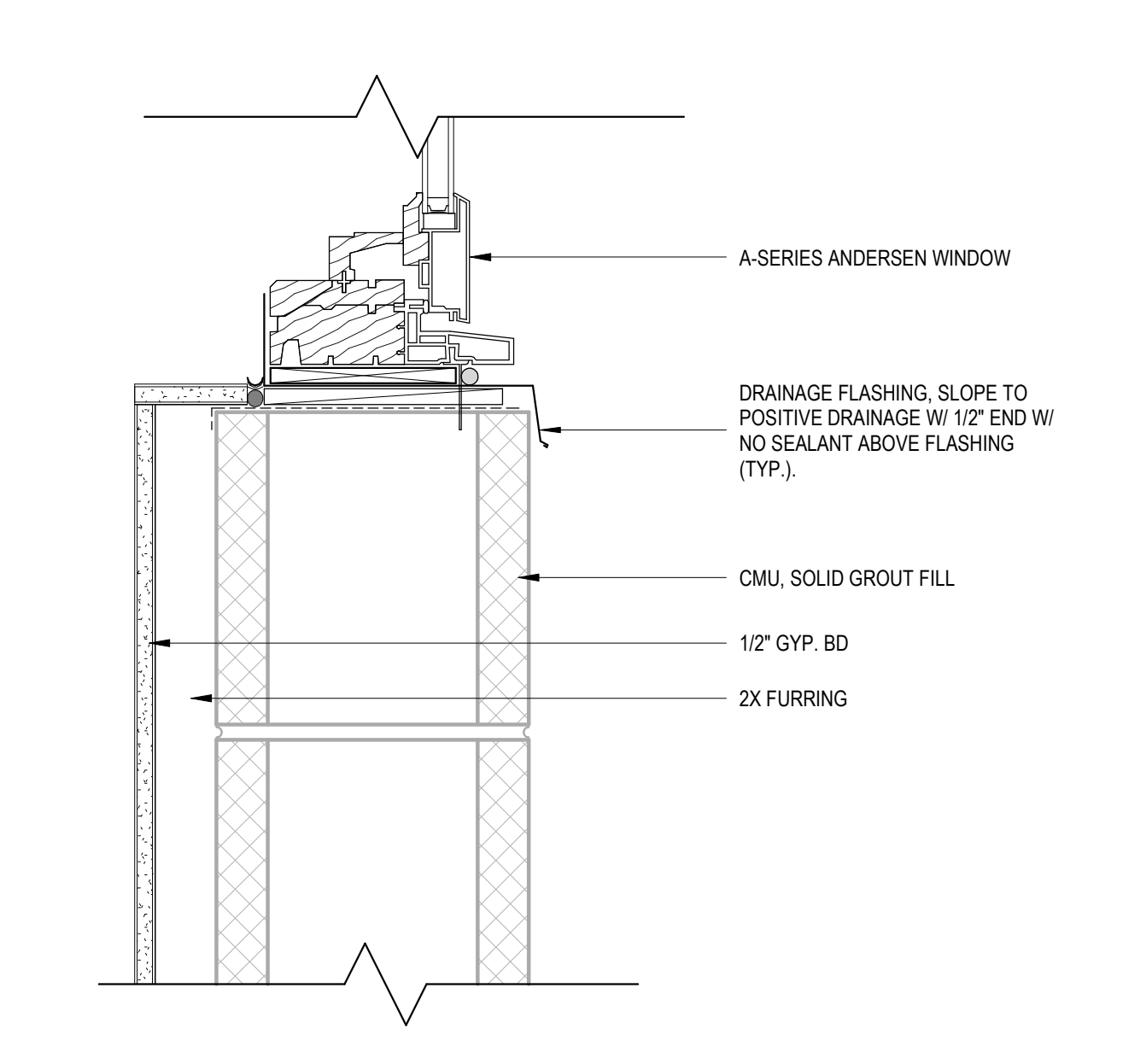

03 WINDOW SILL @ (E) WALL
3" = 1'-0"



12 / 31 / 2024



231 2nd Avenue SW
Albany, Oregon 97321
Ph: 541.497.2954

ARCHITECT
VARTONE ARCHITECTURE, LLC
CHRISTINA LARSON
PH: (541) 497-2954
231 2nd AVE SW
ALBANY, OR 97321
LAND USE PLANNER
UDELL ENGINEERING
LAURA LAROQUE
PH: (541) 451-6125
63 E ASH ST.
LEBANON, OR 97355

ALBANY FEDERAL BUILDING
HISTORIC REVIEW
240 SW 2ND AVE
ALBANY, OR 97321

Issue: HISTORIC REVIEW
Date: 09-04-2024

Revision: Date:

DETAILS

HR-8

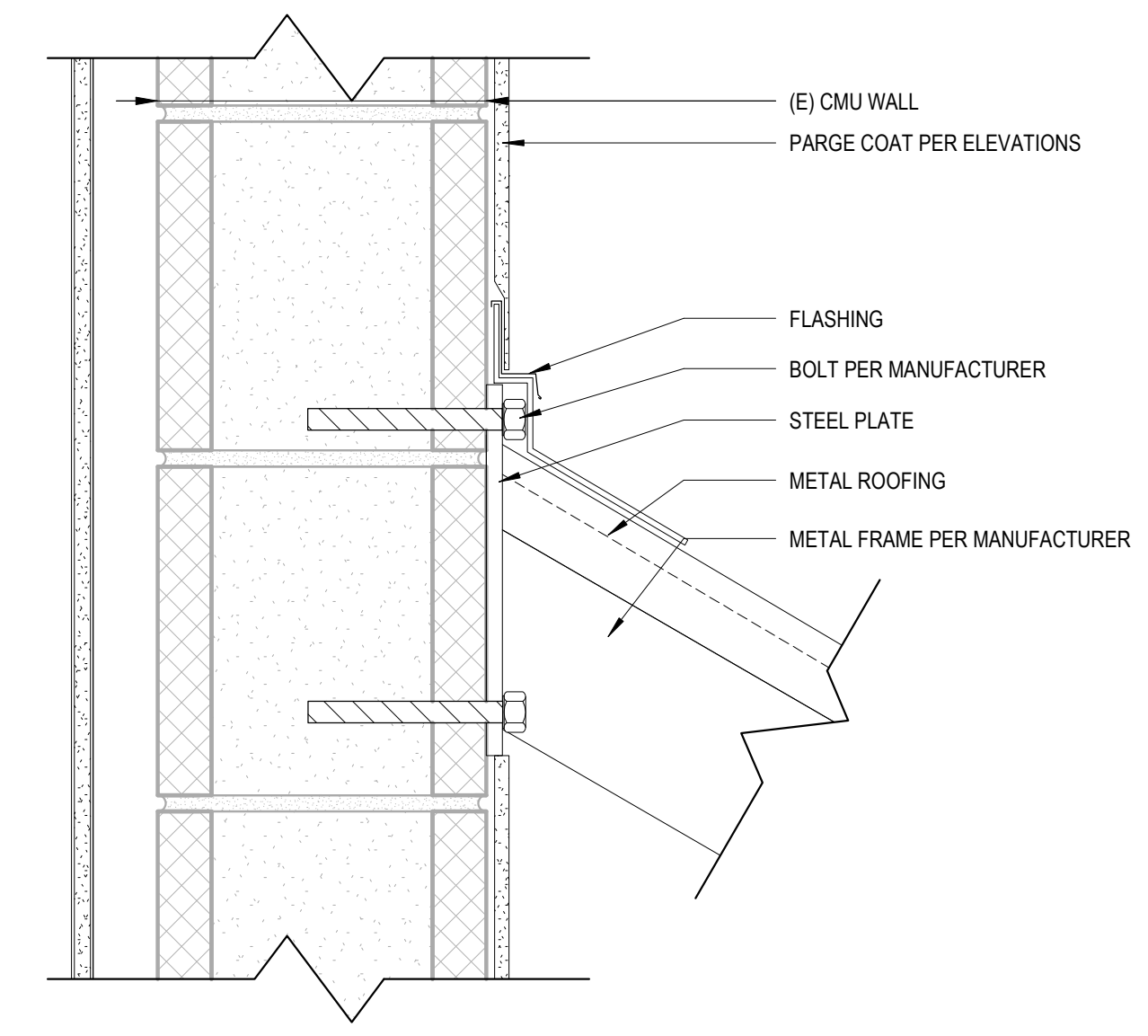

04 ENLARGED CANOPY DETAIL
3" = 1'-0"

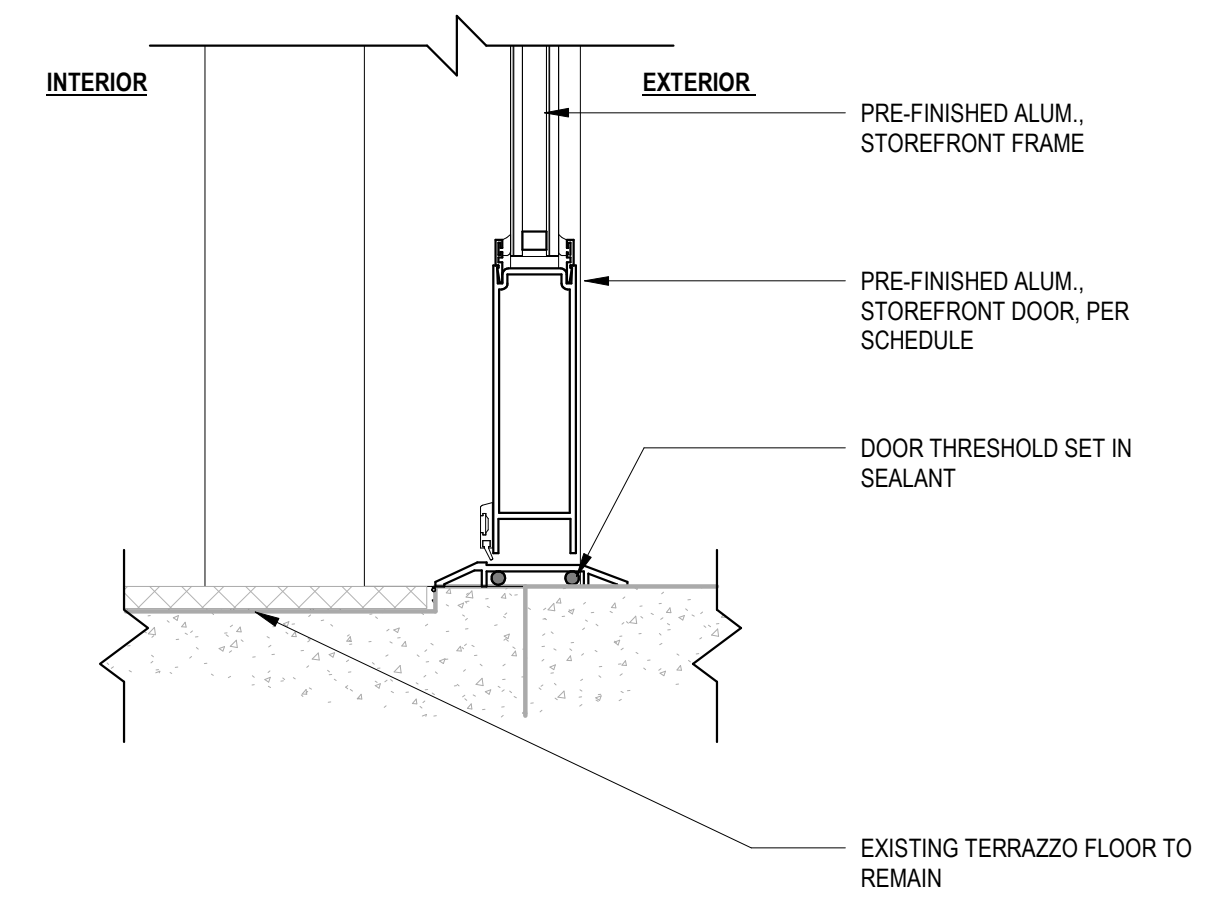

01 ENTRY DOOR THRESHOLD DETAIL
3" = 1'-0"

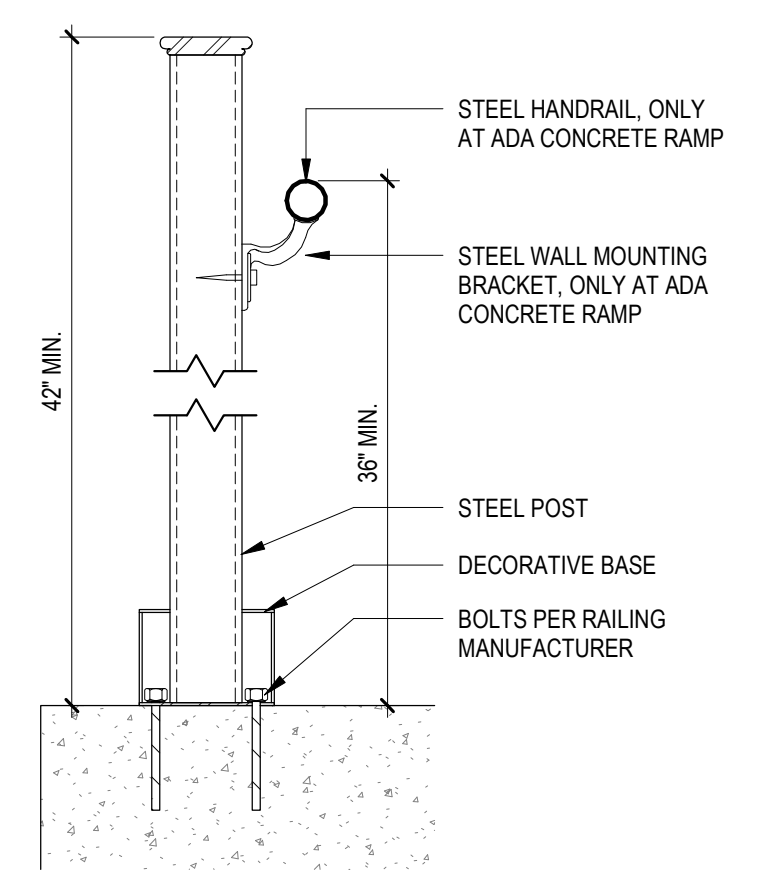

05 RAILING DETAIL
1 1/2" = 1'-0"

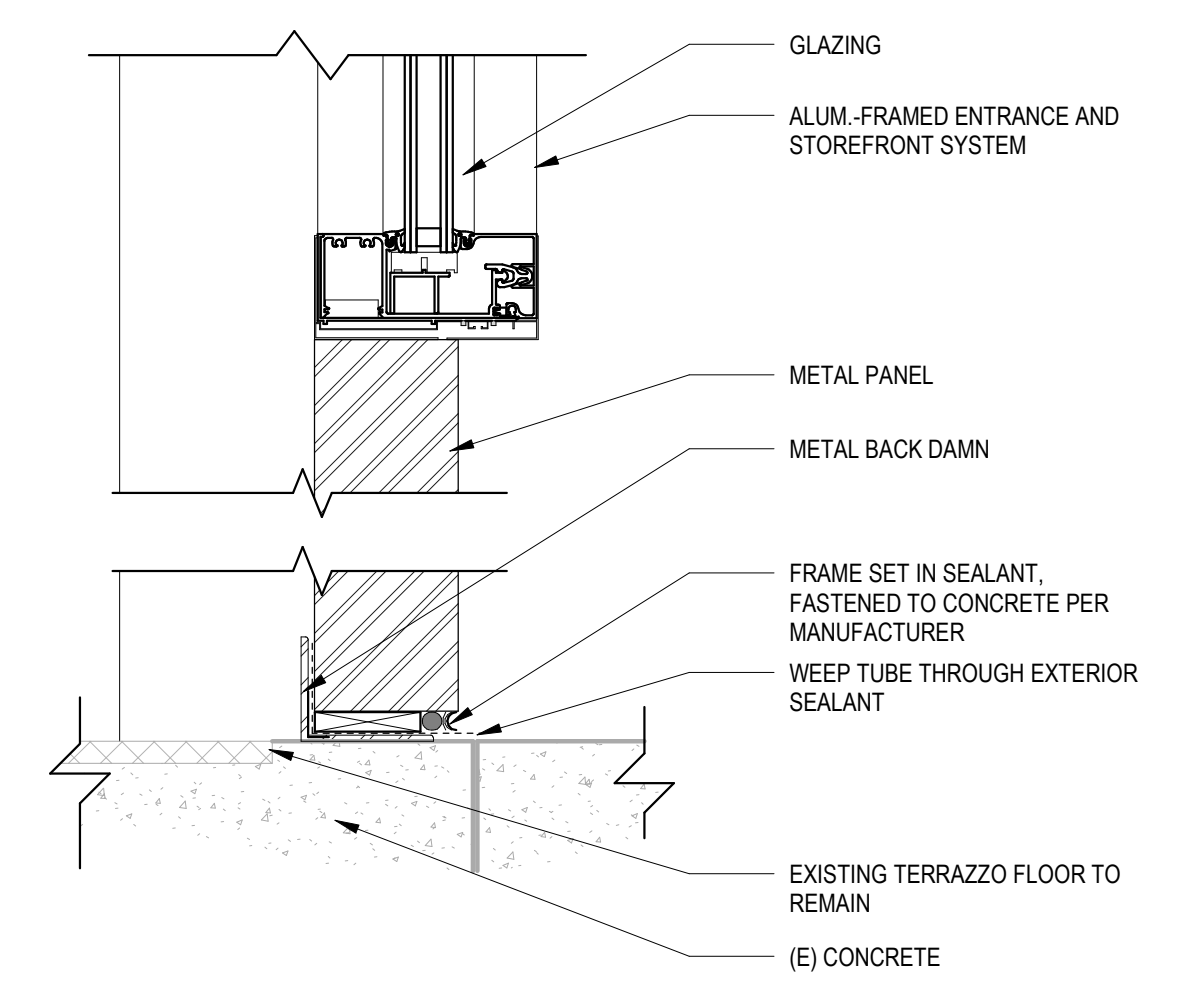

02 STOREFRONT SILL DETAIL
3" = 1'-0"

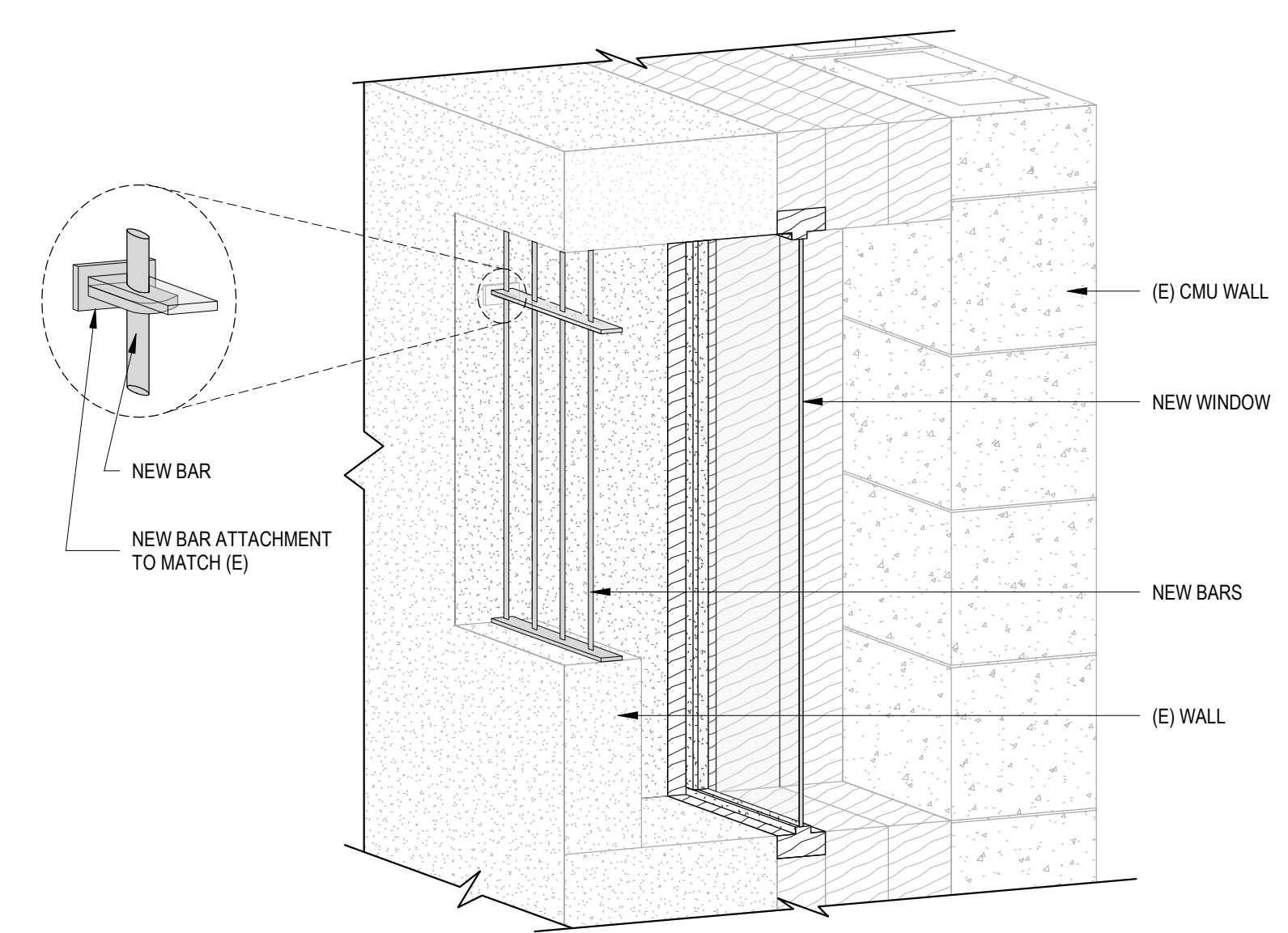

6 3D BAR DETAIL
1 1/2" = 1'-0"

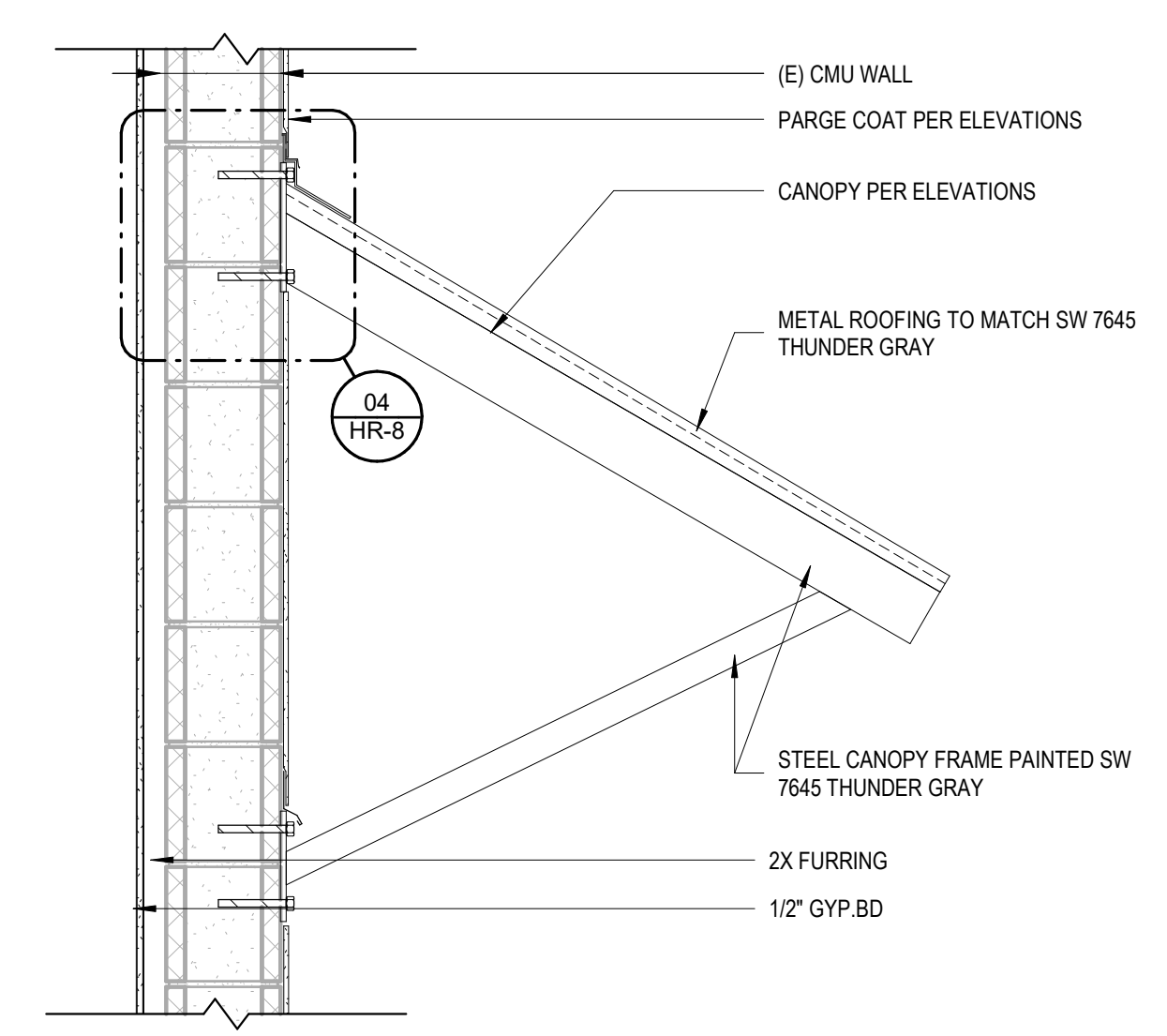

03 CANOPY DETAIL
1" = 1'-0"